

## PLUTO Safety-PLC

### Programming manual

## About this manual

This manual is divided in two parts; part 1 describing how to use the programming tool Pluto Manager and part 2 describing the language rules.

Part 1 begins with the chapter “Making your first program” which leads you through the creation of a simple example. For first time users this can be a good way to get started.

The programming language is related to the programming standard IEC 61131-3. The programming can also be done in text form with a standard text editor. Before downloading to the system the code must be compiled to hex-format. Download of the hex-file to a PLUTO-unit and monitoring is possible by either Pluto Manager or a standard terminal program as Hyper Terminal.

## Table of contents

Part 1 .....	5
1 Safety note .....	5
2 Installation .....	5
3 Making your first program .....	6
3.1 Creating a new project .....	6
3.2 Name and description .....	7
3.3 Include source file .....	7
3.4 Saving .....	8
3.5 Selection of function block library .....	8
3.6 Hardware setup .....	10
3.6.1 Instruction set 2 / instruction set 3 .....	11
3.7 Configuration of I/O .....	12
3.7.1 No Filt .....	12
3.7.2 Disabling of test pulses .....	13
3.8 Example of setup of I/O-options .....	14
3.9 Naming of variables .....	15
3.10 Programming the ladder logic .....	16
3.11 Adding comments and finalising the network .....	22
3.12 Next network .....	23
3.13 Connecting the components .....	25
4 Projects Open, close, save, .....	27
4.1 Password protect .....	28
4.1.1 Opening a password protected file .....	29
5 Bus configuration .....	30
5.1 Identifier IDFIX number .....	31
5.1.1 Read IDFIX number from Pluto .....	31
5.2 Advanced settings .....	32
5.3 External communication .....	32
6 I/O Options .....	33
7 AS-i bus functions .....	34
7.1 Initial configuration of AS-i functions .....	34
7.1.1 “New Pluto”, selection of family and station number .....	34
7.1.2 Working mode on the AS-i bus .....	35
7.1.2.1 Variants of monitor mode: .....	36
7.1.3 Page for AS-i specific setup .....	37
7.1.4 Manual configuration of slave types (profiles) .....	38
7.1.4.1 Undefined .....	38
7.1.4.2 Safe input .....	39
7.1.4.3 Nonsafe Standard slaves .....	41

7.1.4.4	Nonsafe A/B slaves .....	41
7.1.4.5	Combined Transaction A/B slaves.....	41
7.1.4.6	Analogue input slaves .....	41
7.1.4.7	Analogue output slaves (non-safe) .....	42
7.1.4.8	Safe Output .....	42
7.1.4.9	Pluto as Safe Input .....	43
7.1.5	Write parameter to slave and receive info back .....	43
7.2	Online configuration of AS-i bus .....	44
7.2.1	Read AS-i slaves .....	44
7.2.1.1	Configuration in Monitor mode.....	45
7.2.2	Teach safety codes .....	46
7.2.2.1	Set slave output.....	47
7.3	Other online tools .....	47
7.3.1	AS-i status.....	48
7.3.2	Show code table.....	50
7.3.3	Teach code table.....	50
7.3.4	Erase code table .....	50
7.3.5	Change address on a slave .....	51
8	StatusBus.....	52
8.1	Teach addresses .....	53
8.2	Status.....	54
8.3	Change slave address.....	55
8.4	Exchange of slave/Automatic addressing .....	55
8.5	StatusBus – Function blocks .....	56
9	Analogue inputs Pluto D20 and D45 – Function blocks .....	58
9.1	Application example with two sensors – Temperature measurement.....	60
10	Counter inputs Pluto D45.....	61
10.1	Application with two encoders – Speed monitoring.....	63
10.2	Application with one encoder and one analogue value – Speed monitoring.....	64
11	Variables .....	66
11.1.1	Symbolic Name .....	66
11.1.2	Description .....	66
11.2	Local/Global variables .....	66
11.2.1	Export variables.....	69
11.3	Remanent variables.....	71
11.3.1	Clear Remanent variables .....	72
11.4	Export and import variable names .....	73
12	Ladder logic programming.....	74
12.1	Edit mode .....	75
12.2	Tool bar.....	76
12.3	Update / Undo .....	78
12.4	Expand / Collapse networks .....	78
12.5	Drag-and-drop .....	79
12.6	Options.....	81
12.7	Sequences .....	83
13	Project setup .....	84
13.1	Function libraries .....	84
13.2	Merge projects.....	85
14	Compilation .....	86
15	General Preferences .....	87
16	Online operations .....	90
16.1	Communication .....	90
16.2	Tools menu.....	90
16.2.1	Erase PLC Program / Change of password.....	90
16.2.2	Online info .....	90

16.2.3	Copy online IDFIX to Clipboard .....	90
16.2.4	Terminal window .....	91
16.2.5	Reset all Plutos .....	91
16.2.6	Write IDFIX.....	92
16.2.7	Upload Program from Pluto .....	92
16.2.8	Pluto System Software (Updating the Operating System files in Pluto).....	94
16.3	Program download .....	96
16.4	Insertion of Pluto unit in existing project afterwards .....	97
16.5	Change of baud rate, error code Er26 .....	97
16.6	Online.....	98
16.7	Seal.....	101
17	Remote monitoring via Pluto Ethernet Gateway .....	102
17.1	Configuring the gateway for remote monitoring .....	102
17.2	Remote monitoring .....	102
18	Create function block libraries .....	105
18.1	Sequences in function blocks .....	109
18.2	Compiler directives.....	110
18.3	Other new functions.....	112
Part 2.....		113
1	Bit-instructions.....	113
1.1	Addressing of bit-operands.....	113
1.2	Register bits (Instruction set 3 only).....	115
1.3	Boolean instructions .....	116
1.4	Edge detection .....	118
1.4.1	Inverted edge detection (Instruction set 3 only) .....	118
1.5	Latch function .....	119
1.6	Toggle function.....	120
1.7	Timers .....	121
2	Memories .....	123
2.1	Local memories (M).....	123
2.2	Global memories (GM) .....	123
2.3	System memories (SM) .....	124
3	Sequences .....	125
3.1	Addressing .....	125
3.2	Jump .....	126
4	Numeric operations .....	128
4.1	Registers.....	128
4.1.1	Addressing .....	128
4.1.1.1	Half Double Registers.....	128
4.1.2	Operations.....	129
4.1.3	System registers.....	133
4.2	Use of analogue values .....	135
5	Program declaration in text form.....	137
5.1	Identity, station number and Pluto family .....	137
5.2	Declaration of program code .....	137
5.3	Declaration of I/O .....	138
5.4	Symbolic names .....	139
6	Program example in text form.....	140
7	Appendix A, Compatibility for Pluto.....	141

# Part 1

## Pluto Manager

### 1 Safety note

Note that logic faults, like for example an emergency stop that controls the wrong output, cannot be detected by this software tool. Programs must therefore be reviewed and the safety applications carefully tested before being used in applications.

### 2 Installation

Installation of Pluto Manager is performed by executing the self extracting EXE-file (InstallPlutoManager... .exe) without any parameters. This leads the user through the installation allowing the user to select the appropriate location.

To run the program a registration code is required. However it is possible to use it without code in DEMO mode where compilation and online functions are disabled.

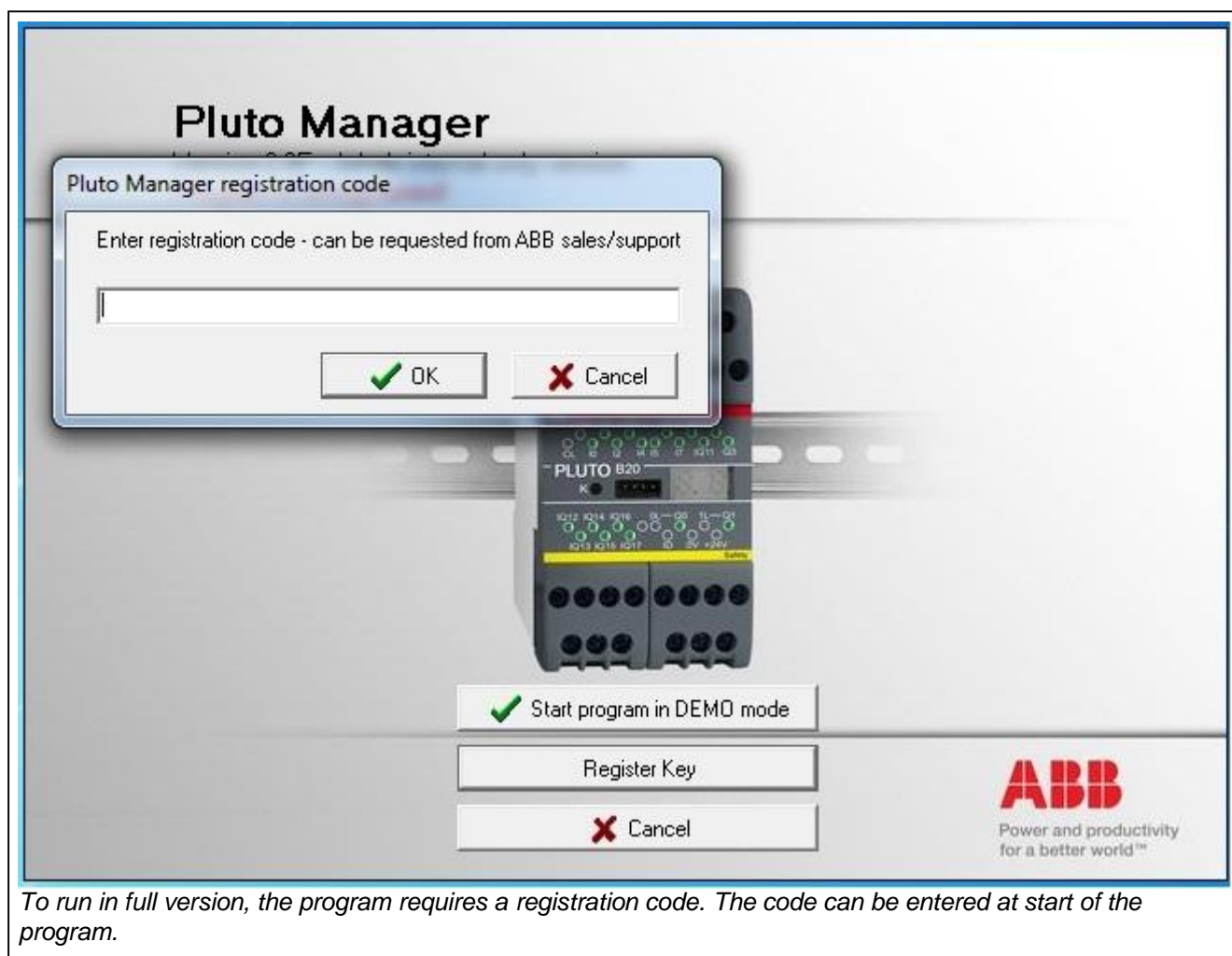

*To run in full version, the program requires a registration code. The code can be entered at start of the program.*

### 3 Making your first program

The quickest way to introduce yourself to the Pluto Manager is to write an application. This tutorial guides you through the creation of a Pluto program.

#### 3.1 Creating a new project

After opening Pluto Manager a new project can be created by choosing “New” / “Project” under the “File” menu. If an existing program is to be loaded, select “Open”.

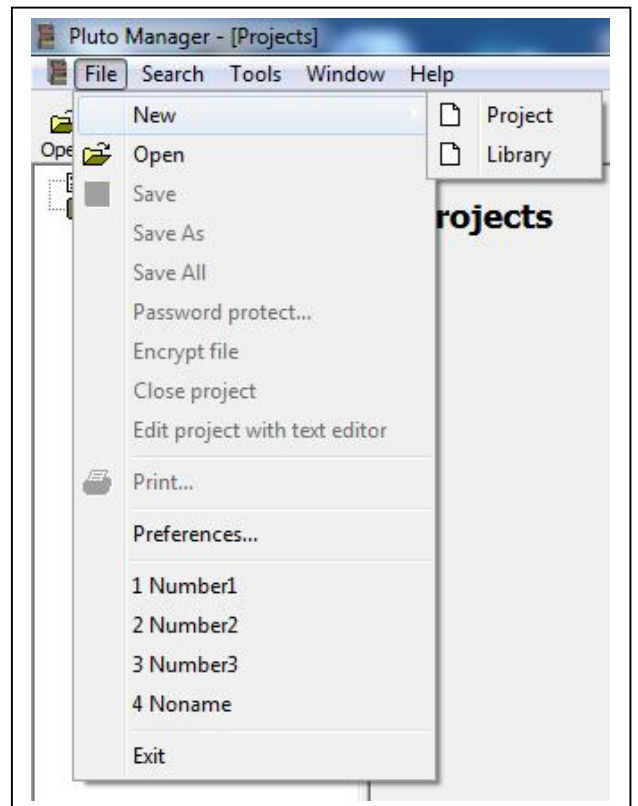

### 3.2 Name and description

An initial page with fields for “Project Name” and “Project Description” is shown.

“Project Name” is later downloaded to the Pluto units and when going online it is checked. <FILENAME> is default and will be substituted with the program file name.

“Project Description” is just for making your own notes.

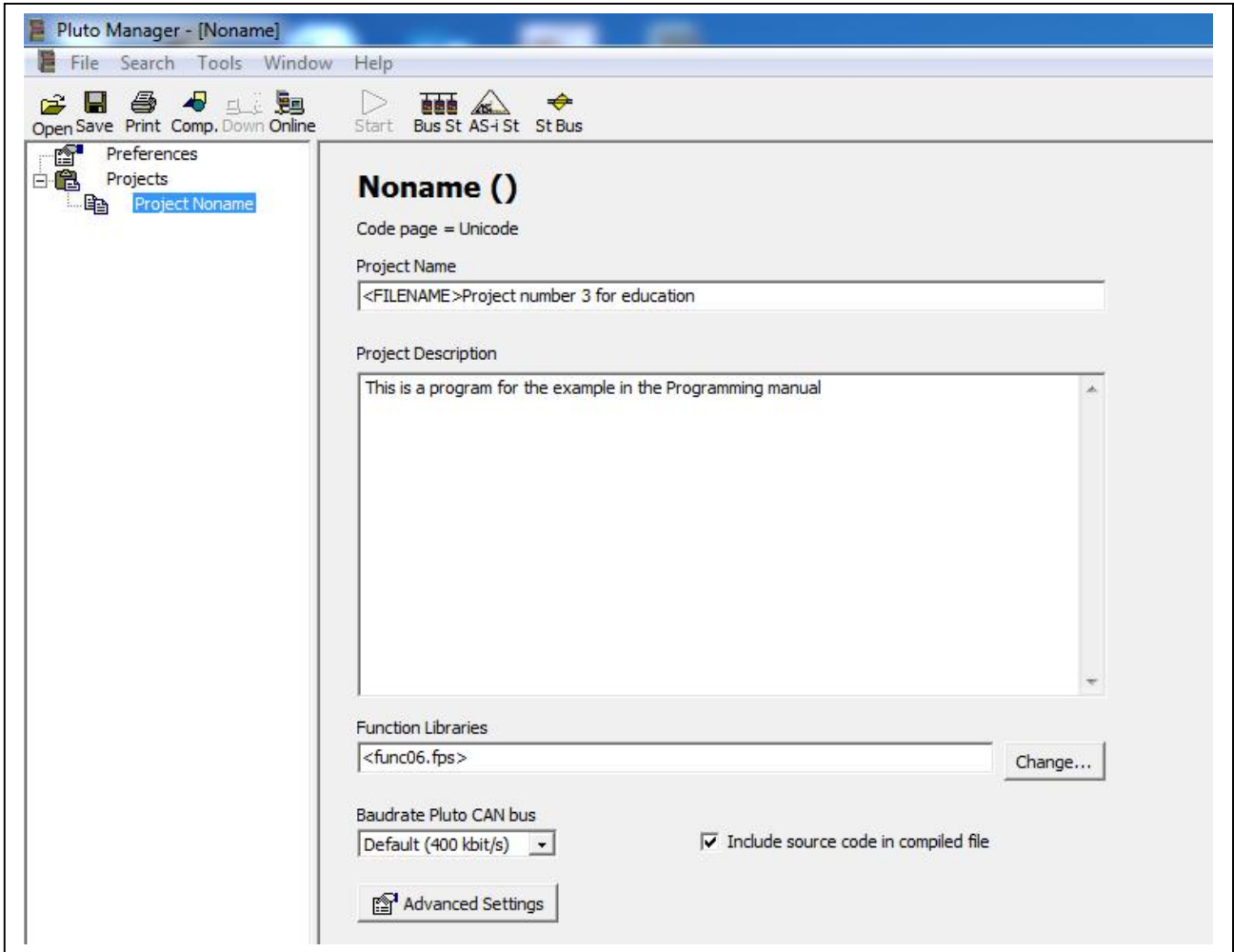

### 3.3 Include source file

If the check box "Include source code in compiled file" is checked, the PLC source code will be included in the file downloaded to Pluto. The advantage with this is that the source file is always accessible if the PLC program is uploaded from Pluto. The disadvantages are that the file size will be increased (if the program already is large this may be a problem), and that anybody with access to a PC and the password will be able to alter the PLC program.

### 3.4 Saving

At this stage it can be a good idea to save for the first time. The toolbar provides quick mouse access to save. When the project is not saved before, Pluto Manager displays the Save As dialog box. “Save” and “Save As” can also be found under the File menu. The source file is automatically saved with file extension .sps if nothing else is specified.

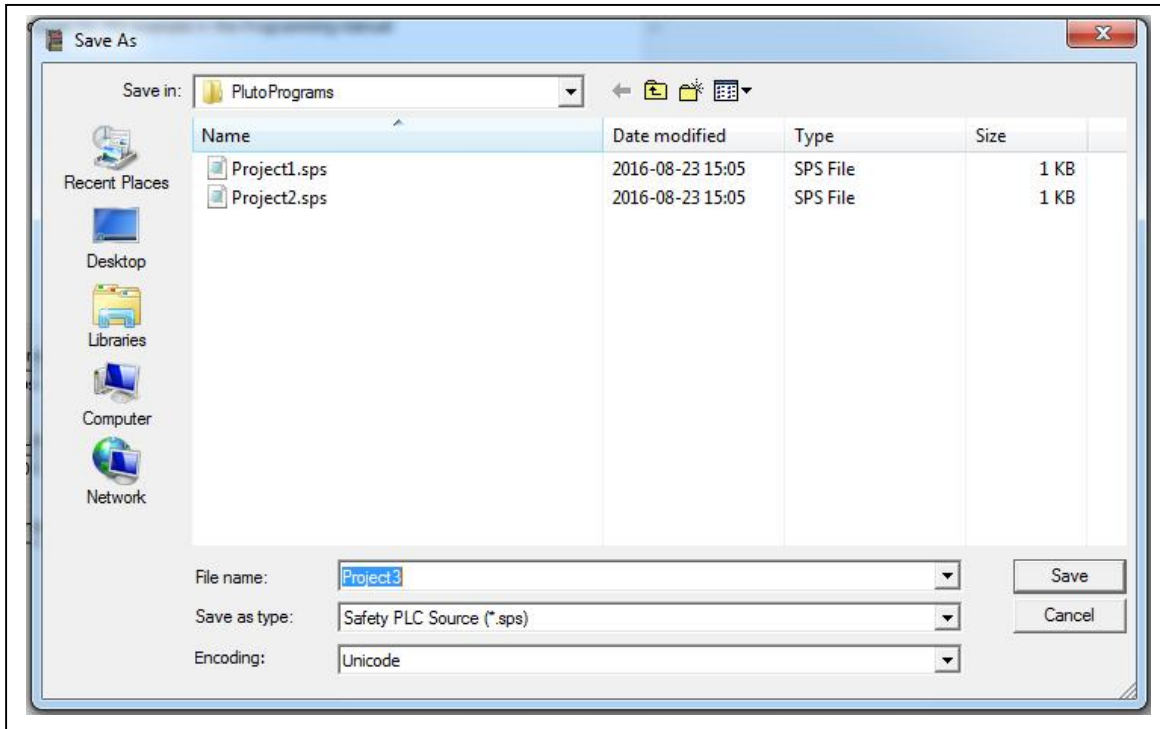

### 3.5 Selection of function block library

The Pluto system offers the possibility for using pre-programmed function blocks/macros for different safety functions and safety devices. These function blocks are stored in separate library files. Standard libraries are included in Pluto Manager but it is also possible to make user specific libraries.

Select “Function library”, “Change”, and then “Add standard Library”. A list with available libraries is shown.

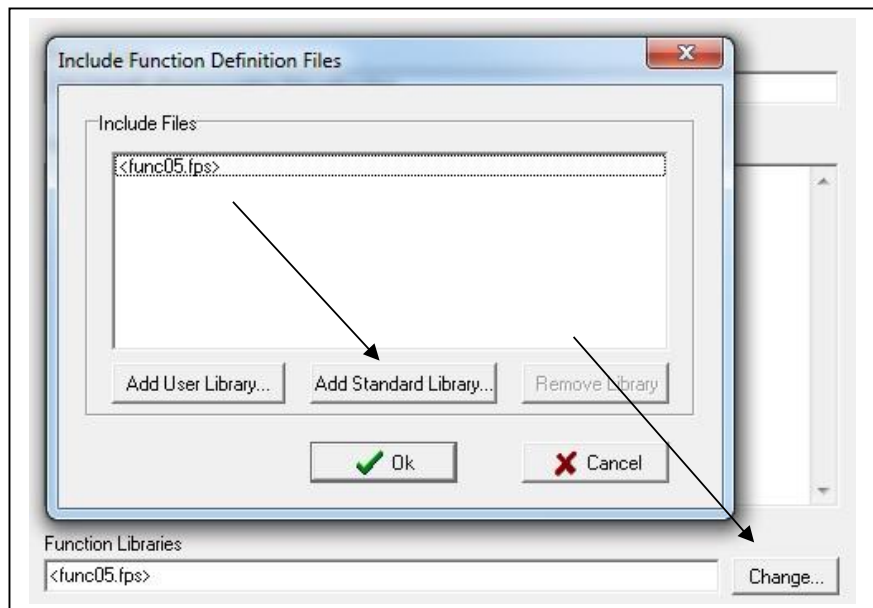



By “Add standard Library” Pluto Manager looks for the files at “..\PlutoManager\Library” where they normally are stored by the installation program. If “Add User Library” is selected, Pluto Manager looks for the files in the directory where the project files are stored.

### 3.6 Hardware setup

Next step is setting up the project according to the installed hardware.

Go to the tree menu to the left and make a right mouse click on the project name. Select “New Pluto” when the new dialog is opened.

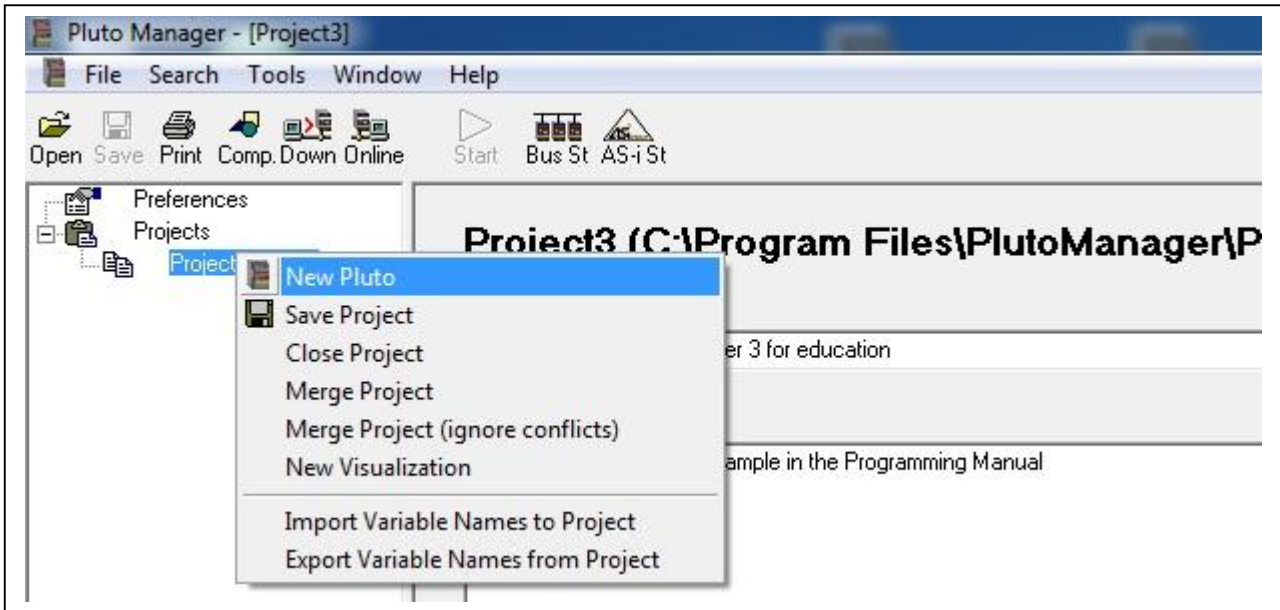

A dialog box for entering Pluto type and station number appears. The station number can be anything between 0...31.

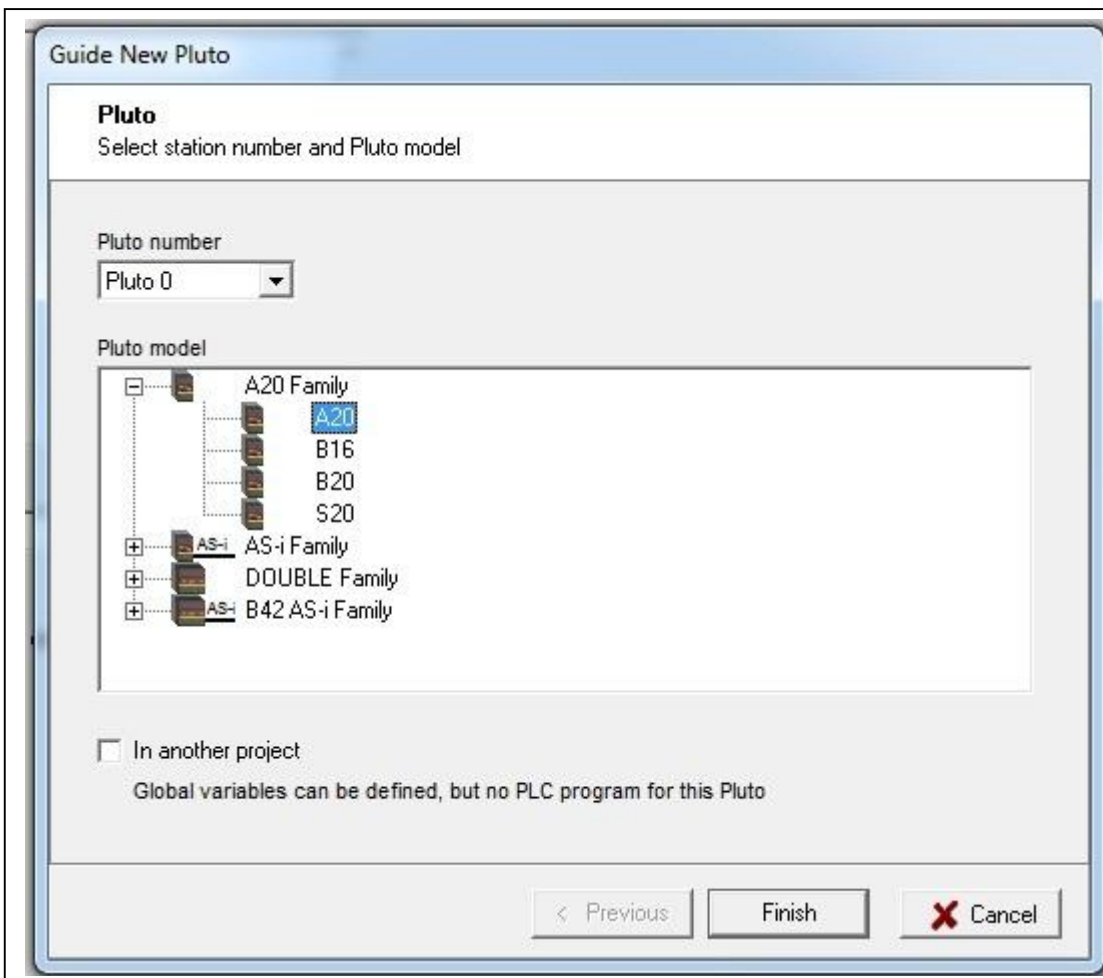

### 3.6.1 Instruction set 2 / instruction set 3

When Pluto type is selected the question about “instruction set 2” or “instruction set 3” appears. “Instruction set 3” is only compatible with Pluto OS version 3.0 or higher, and implies a number of new instructions such as Off delayed timer, multiplication and division between registers and constants, double registers (32 bits), “Not positive edge” and “Not negative edge” detection, possibility to address individual register bits and extended address range. All of this is described in Part 2 of this manual.

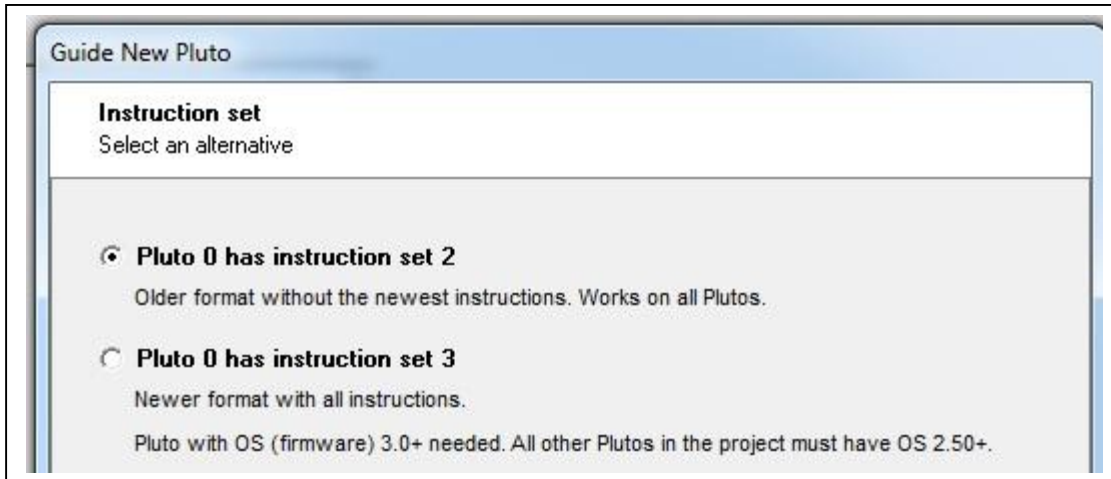

When the station number, Pluto type and “instruction set 2” / “instruction set 3” has been selected the tree is expanded with a Pluto unit symbol and on a level below “I/O options”, “Variables” and “PLC Code” each representing a window.

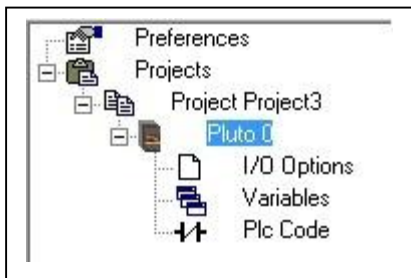

### 3.7 Configuration of I/O

Since the I/Os can be used in different ways, a configuration must be performed. This configuration must reflect the hardware design.

The “I/O Option” window, lists the terminals I0...I7 and IQ10...IQ17. The safety outputs Q0...Q3 are not listed since they can only be used in one way.

Signal	Type of signal	Shape/Level	Options	
I0.0	Undefined		<input type="checkbox"/> Non_Inv	<input type="checkbox"/> No_Filt
I0.1	Undefined		<input type="checkbox"/> Non_Inv	<input type="checkbox"/> No_Filt
I0.2	Undefined		<input type="checkbox"/> Non_Inv	<input type="checkbox"/> No_Filt
I0.3	Undefined		<input type="checkbox"/> Non_Inv	<input type="checkbox"/> No_Filt
I0.4	Undefined		<input type="checkbox"/> Non_Inv	<input type="checkbox"/> No_Filt
I0.5	Undefined		<input type="checkbox"/> Non_Inv	<input type="checkbox"/> No_Filt
I0.6	Undefined		<input type="checkbox"/> Non_Inv	<input type="checkbox"/> No_Filt
I0.7	Undefined		<input type="checkbox"/> Non_Inv	<input type="checkbox"/> No_Filt

Signal	Type of signal	Shape/Level	Options	
IQ0.10	Undefined		<input type="checkbox"/> Non_Inv	<input type="checkbox"/> No_Filt
IQ0.11	Undefined		<input type="checkbox"/> Non_Inv	<input type="checkbox"/> No_Filt
IQ0.12	Undefined		<input type="checkbox"/> Non_Inv	<input type="checkbox"/> No_Filt
IQ0.13	Undefined		<input type="checkbox"/> Non_Inv	<input type="checkbox"/> No_Filt
IQ0.14	Undefined		<input type="checkbox"/> Non_Inv	<input type="checkbox"/> No_Filt
IQ0.15	Undefined		<input type="checkbox"/> Non_Inv	<input type="checkbox"/> No_Filt
IQ0.16	Undefined		<input type="checkbox"/> Non_Inv	<input type="checkbox"/> No_Filt
IQ0.17	Undefined		<input type="checkbox"/> Non_Inv	<input type="checkbox"/> No_Filt

The preferred setting is selected via drop down lists.

Signal	Type of signal	Shape/Level	Options	
I0.0	Input	Static	<input type="checkbox"/> Non_Inv	<input type="checkbox"/> No_Filt
I0.1	Undefined	A_Pulse	<input type="checkbox"/> Non_Inv	<input type="checkbox"/> No_Filt
I0.2	Undefined	B_Pulse	<input type="checkbox"/> Non_Inv	<input type="checkbox"/> No_Filt
I0.3	Undefined	C_Pulse	<input type="checkbox"/> Non_Inv	<input type="checkbox"/> No_Filt
I0.4	Undefined	Static	<input type="checkbox"/> Non_Inv	<input type="checkbox"/> No_Filt

#### 3.7.1 No Filt

If the checkbox “No\_Filt” is crossed the response time is decreased by 5 ms, but the disturbance immunity will be affected negatively.

### 3.7.2 Disabling of test pulses

The test pulses for the outputs Q2 and Q3 (described in Pluto Hardware Manual) can sometimes lead to problems together with some connected equipment. For instance can connection of some modern contactors with high capacitance cause Er40 in Pluto.

For this reason Pluto A20 v2, B20 v2, S20 v2 and Pluto D20 offers a possibility to disable these test pulses. However, if they are disabled Pluto will not be able to detect a short circuit between Q2 and Q3 or between Q2/Q3 of another Pluto unit.



The screenshot shows the Pluto Manager software interface. On the left, a tree view displays the project structure: Preferences, Projects, Project D20\_Example, Pluto 0, I/O Options (highlighted), Variables, and Plc Code. On the right, a panel titled 'Failsafe outputs' contains a table with two rows:

Signal	Options
Q0.2	<input checked="" type="checkbox"/> No_Test_Pulse
Q0.3	<input type="checkbox"/> No_Test_Pulse

*In Pluto Manager, on the I/O Options page, the test pulses for Q2/Q3 can be disabled.*

### 3.8 Example of setup of I/O-options

The pictures below show first an example of wiring, and then the corresponding configuration in the "I/O Option" window.

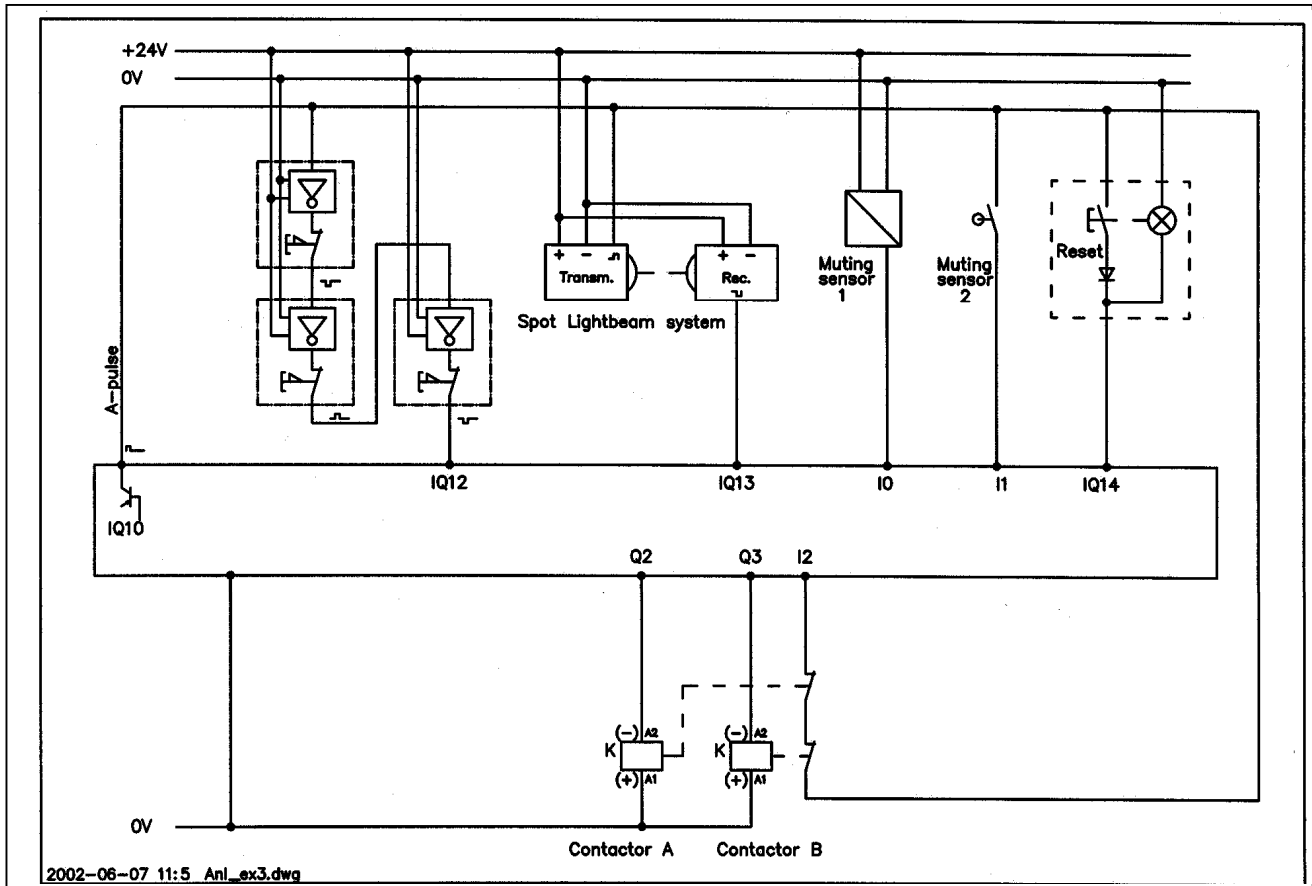

**Note:** The configuration of I/O is dependent on the hardware design. The correct use of inputs, outputs, dynamic signals etc. which is safety related, is normally the hardware designer's responsibility.

Failsafe inputs			
Signal	Type of signal	Shape/Level	Options
IO.0	Input	Static	<input type="checkbox"/> Non_Inv <input type="checkbox"/> No_Filt
IO.1	Input	A_Pulse	<input checked="" type="checkbox"/> Non_Inv <input type="checkbox"/> No_Filt
IO.2	Input	A_Pulse	<input checked="" type="checkbox"/> Non_Inv <input type="checkbox"/> No_Filt
IO.3	Undefined		<input type="checkbox"/> Non_Inv <input type="checkbox"/> No_Filt
IO.4	Undefined		<input type="checkbox"/> Non_Inv <input type="checkbox"/> No_Filt
IO.5	Undefined		<input type="checkbox"/> Non_Inv <input type="checkbox"/> No_Filt
IO.6	Undefined		<input type="checkbox"/> Non_Inv <input type="checkbox"/> No_Filt
IO.7	Undefined		<input type="checkbox"/> Non_Inv <input type="checkbox"/> No_Filt

Failsafe inputs / Non failsafe outputs			
Signal	Type of signal	Shape/Level	Options
IQ0.10	Output	A_Pulse	<input type="checkbox"/> Non_Inv <input type="checkbox"/> No_Filt
IQ0.11	Undefined		<input type="checkbox"/> Non_Inv <input type="checkbox"/> No_Filt
IQ0.12	Input	A_Pulse	<input type="checkbox"/> Non_Inv <input type="checkbox"/> No_Filt
IQ0.13	Input	A_Pulse	<input type="checkbox"/> Non_Inv <input type="checkbox"/> No_Filt
IQ0.14	Light button	A_Pulse	<input type="checkbox"/> Non_Inv <input type="checkbox"/> No_Filt
IQ0.15	Undefined		<input type="checkbox"/> Non_Inv <input type="checkbox"/> No_Filt
IQ0.16	Undefined		<input type="checkbox"/> Non_Inv <input type="checkbox"/> No_Filt
IQ0.17	Undefined		<input type="checkbox"/> Non_Inv <input type="checkbox"/> No_Filt

### 3.9 Naming of variables

Open the window “Variables” by a left mouse click on the corresponding bus symbol in the tree in the left field. All variables, inputs, outputs, memories, registers etc., can be given a name which further on, when programming the ladder logic, can be used instead of the real I/O name. The naming can be left out or can be done afterwards. (Allowed characters for symbolic names, see 11.1.1 Symbolic name.)

In the field “Description” an explanation of the variable can be made.

Variable attributes: **[G]** Global variable. These variables are visible to other Plutos on the bus.

Safety Inputs | Safety Outputs | NonSafety Outputs | Global Memories | Memories | Registers | Double Registers | System Memories | System F

Status	Variable	Symbolic Name	Description
	I0.0	[G] MuteSensor1	Sensor for initiation of muting. MuteSensor1 and MuteSensor2 is a dual channel
	I0.1	[G] MuteSensor2	Sensor for initiation of muting. MuteSensor1 and MuteSensor2 is a dual channel
	I0.2	[G] ContMonitor	NC contacts of contactors for monitoring
	I0.3	[G]	
	I0.4	[G]	
	I0.5	[G]	
	I0.6	[G]	
	I0.7	[G]	
	I0.10	[G]	
	I0.11	[G]	
	I0.12	[G] EStopButton	Emergency stop buttons
	I0.13	[G] LightBeamSensor	Light beam sensor. Jokab Safety type Spot
	I0.14	[G] ResetButton	Push button for reset of light beam
	I0.15	[G]	
	I0.16	[G]	
	I0.17	[G]	

*Names and descriptions for inputs in Pluto 0.*

Variable attributes: **[G]** Global variable. These variables are visible to other Plutos on the bus.

Safety Inputs | Safety Outputs | NonSafety Outputs | Global Memories | Memories | Registers | Double Registers

Status	Variable	Symbolic Name	Description
	Q0.0	[G]	
	Q0.1	[G]	
	Q0.2	[G] Contactor_A	Safety output controlling contactor
	Q0.3	[G] Contactor_B	Safety output controlling contactor

*Names and description for outputs in Pluto 0.*



### 3.10 Programming the ladder logic

Open the window “PLC Code” by a left mouse click on the corresponding symbol in the tree in the left field. With a right mouse click a new network (rung) can be opened. A new network is always inserted after the network which the cursor is pointing at. A dialog box with three options is shown, of which one is “New Network”.

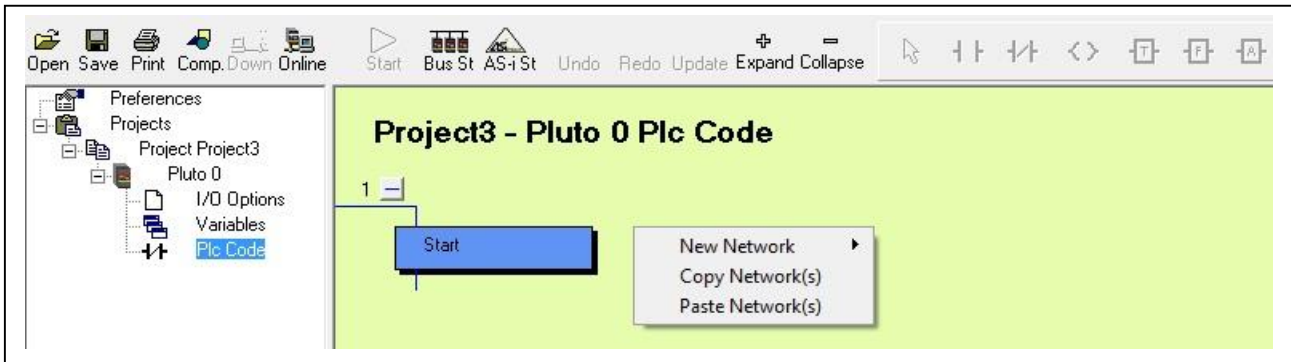

By pointing on “New Network” a new menu is expanded. The menu has two parts divided by a delimiter. Above the delimiter basic ladder functions are listed, and below the delimiter available function blocks can be accessed by clicking on “Function...”

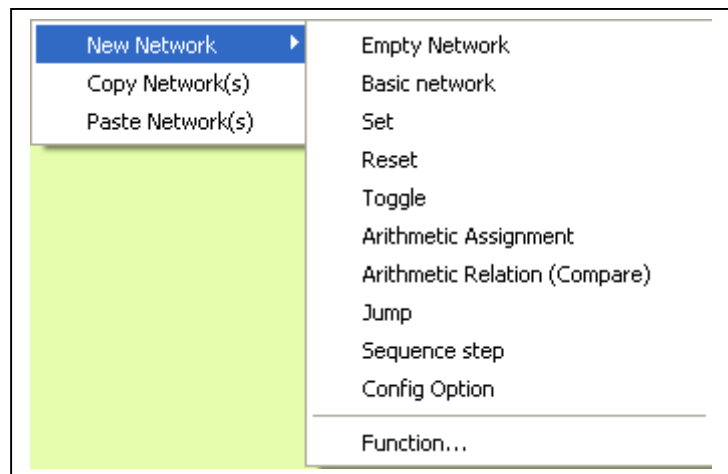

By clicking on “Function...” the menu below is shown, where available function blocks can be selected from the menu to the left. The block functions are described in a separate document.

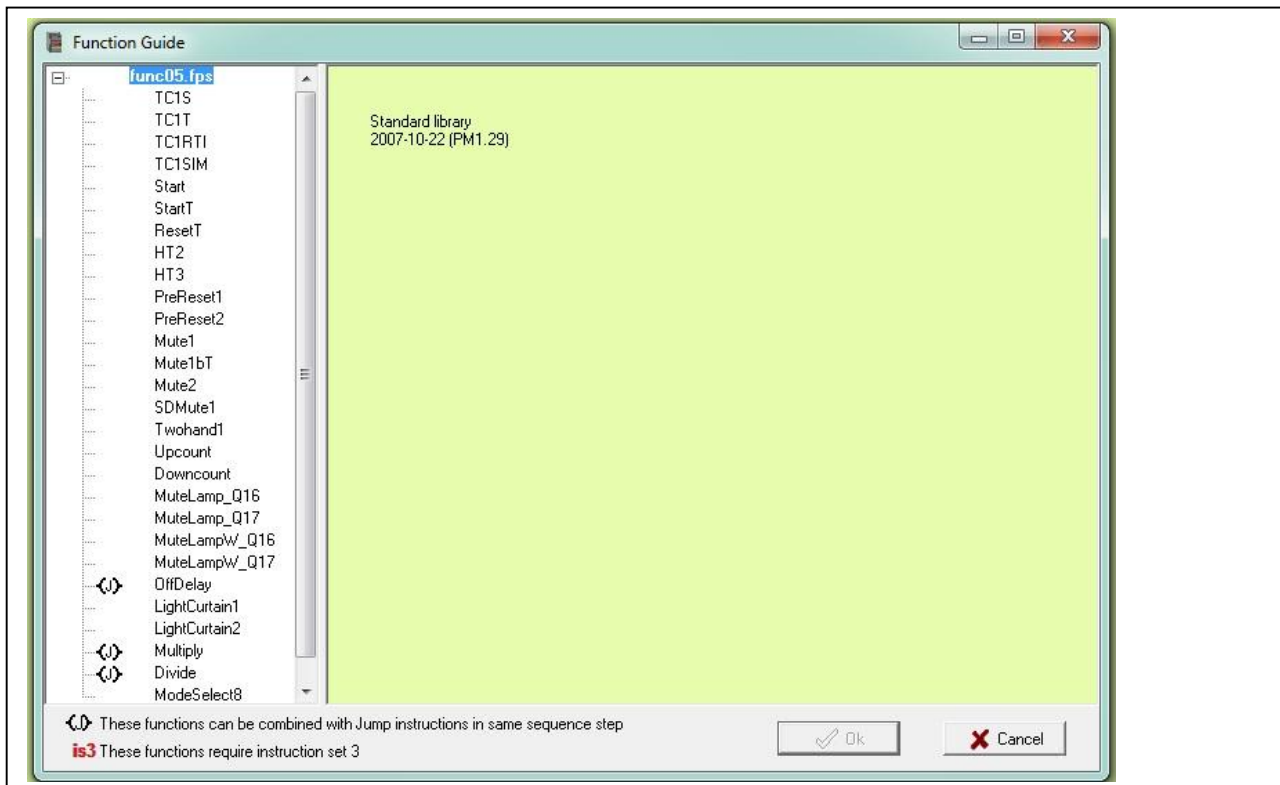



In this example we need a muting function and have found that the block “Mute2” is suitable. A left mouse click on “Mute2” followed by clicking “Ok” in the menu generates a ladder network showing the “Mute2” block.

The highlighting of the network means editing mode. Each network has to be edited separately.

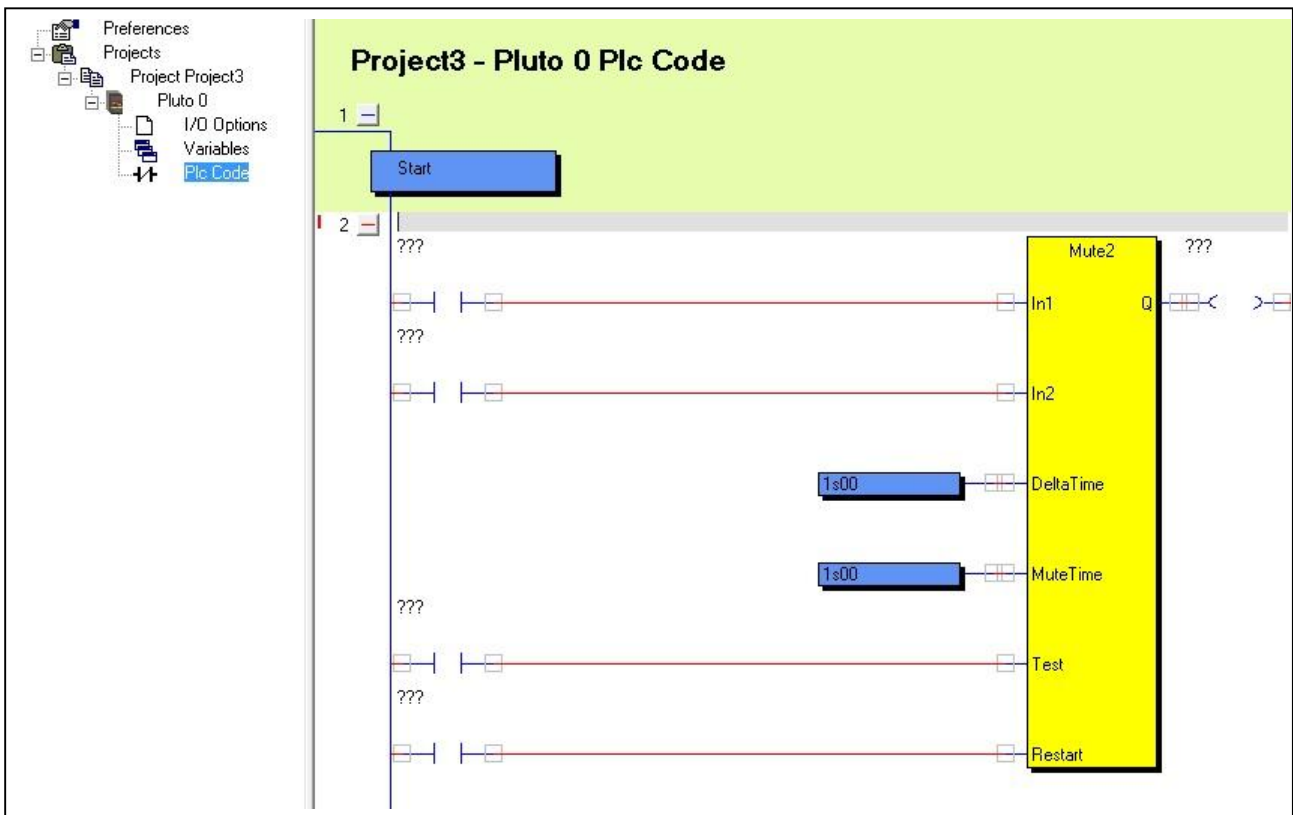

The ladder components which are marked “???” must now be defined or in some cases deleted. By a right mouse click on a component the menu to the right is shown. Except for the contact symbols (which are described later) there are three options. “Component Properties” leads to the next dialog box, “Disconnect Component” disconnects the component from the red connection lines, and “Delete component” deletes the component.

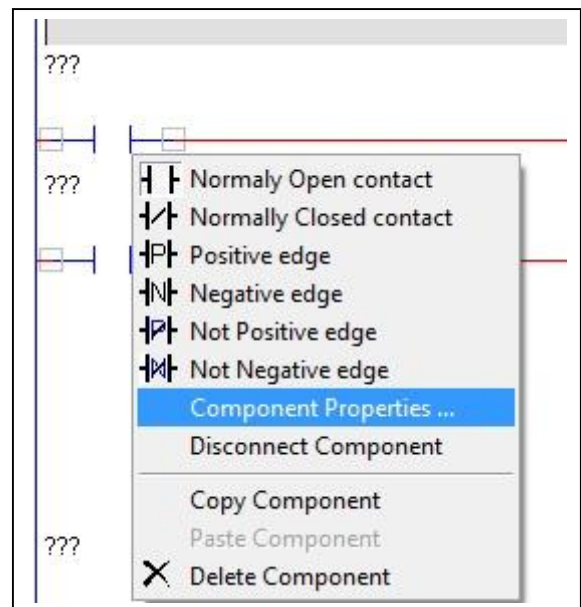

The property box for a contact symbol gives the choice for normally open, normally closed, positive or negative edge pulse function. There are two ways of entering a variable name, either giving the “Real variable name”, e.g. I0.0, I0.1, M0.3..., or by opening of the list under “Symbolic Variable Name”.

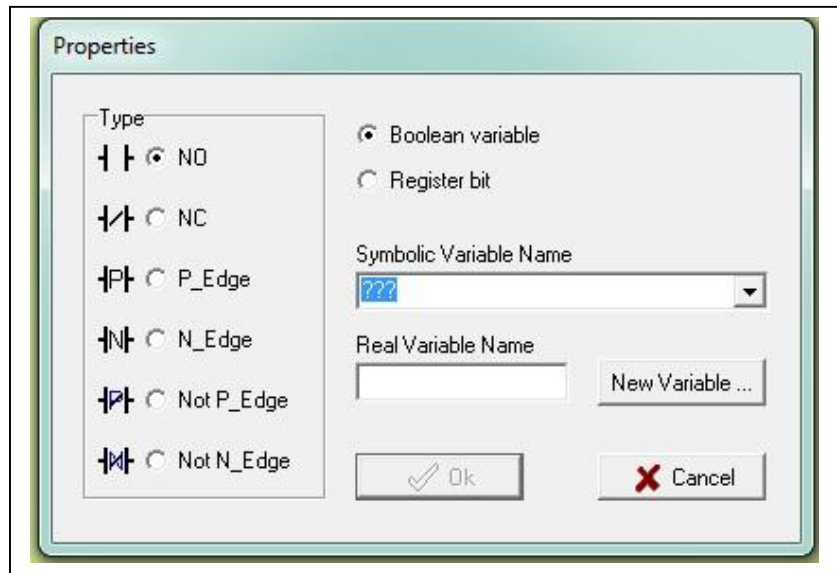

In the list under “Symbolic Variable Name” all variables which have been given a name can be found.

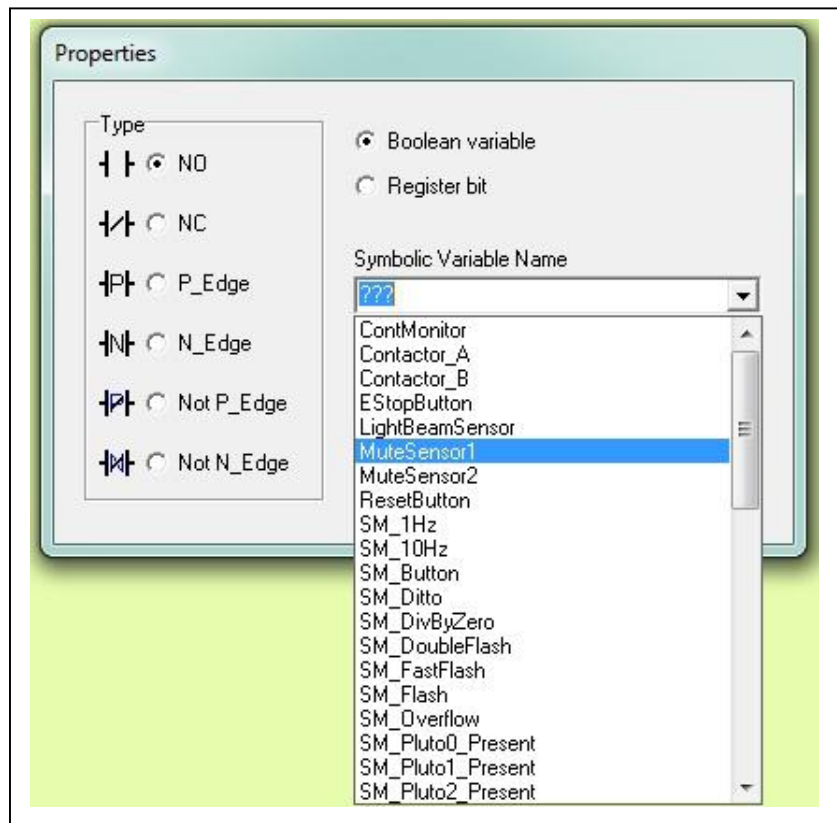

Confirm with a click on "OK".

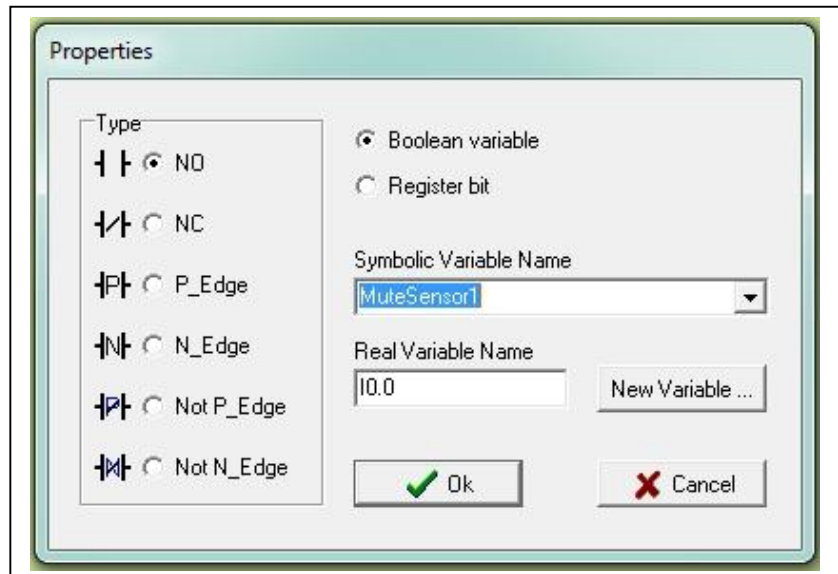

After selection, the component is labelled with both symbolic and real variable name.

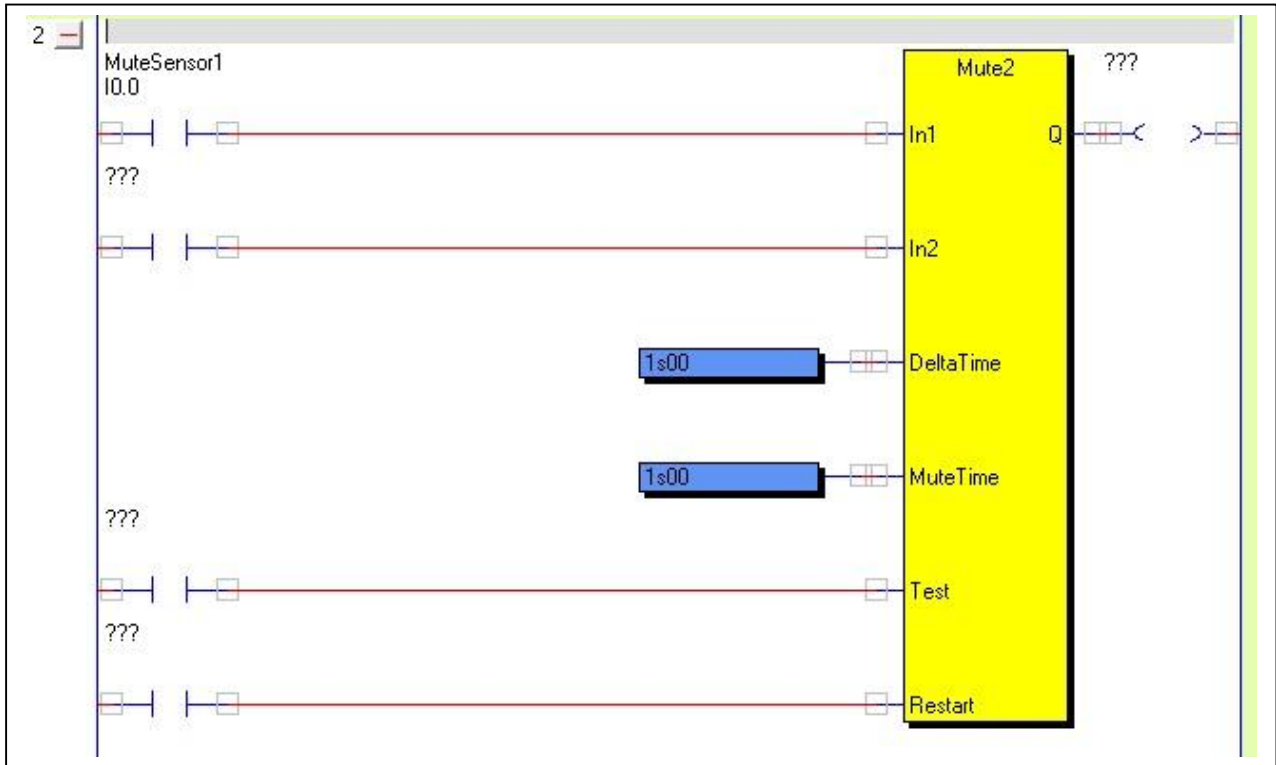

The timer values can be changed in the same way, but a different dialog box is shown where the timer value can be either specified as a constant or as the value from a register. “s” is used as the decimal point.

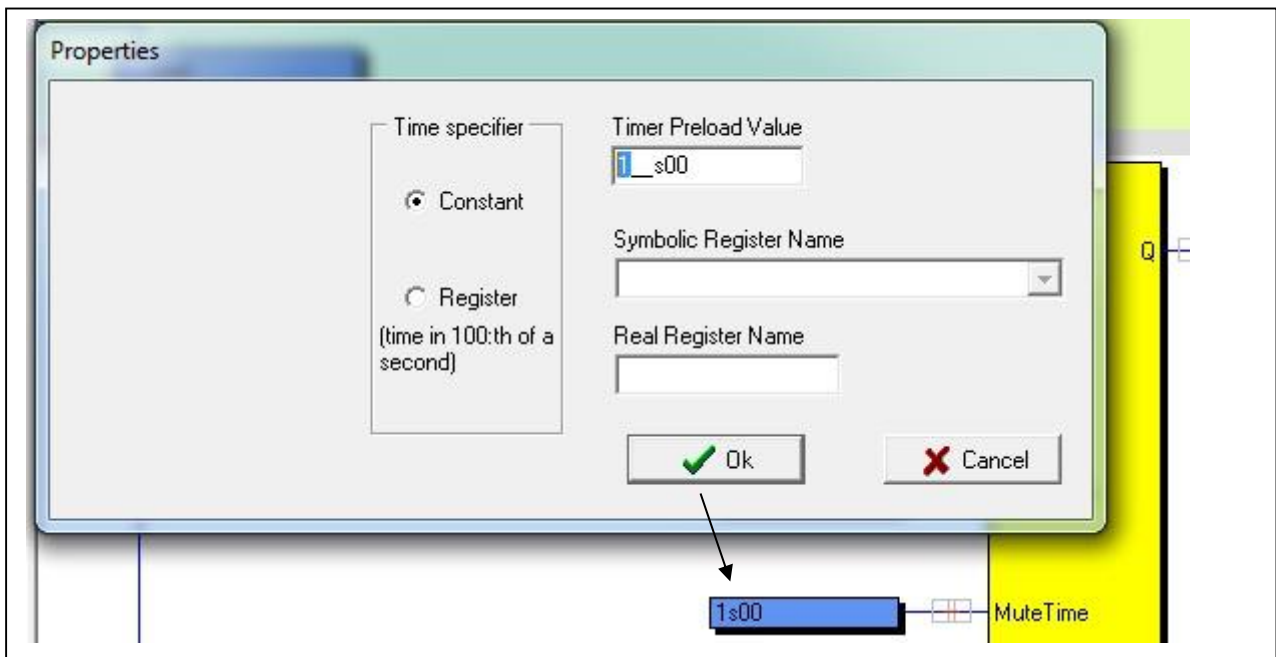

The output from a function block can be connected directly to a physical output (Q), a memory (M or GM) or to an input in another block, in this case a memory (M0.0).

By a double click on the ladder component we get a dialog box with different output functions.

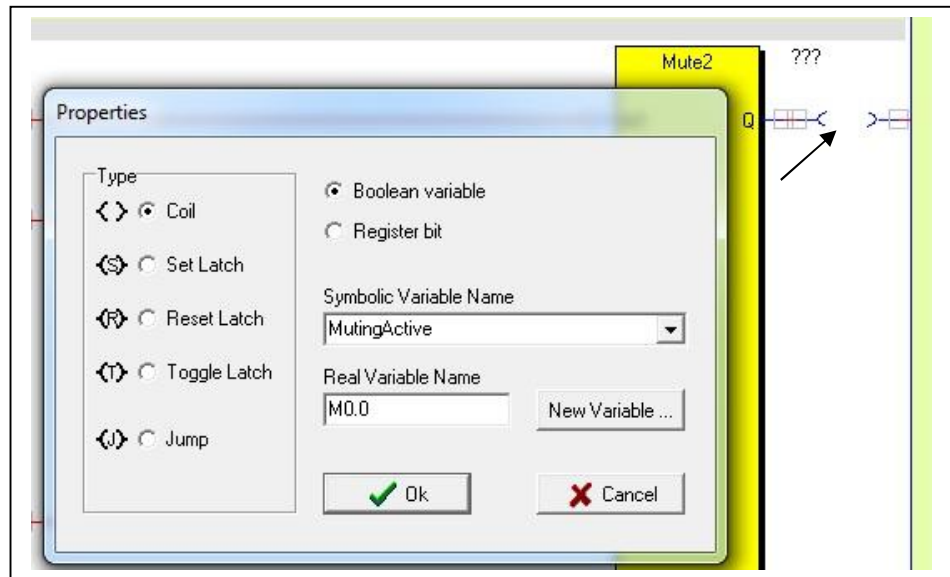

To avoid mistakes the memories should be given a name directly by use. This can be done by opening the window “Variables” during the editing of a ladder network (except when a dialog box is shown).

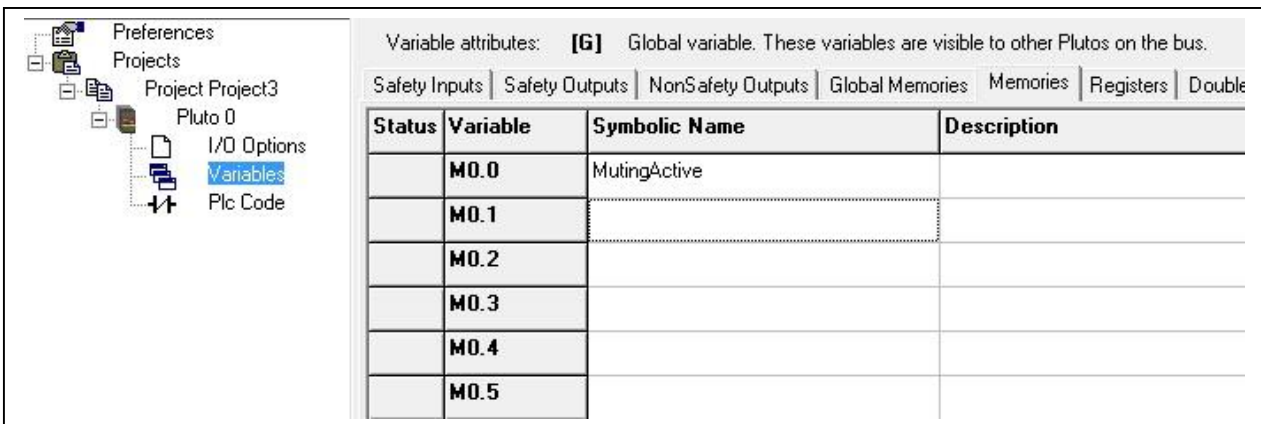

The input for Test on the “Mute2” function block shall not have any input condition in this example. The component is therefore deleted.

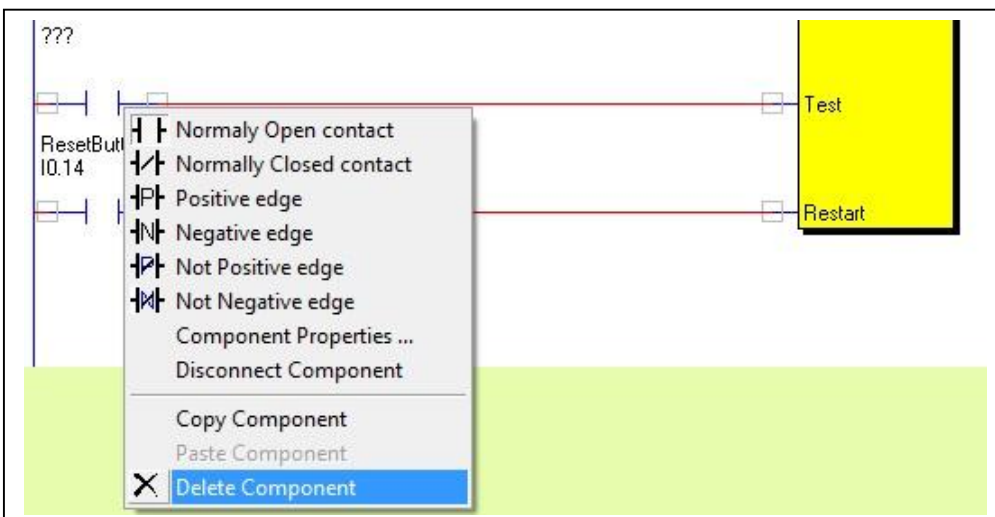

### 3.11 Adding comments and finalising the network

At the top of a network there is a field for comments. Everything that is typed on the keyboard during edit mode is written into this field.

When the editing of the network is completed it can be closed for editing by a left mouse click on "Update".

Alternative ways are:

- to press "F3" key or
- to press "Esc" followed by answering "Yes" in a dialog box.

If "Undo" is pressed, everything in the edited network is restored as it was before it was entered. Instead of "Undo", F2 can be used.

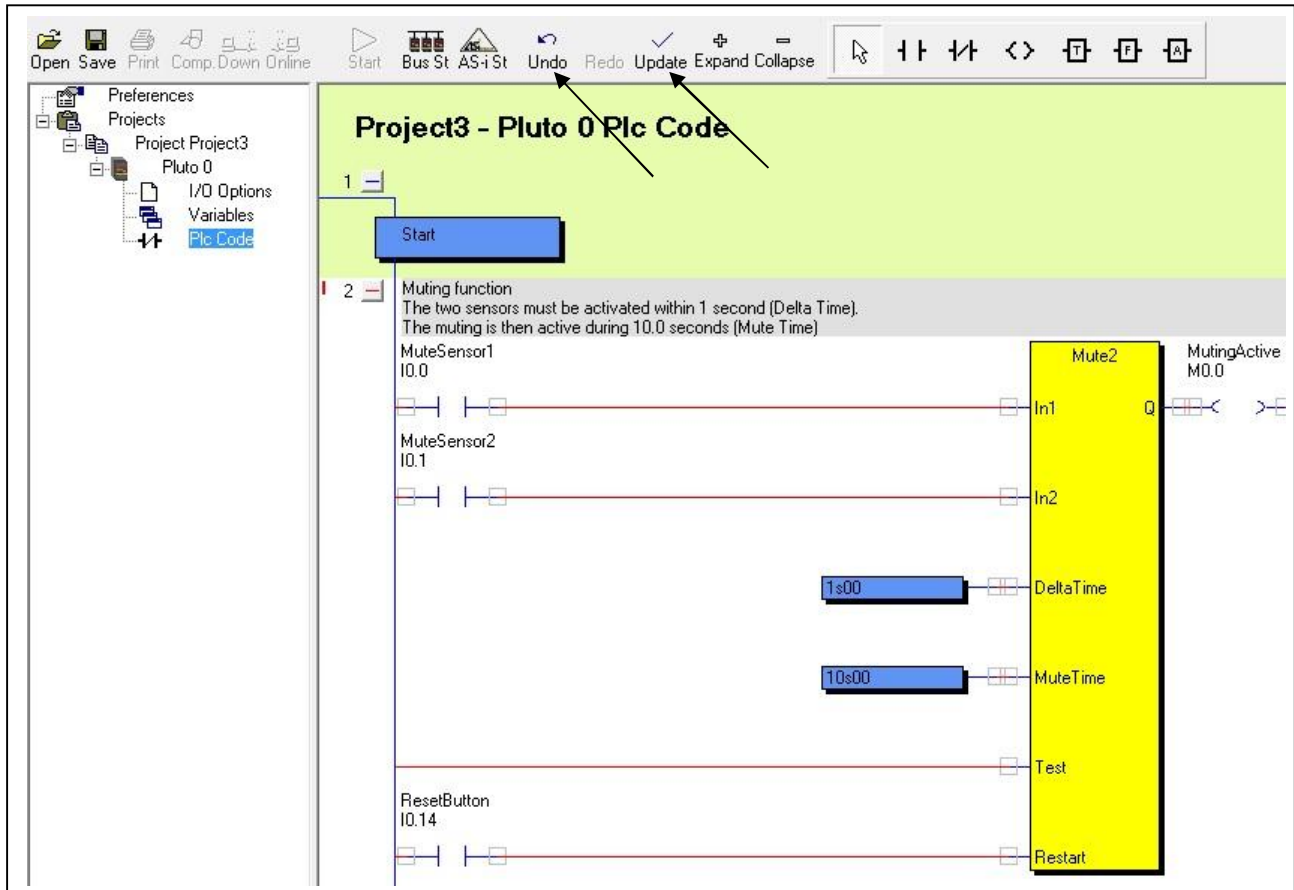

### 3.12 Next network

In the next network we shall put together our safety functions and set a safety output. Just for practice we select a “Basic network” instead of a function block this time.

Make a right click somewhere in the first network. Select “New network” and “Basic network”.

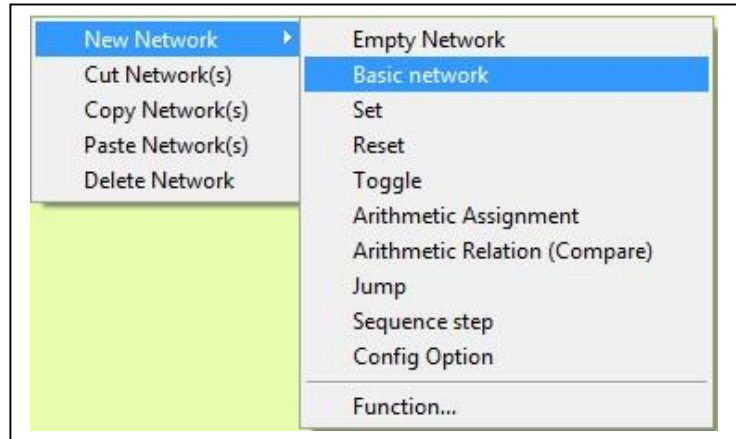

The result is that we get a network with one ladder NO contact and an output.

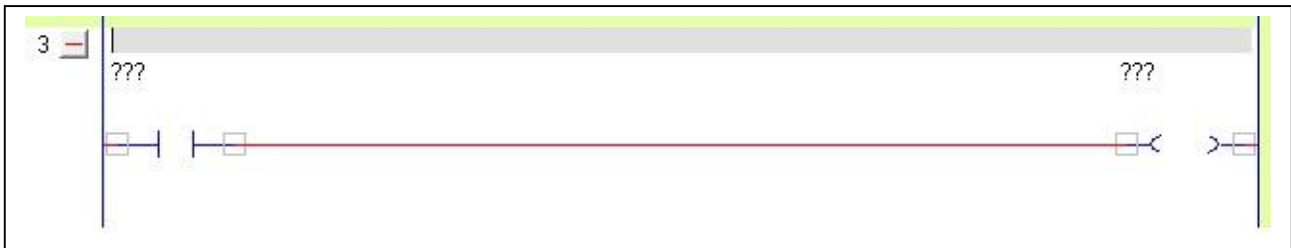

After deletion of the output and changing the properties for first ladder contact to “LightBeamSensor”, we start to put in new ladder functions by selecting from the toolbar. Make a left mouse click on the symbol for NO contact. The cursor then takes the form of the NO contact. Place the contact where you want to have it in the network, fix it with a left mouse click, and fill in the properties.

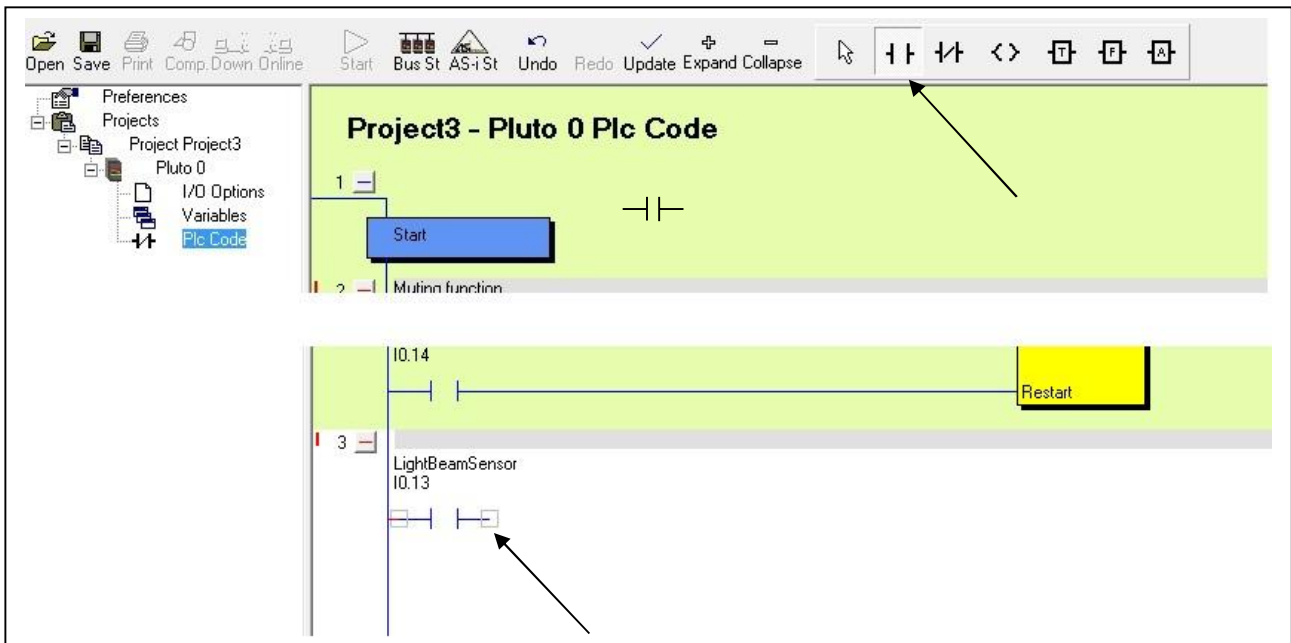



In this network we need a function block called “ResetT”. This is a block with one safety input which can handle monitoring of a Reset push button with an indicator. By clicking on the F symbol, the list with available function blocks is shown from where “ResetT” can be selected and inserted in the network.

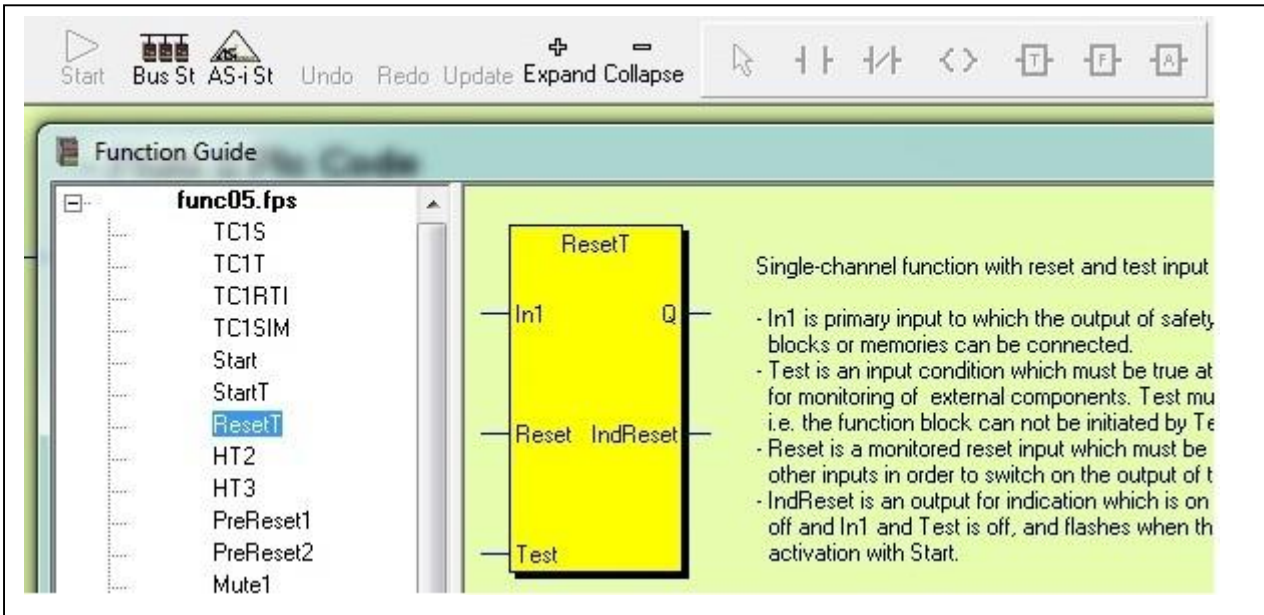

Continue selection of the other components needed in the same way. Function blocks can be found under the symbol F, Timers under “T” and arithmetic functions under “A”.

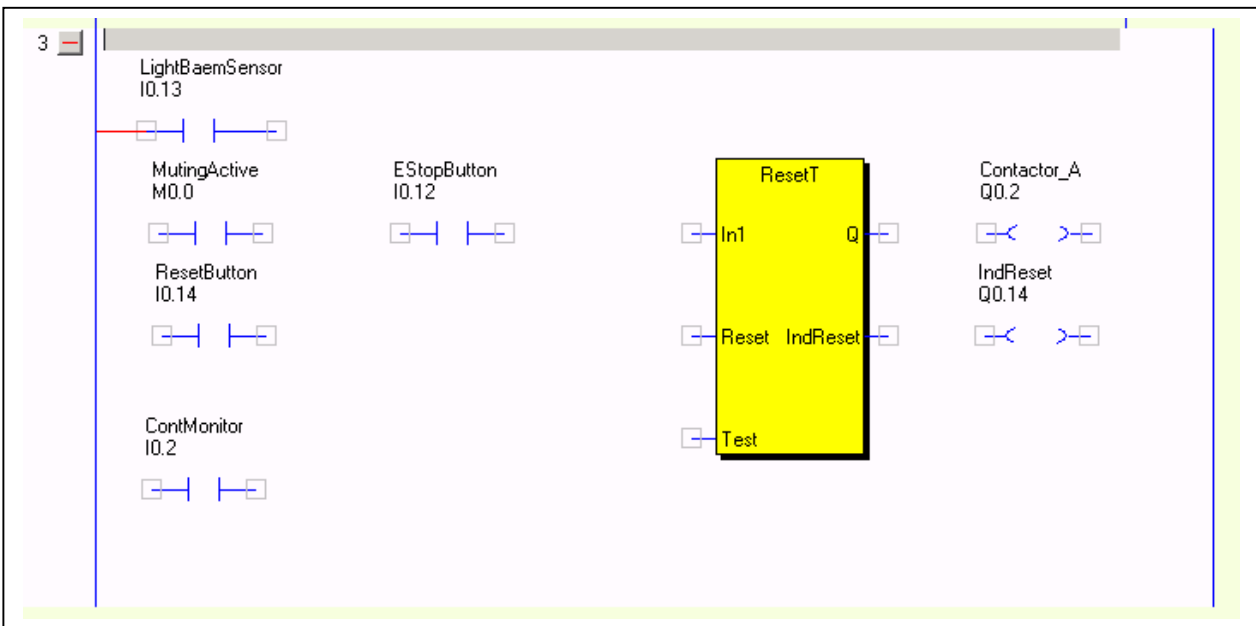



### 3.13 Connecting the components

When the arrow symbol in the toolbar is highlighted it is possible to draw, delete and change lines between the components. In this mode it is also possible to drag components around. The operations “Draw a line”, “Change a line”, “Change component properties”, “Change components” and “Moving components” are described in detail in chapter 12.1 “Edit mode”.

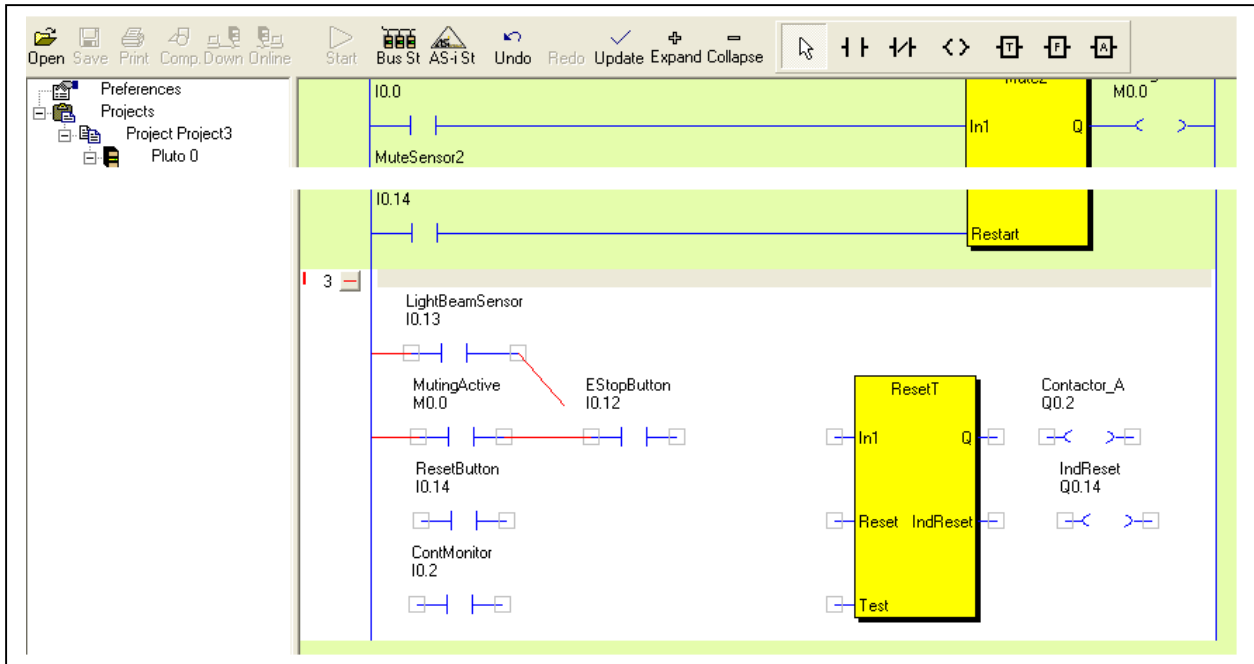

When all components are inserted and connected, press the “Update” button or F3. Note that the function block output “IndReset” is a secondary output. This block output can be left open if there is no use for it. If a component (Q, M or GM) is connected to it, the right side of this component shall be left open and not be connected to the right common line.

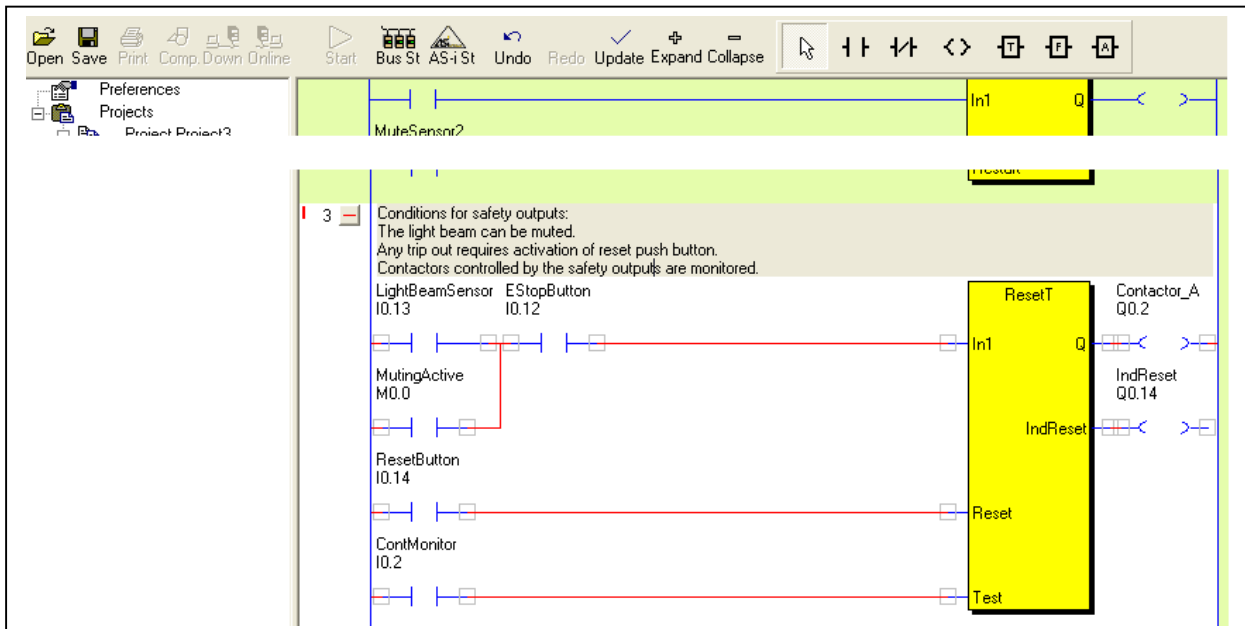

After updating we continue with the last network in this program. The safety function is to control the two contactors A and B, connected to different outputs. We shall program contactor B to work exactly as Contactor A. Instead of making an equal network as for contactor A, we can use “Contactor\_A” (Q0.2) which contains the logic result of the previous network. Open a new basic network, then open the “Properties” dialog box for the first contact. Select “Contactor\_A” from the list. Finally set the properties for the output to “Contactor\_B”.

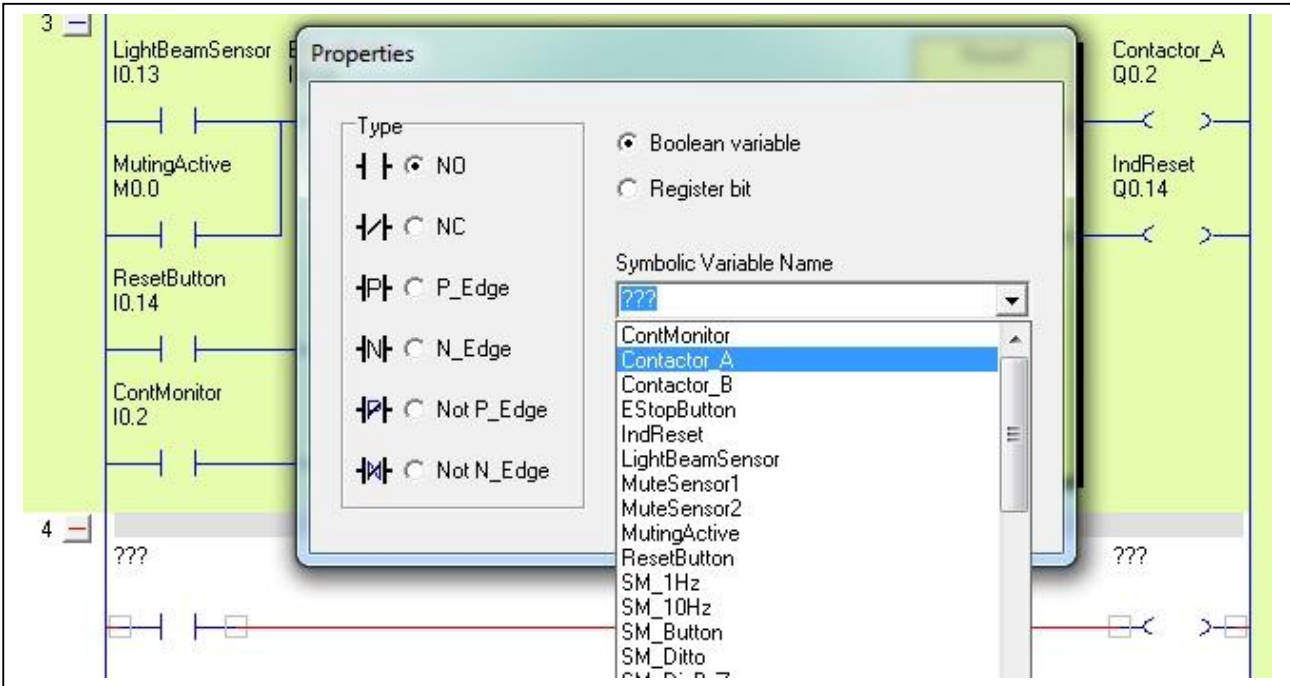

**Finished**

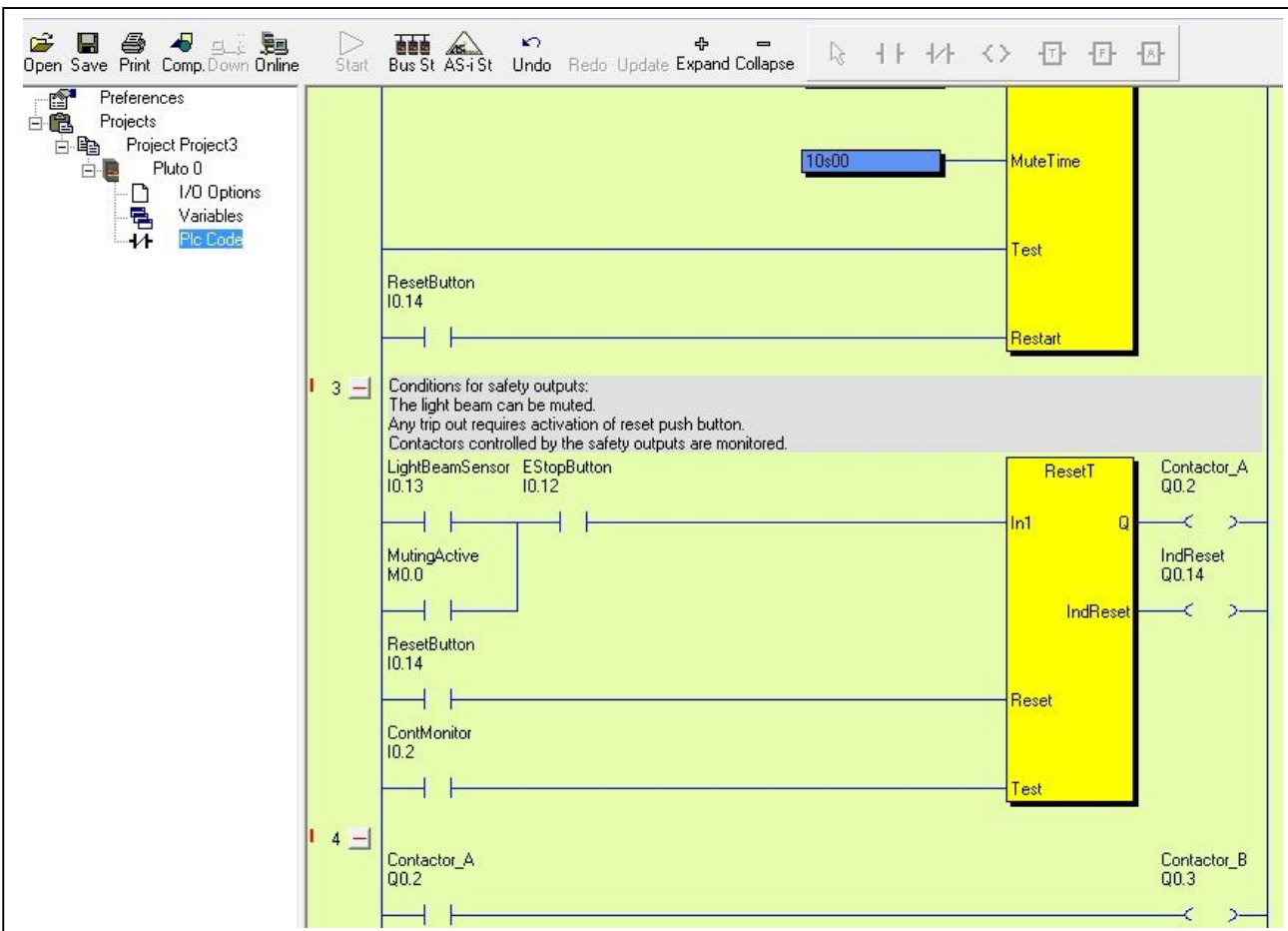

## 4 Projects Open, close, save, ....

After loading the Pluto Manager two fields are shown. The left field contains a tree menu which always is visible and is used to navigate between the different pages. These pages are shown in the right field on the screen. Several projects can be open simultaneously.

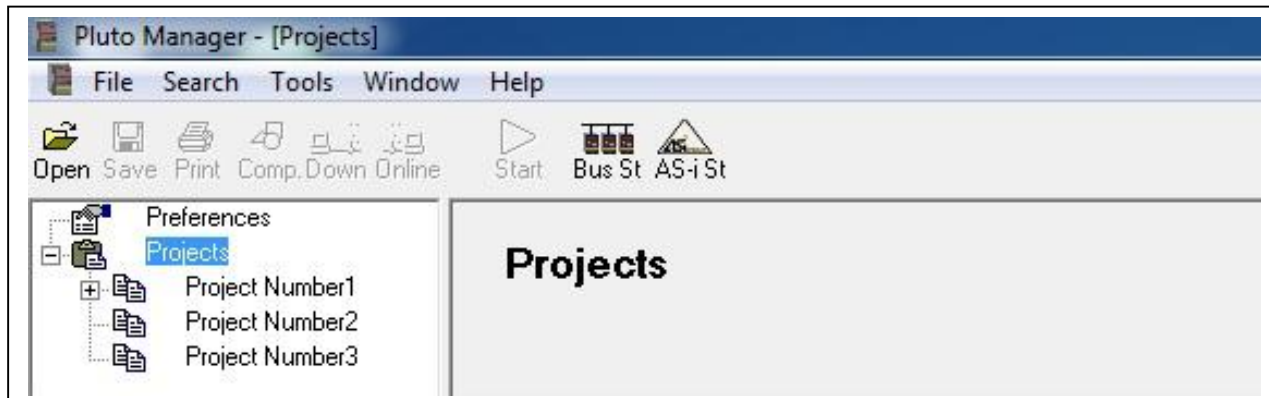

Commands:

- Open a new project:
- Right mouse click on "Projects" in the tree menu and select "New Project", or
  - Open "File"-menu à "New"
- Open an existing project:
- Right mouse click on "Projects" in the tree menu and select "Open Project", or
  - Use the shortcut "Open" in the toolbar, or
  - Open "File"-menu à "Open"
- Close project:
- Right mouse click in the tree menu on project name. Select "Close Project", or
  - Mark one of the open projects in the tree menu. Open "File"-menu à "Close Project".
- Save:
- Right mouse click in the tree menu on project name. Select "Save Project", or
  - Mark one of the open projects in the tree menu. Use the shortcut "Save" in the toolbar, or
  - Mark one of the open projects in the tree menu. Open "File"-menu à "Save Project".
- Save all:
- Open "File"-menu à "Save All". All open projects will be saved.
- Password protect:
- Open "File"-menu à "Password protect". See detailed description below.

## 4.1 Password protect

It is possible to protect the PLC code with a password. This will protect the program from being unintentionally changed, or changed by someone who doesn't have permission to do so. It is always possible to open a password protected file, but it cannot be changed without the password.

Select "File"/"Password protect":

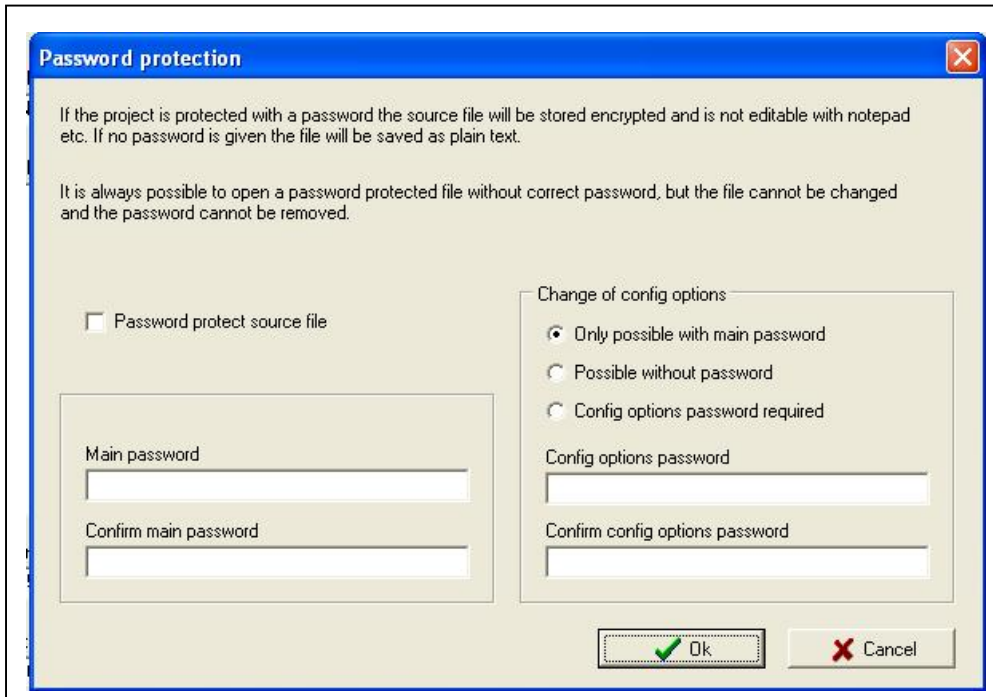

If the file is to be password protected, check the box "Password protect source file" and fill in Main password. To the right in the picture above are different choices for "Change of config options". This means that options (if used) can have different password protection than the rest of the PLC code.

### **Only possible with main password:**

With this setting the options have the same password protection as the rest of the program.

### **Possible without password:**

With this setting it is possible to set or reset options without any password. Nothing else in the code can however be changed without the password.

### **Config options password required:**

With this setting there is a special password for the option configuration. The main password still gives permission to change everything, including the options.

### 4.1.1 Opening a password protected file

When trying to open a password protected file this box appears:



#### **Open with full permission:**

This choice requires that the Main password is entered, and will give access to change everything.

#### **Open with permission to configure:**

If a "Config options password" has been defined, this password shall be entered. This will give access to the option configuration only. If no "Config options" password has been defined, then the Main password shall be entered. Note that this still only will give access to change the option configuration. If "Change of config options possible without password" has been selected earlier then no password is required here.

#### **Open in read only mode:**

No password is required and no changes will be possible.

#### **Remove password protection**

To remove password protection from a file, open it with full permission ("Open with full permission"), select "File"/ "Password protect" and clear the checkbox for "Password protect source file".

Password protect source file

Click OK.

## 5 Bus configuration

The Pluto units can work as separate units or together on the bus. A project can be set up to contain 1-32 Pluto units. The programs for all these units will then be stored in one .sps-file which is downloaded into each unit.

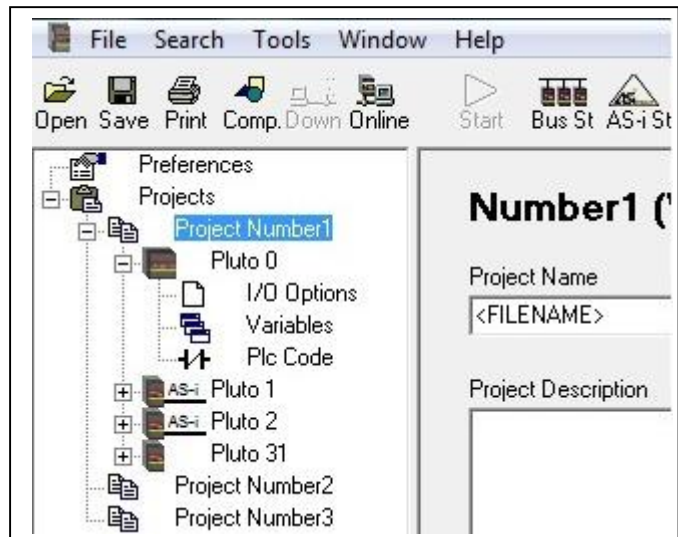

Command:

Right mouse click in the tree on "Project [name]" à "New Pluto"

Select Pluto family (type)

Enter a station number 0-31.

The station number is a part of the I/O addresses. Inputs in Pluto 0 are named: I0.0, I0.1, I0.2,... and in Pluto 1: I1.0, I1.1, I1.2,... etc..

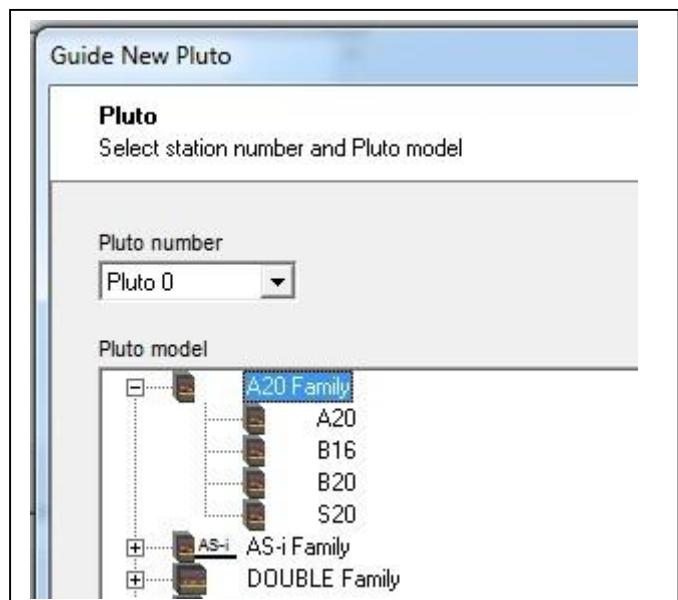

When clicking on one of the Pluto units in the project, as in this example Pluto 0, the following page is shown.

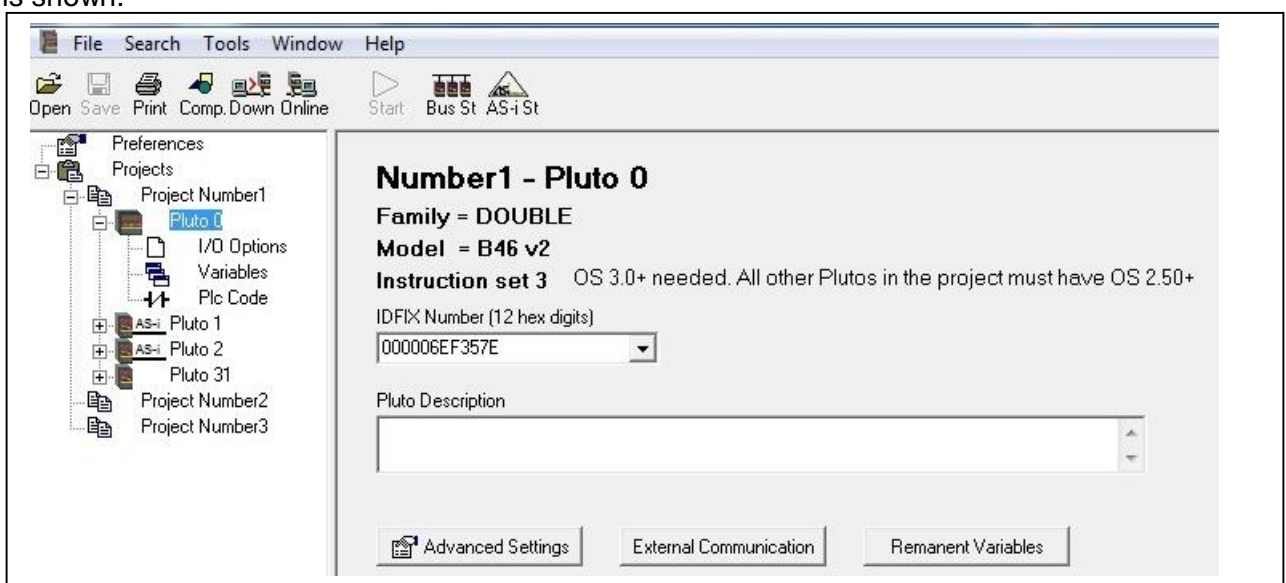

## 5.1 Identifier IDFIX number

When there are several Pluto units on the bus, each is equipped with an external identifier circuit containing a unique hexadecimal number. (See also Hardware manual.)

The identifier number shall be filled in to the field “IDFIX Number”. Since the numbers are not known at this stage of the project, it can be left out until it is time for download and test of the system.

If the project only contains one Pluto and no IDFIX is used, then “No IDFIX” shall be selected from the drop down list.

If an “IDFIX-PROG” (described in the Hardware manual) is used, “IDFIX-PROG” shall be selected from the drop down list.

The field “Pluto description” is just for comments and descriptions and is not downloaded to the Pluto unit.

### 5.1.1 Read IDFIX number from Pluto

With Pluto Manager 2.20 or later, and Pluto OS 3.4 or later, it is possible to read the IDFIX number from Pluto by clicking the button “Read IDFIX number from Pluto” in Pluto Manager.

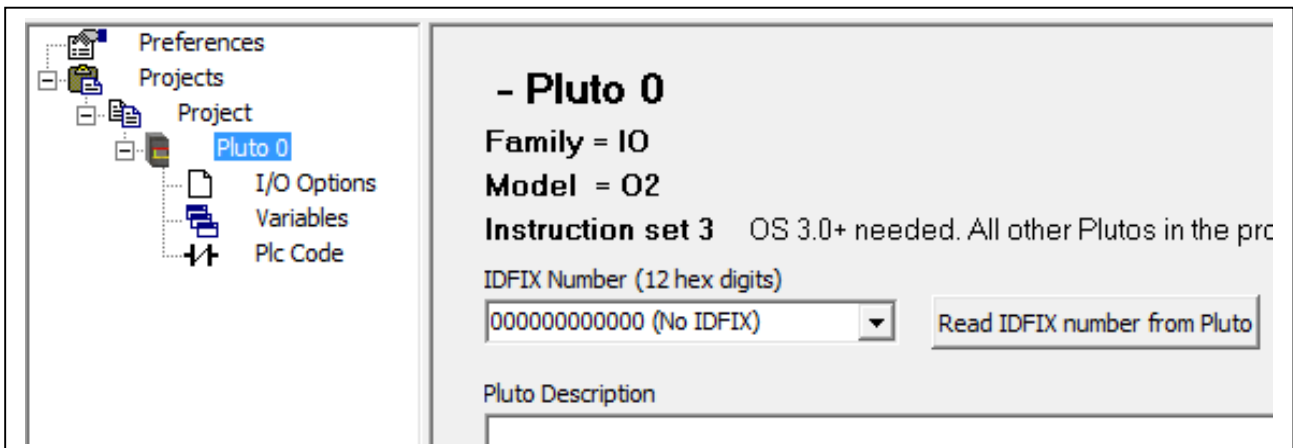
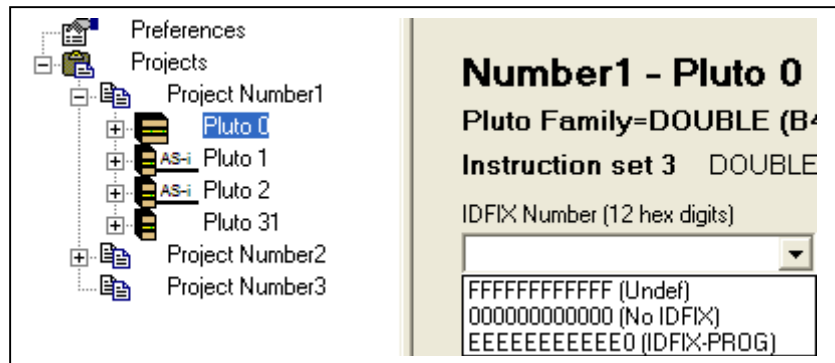



## 5.2 Advanced settings

If the “Advanced settings” button is clicked, the CanBus Cycle Time can be changed. This is described further in the Hardware Manual, but as the text in the picture says: These settings have influence on the system response time. Do not change these values without a good knowledge of the function of the system.

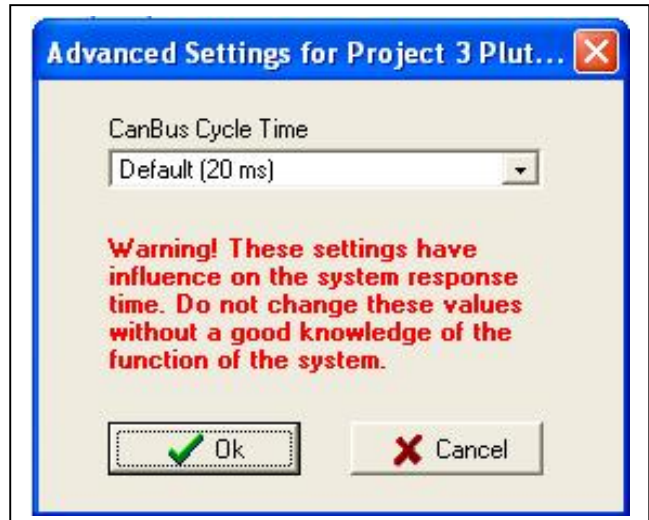

## 5.3 External communication

If the button “External Communication” is clicked this dialog box is shown. This function is used when a Pluto is to receive data from a Gateway via the Pluto bus. Further description is to be found in the Pluto\_Gateway\_Manual.

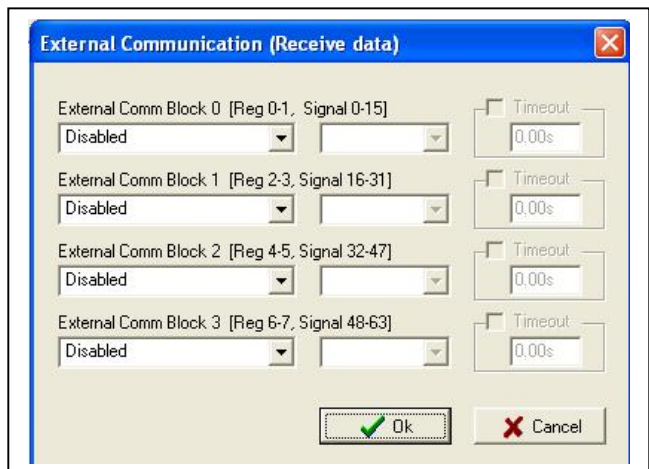



## 6 I/O Options

The “I/O Option” page is shown by a mouse click on the corresponding icon in the tree menu. The settings are filled in by using the drop down lists and tick boxes. Illegal combinations are automatically blocked.

The I/O option page for the different Pluto types looks similar; only the amount of I/O differs.

The screenshot shows the 'I/O Options' configuration window. The left sidebar contains a tree view with the following structure:

- Preferences
- Projects
  - Project Number1
    - Pluto 0
    - AS-i Pluto 1
    - AS-i Pluto 2
    - AS-i Pluto 31
    - I/O Options** (selected)
    - Variables
    - Plc Code
  - Project Number2
  - Project Number3

The main configuration area is divided into two sections:

### Failsafe inputs

Signal	Type of signal	Signal shape	Options
I31.0	Input	Static	<input type="checkbox"/> Non_Inv <input type="checkbox"/> No_Filt
I31.1	Input	A_Pulse	<input checked="" type="checkbox"/> Non_Inv <input type="checkbox"/> No_Filt
I31.2	Input	A_Pulse	<input checked="" type="checkbox"/> Non_Inv <input type="checkbox"/> No_Filt
I31.3	Undefined		<input type="checkbox"/> Non_Inv <input type="checkbox"/> No_Filt
I31.4	Undefined		<input type="checkbox"/> Non_Inv <input type="checkbox"/> No_Filt
I31.5	Undefined		<input type="checkbox"/> Non_Inv <input type="checkbox"/> No_Filt
I31.6	Undefined		<input type="checkbox"/> Non_Inv <input type="checkbox"/> No_Filt
I31.7	Undefined		<input type="checkbox"/> Non_Inv <input type="checkbox"/> No_Filt

### Failsafe inputs / Non failsafe outputs

Signal	Type of signal	Signal shape	Options
IQ31.10	Output	A_Pulse	<input type="checkbox"/> Non_Inv <input type="checkbox"/> No_Filt
IQ31.11	Undefined		<input type="checkbox"/> Non_Inv <input type="checkbox"/> No_Filt
IQ31.12	Input	A_Pulse	<input type="checkbox"/> Non_Inv <input type="checkbox"/> No_Filt
IQ31.13	Input	A_Pulse	<input type="checkbox"/> Non_Inv <input type="checkbox"/> No_Filt
IQ31.14	Light button	A_Pulse	<input type="checkbox"/> Non_Inv <input type="checkbox"/> No_Filt
IQ31.15	Undefined		<input type="checkbox"/> Non_Inv <input type="checkbox"/> No_Filt
IQ31.16	Undefined		<input type="checkbox"/> Non_Inv <input type="checkbox"/> No_Filt
IQ31.17	Output	Static	<input type="checkbox"/> Non_Inv <input type="checkbox"/> No_Filt

# 7 AS-i bus functions



(Only for Pluto AS-i and B42 AS-i, see also Pluto\_Hardware\_Manual)

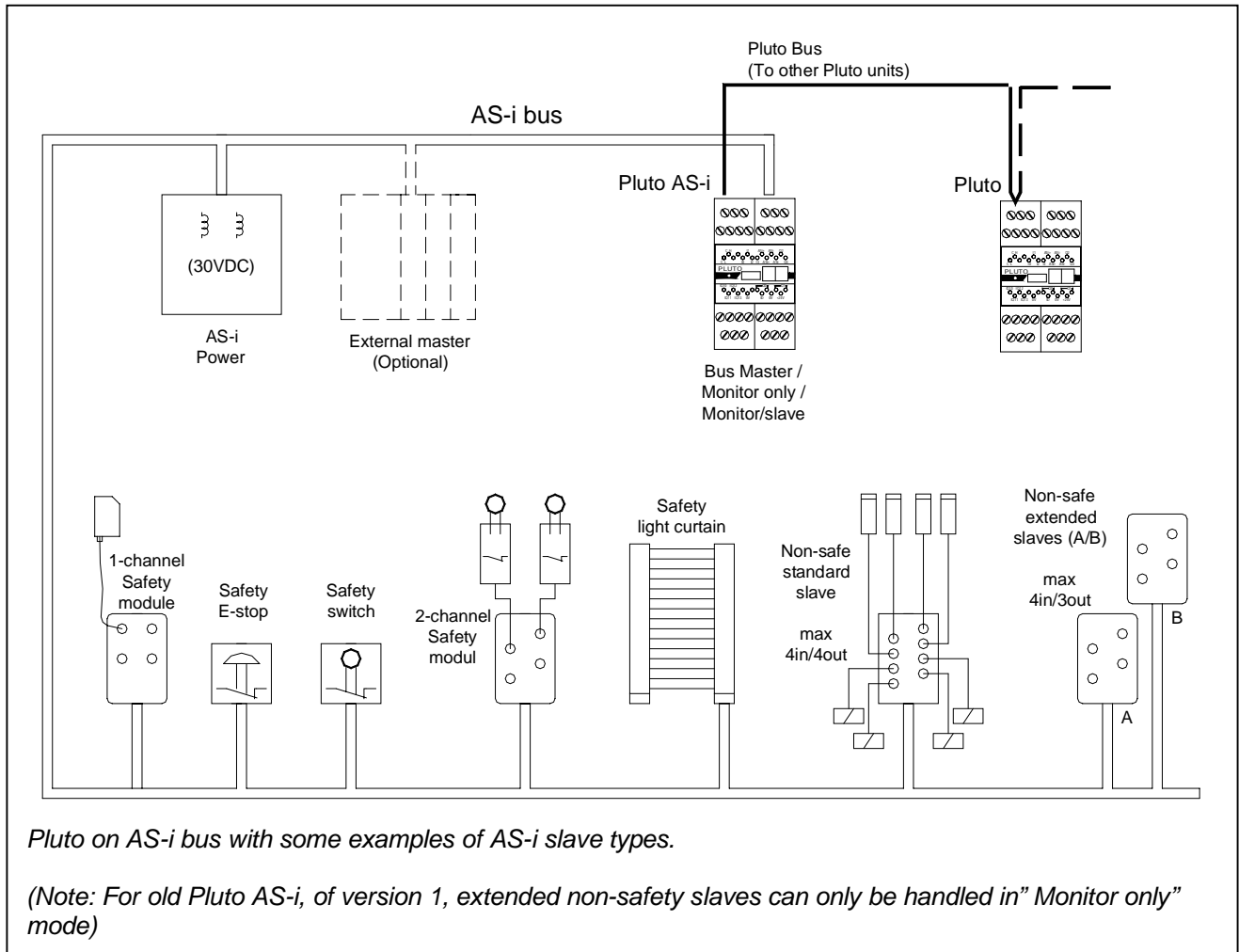

## 7.1 Initial configuration of AS-i functions

The following will show the steps to configure a Pluto AS-i or a B42 AS-i.

### 7.1.1 "New Pluto", selection of family and station number

Put the cursor in the left side tree menu, make a right mouse click and select "New Pluto" (as described in 5).

Select Pluto "AS-i" or "B42 AS-i" from the list and select station number on the Pluto bus.

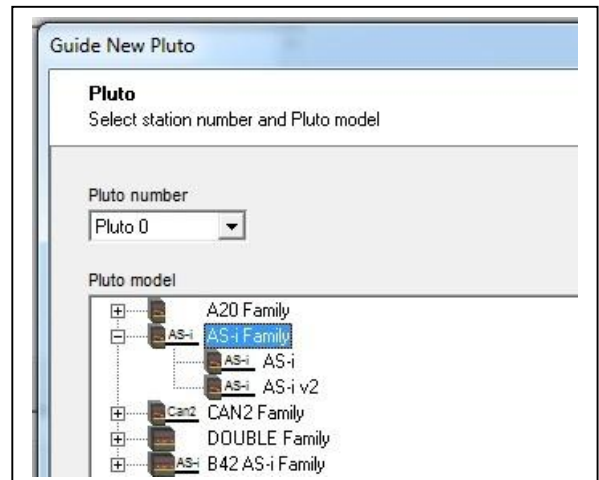

If AS-i v2 or B42 AS-i was selected, the question about “instruction set 2” or “instruction set 3” will appear.  
(Described under 3.6.1 and in Part 2 of this manual.)

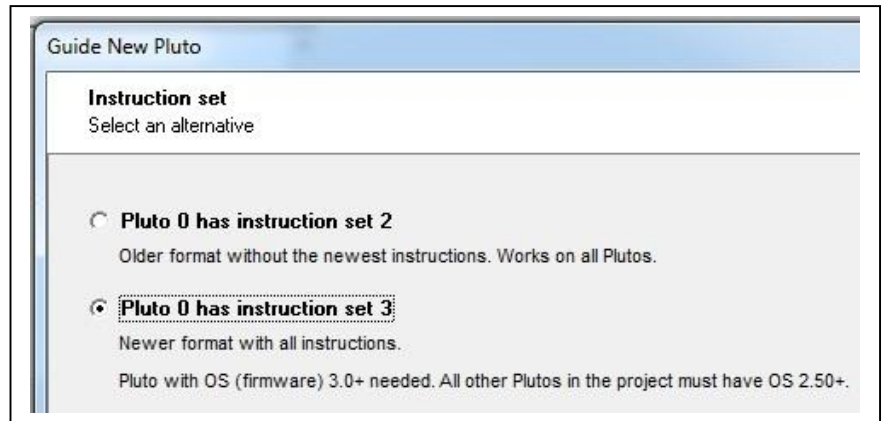

### 7.1.2 Working mode on the AS-i bus

After selection of an AS-i Pluto the question of mode appears.

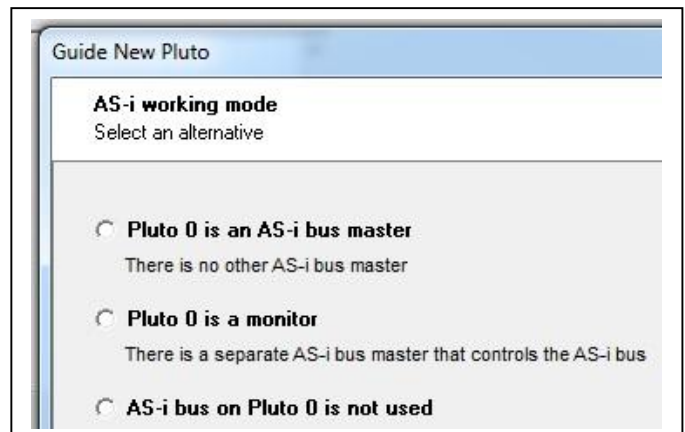

**Pluto is an AS-i bus master (Master mode)** shall be selected if no other master exists on the bus. Pluto controls the bus totally. For the user the main difference is that Pluto can set the outputs in non-safety slaves.

**Pluto is a monitor (Monitor/slave mode)** shall be selected if there exists an external master together with Pluto. Normally the external master is a standard non-safety PLC system controlling the non-safety part of the non-safety slaves on the AS-i bus together with Pluto which only reads the AS-i slaves. However even if Pluto only is a monitor it can read all IO data regarding the safety slaves of course, but also both inputs and outputs in the non-safety slaves.

**AS-i bus on Pluto is not used** shall be selected if the AS-i functionality/AS-i bus is not used.

### 7.1.2.1 Variants of monitor mode:

If monitor mode is selected a new dialog with three selections appears.

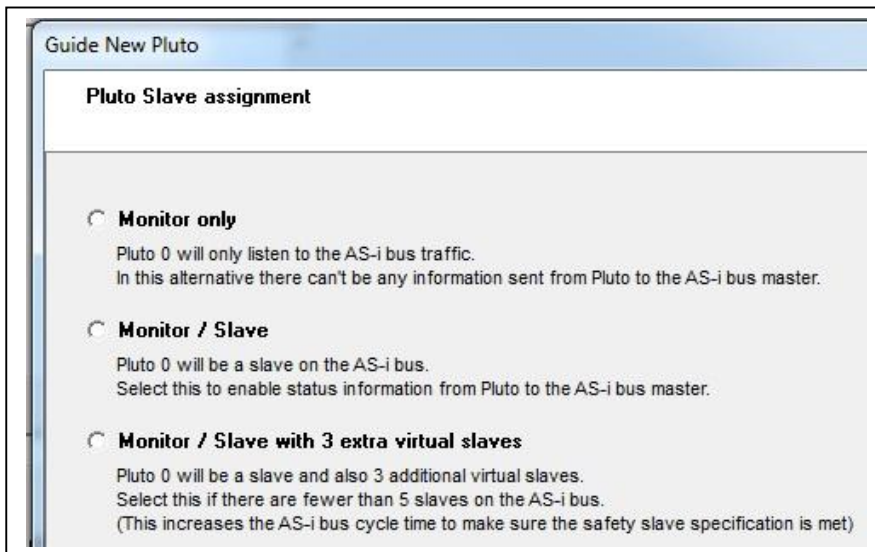

**Monitor only:** An external master controls the bus and Pluto listens to the traffic and reads the I/O information of all slaves. (Both safe inputs and non-safe input/outputs).

**Monitor / Slave:** Same as Monitor only but Pluto is also acting as a non-safety slave under the external master which means that Pluto and the external master can exchange 4 bit data in each direction with each other. If this mode is selected, the slave address also has to be selected.

**Monitor / Slave with 3 extra slaves:** Same as Monitor /Slave but with three extra dummy slaves. This mode shall be selected when there are less than 5 AS-i slaves connected to the bus. (The reason is that if there are only a few slaves on the bus the AS-i cycle time is shorter and if it is too short the safety slaves have not enough time to update the safety code.)

### 7.1.3 Page for AS-i specific setup

By clicking on “AS-i Options” in the tree menu to the left the special page for AS-i specific settings is shown.

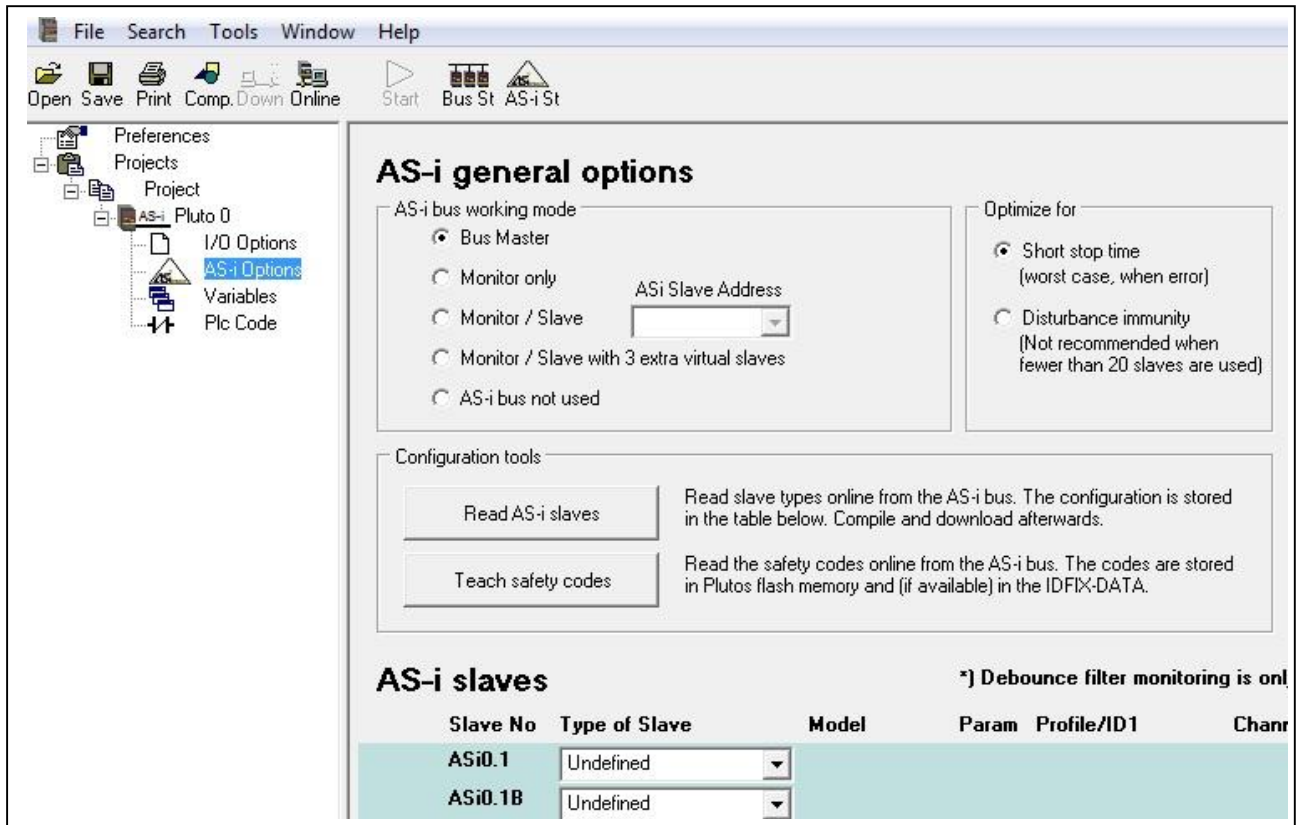

#### Working modes:

Even if the working mode was selected immediately by selection of a Pluto AS-i it can be modified afterwards. As the picture shows there are three selections for Monitor mode.

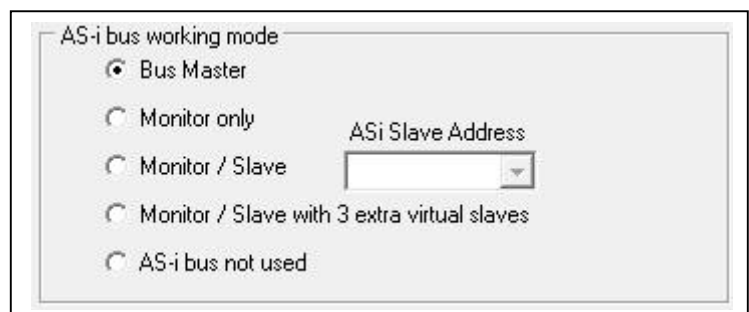

#### Optimization “Short stop time” or “Disturbance immunity”

As the picture tells Short stop time should be selected when there are fewer than 20 slaves on the bus. By selection of disturbance immunity the system can withstand disturbances on the AS-i bus better, but the worst case stop time increases 10 ms.

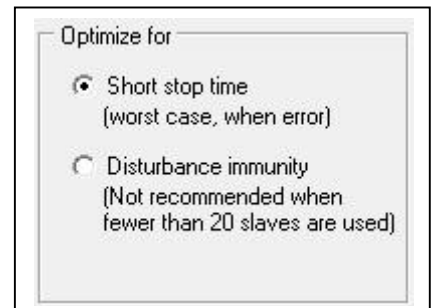

### 7.1.4 Manual configuration of slave types (profiles)

In the next chapter, 7.2, semi automatic configuration is described. However this requires online communication with the Pluto AS-i, and since the programming often is made before the system is installed or the programmer is not by the system during the design the configuration can also be made manually. If the programmer ignores to fill in the table during the off line programming the only effect is that at compilation the compiler will show warnings that the slaves are not configured.

Up to 31 slaves (or 62 A/B slaves) can be connected to the AS-i bus, and they can manually be configured in Pluto Manager under AS-i Options, "Type of Slave" for each Slave No. As the picture illustrates there are 8 options.

AS-i slaves						*) Debounce filter monitoring is only valid for OS ver 3.0+
Slave No	Type of Slave	Model	Param	Profile/ID1	Channel Monitoring	
ASi1.1	Safe Input	General	F	S-0.B.0 ID1=F	Channel monitoring	
ASi1.2	Undefined					
ASi1.2B	Safe Input					
ASi1.3	Nonsafe Std					
ASi1.3B	Nonsafe A					
	Combined Transaction A					
	Analog					
	Safe Output					
	Pluto as Safe Input					

For all selections except "Undefined", "Safe Output", and "Pluto as Safe Input" a box under "Profile/ID1" will appear. By clicking on this an AS-i profile box is shown, where the slave profile manually can be entered. (This applies for Pluto as "Bus Master". For "Monitor Mode" the appearance is a bit different, see 7.2.1.1 Configuration in Monitor mode.)

AS-i Profile

Profile for ASi1=5-7.B.F ID1=F

I/O configuration: 7 ( Outputs )

ID code: B ( Safe slave )

ID2: F

ID1: F

Ok Cancel

Below is an explanation of the different slave types followed by a table describing the input and output variable names for each slave type.

#### 7.1.4.1 Undefined

Undefined shall be selected if no slave is to be used on this address.

### 7.1.4.2 Safe input

A safe input slave has physically a dual channel input but in Pluto/Pluto Manager it is configured as one input. The slave can also have up to 4 non-safe outputs. For naming of variables see the table under 7.1.4.4 Nonsafe A/B slaves.

When Safe input is selected the following page is shown:

Under “**Model**” there is another drop down list where the type of safe input slave can be selected. For all slave types except Urax, select “General”. For Urax slaves, select the correct Urax model.

By clicking on “**Param**” the slave parameter can be set. This parameter setting dictates which mode the slave operates in.

*For Urax-A1R this picture is shown.*

*For “General” this picture is shown.*

“**Profile/ID1**” is a description of the slave stating the number of inputs/outputs, if it is a non-safe or safety slave, A/B slave, etc. Explanation of the profile codes can be found in different literature but here are some examples:

S-0.B... - Safe slave

S-7.B... - Safe slave with outputs

S-7.0... - Standard non-safe slave with 4 inputs and 4 outputs.

“Profile/ID1” does not have to be selected for Urax slaves, since this is done automatically by selecting the correct Urax type. For other slave types than Urax, see the manual for correct setting.



## “Channel Monitoring”

Many of the safety nodes have dual channel input. The user can select different kinds of channel monitoring for these devices.

- No channel monitoring: Both channels must be on, but no channel monitoring. Normal setting for single channel slaves.
- Channel monitoring: The default setting. If one channel opens, the other also has to be opened before they close again.
- Chan mon & debounce filter\*: As with channel monitoring, but there is a time from where both channels are on where contact bounces are allowed.  
The input is considered as on as soon as both channels are on, but will shortly fall if there are contact bounces.  
This mode is suitable for example for doors with mechanical switches.
- Simultaneously: As with channel monitoring, but there is a maximum time between the two channels off on transitions.
- Simultaneously & debounce\*: As simultaneously, but contact bounces are allowed within the specified time.  
The input is considered as on as soon as both channels are on, but will shortly fall if there are contact bounces.

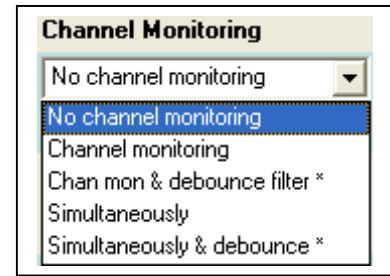

\*OS version 3.0 or later

For all URAX models except URAX-C1 the Channel Monitoring setting is inhibited. This is because (with exception for URAX-C1) the channel monitoring is handled by URAX.

## “Time limit”

If “Simultaneously” has been selected the desired time limit in seconds can be entered here.

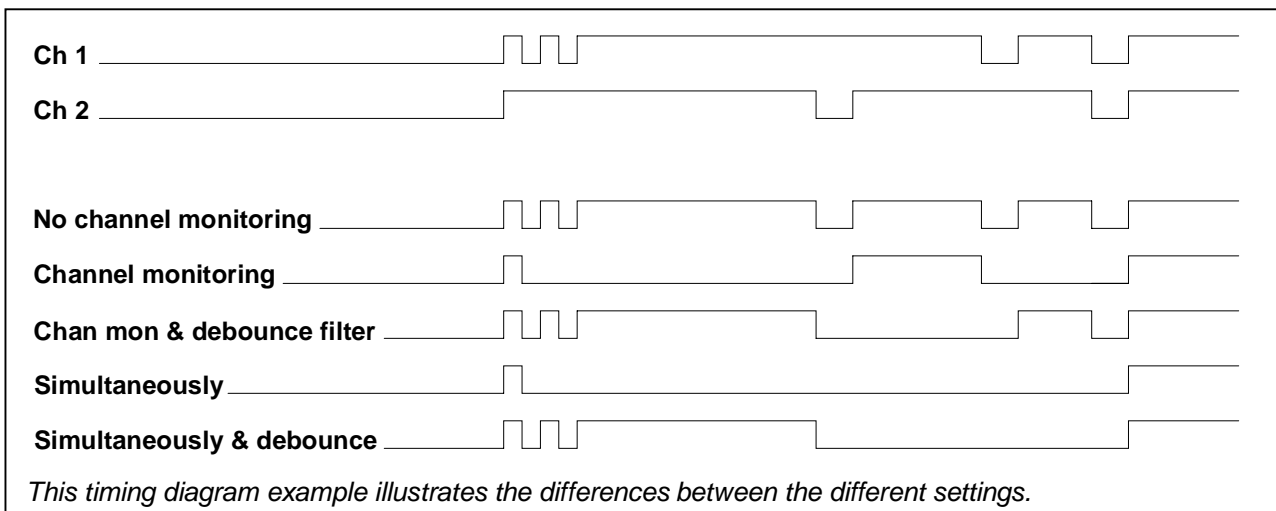



### 7.1.4.3 Nonsafe Standard slaves

A non-safe standard slave can have up to 4 local non-safe inputs and/or up to 4 local non-safe outputs. For naming of variables see the table below.

### 7.1.4.4 Nonsafe A/B slaves

Two A/B-slaves (one A-slave + one B-slave) share the same address number. This means that up to 62 A/B-slaves can be used in a net, instead of 31 which is the maximum number for other slave types. A non-safe A/B-slave can have up to 4 inputs and 3 outputs. Both inputs and outputs are local. For naming of variables see the table below.

"Type of Slave" setting				
	Safe Input (Slave 1-15)	Safe Input (Slave 16-31)	Nonsafe Std	Nonsafe A (Nonsafe B)
Global Safety Inputs	ASi_x	-	-	-
Local Safety Inputs	-	ASi_x	-	-
Local NonSafety Inputs	-	-	ASi_x.1 ASi_x.2 ASi_x.3 ASi_x.4	ASi_x.1 ASi_x.2 ASi_x.3 ASi_x.4 (ASi_xB.1) (ASi_xB.2) (ASi_xB.3) (ASi_xB.4)
Local NonSafety Outputs	ASq_x.1 ASq_x.2 ASq_x.3 ASq_x.4	ASq_x.1 ASq_x.2 ASq_x.3 ASq_x.4	ASq_x.1 ASq_x.2 ASq_x.3 ASq_x.4	ASq_x.1 ASq_x.2 ASq_x.3 (ASq_xB.1) (ASq_xB.2) (ASq_xB.3)

"\_" = Pluto no, "x" = Slave no.

### 7.1.4.5 Combined Transaction A/B slaves

Pluto supports Combined Transaction slaves with 4 inputs and 4 outputs.  
AS-i profile: S-7.A.7

### 7.1.4.6 Analogue input slaves

This is a non-safe slave which reads one analogue input value per channel and then sends a digital representation of this value over the AS-i bus. The slave can have up to 4 input channels and one special function block, "ASiAnalogInput", is needed for each channel.

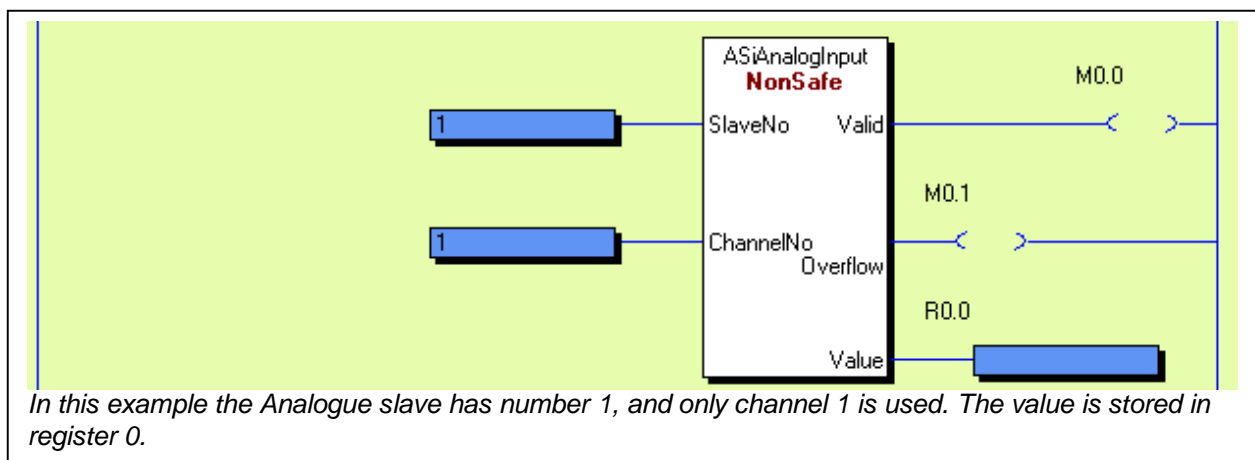

### 7.1.4.7 Analogue output slaves (non-safe)

This is a non-safe slave type with analogue outputs, normally 4-20mA or 0-10V. The slave can have up to 4 output channels. The analogue outputs are controlled with the function block “ASiAnalogOutput”. To the block one register for each channel is connected for setting the output values.

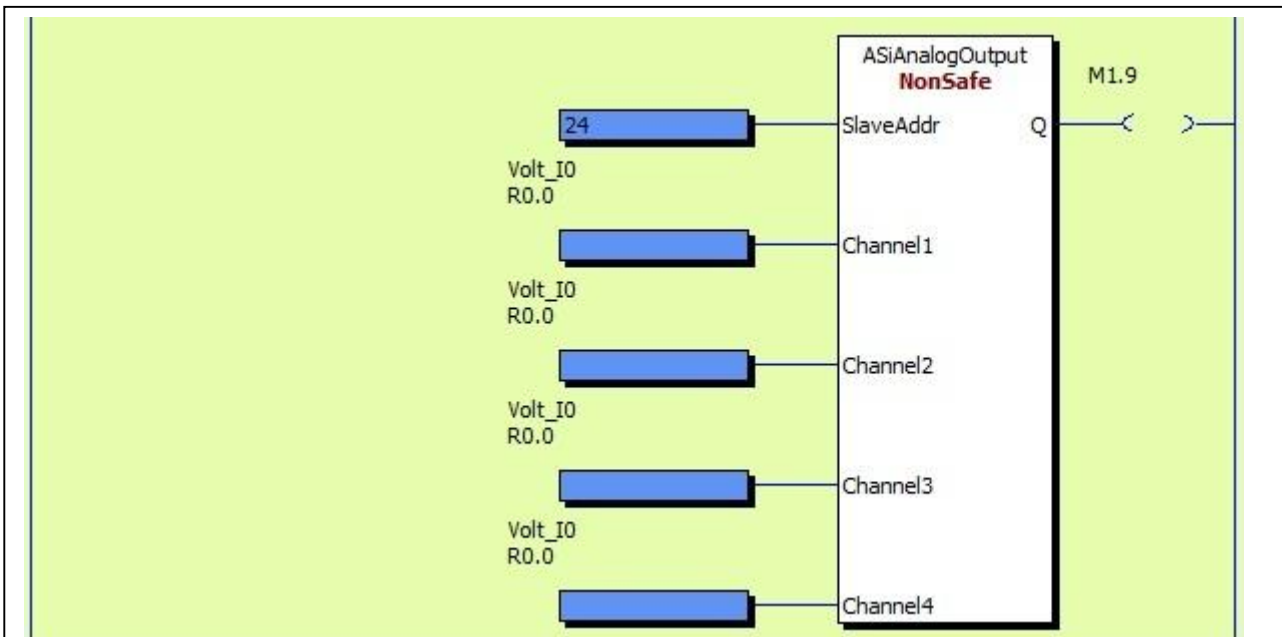

The function block **ASiAnalogOutput** shall be used for analogue output slaves. In this example with an analogue voltage output slave on address 24, all four outputs are set to the value in register R0.0.

### 7.1.4.8 Safe Output

This is a slave with (at this moment) one safe output, and a special function block “ASiSafeOutput1” is needed for the PLC program. This slave is usually combined with a non-safe slave for feedback status. Even if this non-safe slave is included in the same housing as the safe output slave they have different addresses and they are treated as two separate slaves by Pluto. Pluto can handle up to 16 “PlutoAsSafeInput” + “SafeOutput“ slaves.

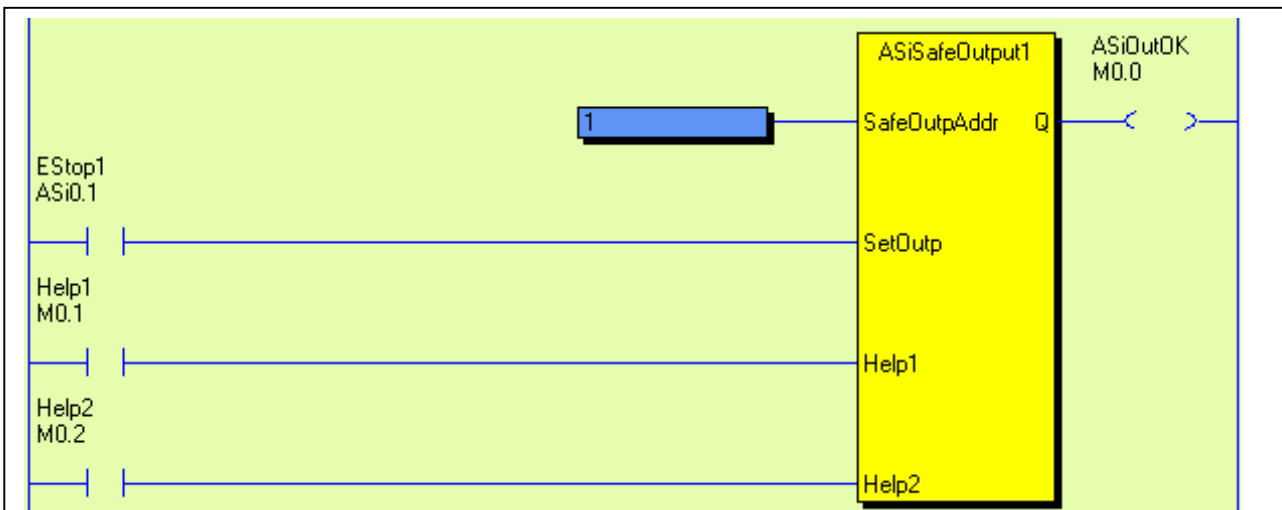

The function block **ASiSafeOutput1** shall be used for slaves with one safe output. *SafeOutputAddr* is the slave address, *SetOutp* sets the safe output and *Help1* and *Help2* are help signals. How the help signals are to be used varies between the different slave manufacturers.

### 7.1.4.9 Pluto as Safe Input

This is the setting for a Pluto that is used as a safe input slave. A special function block, “PlutoAsSafeInput”, is needed for the PLC program. Configuration of the safe input and non-safe outputs are the same as for the ordinary “Safe input” slave described in the table above. Pluto can handle up to 16 “PlutoAsSafeInput” + “SafeOutput” slaves.

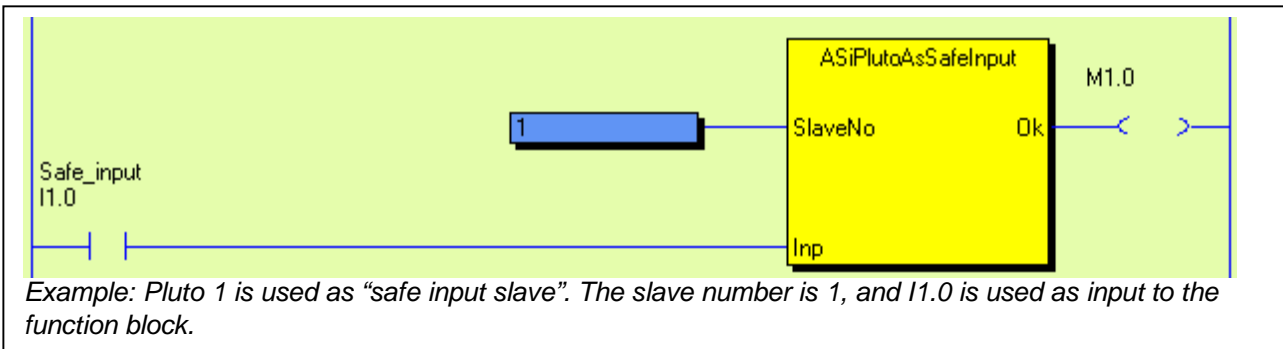

**AS-i slaves**

Slave No	Type of Slave	Model	Param	Profile/ID1	Channel Monitoring
ASi0.1	Safe Input	General	F	S-7.B.F ID1=F	No channel monitoring

Configuration for Pluto 0 which is a master that reads slave no 1.

**AS-i slaves**

Slave No	Type of Slave	Model	Param	Profile/ID1	Channel Monitoring
ASi1.1	Pluto as Safe Input				

Configuration for Pluto 1 which functions as a “Safe input” slave.

### 7.1.5 Write parameter to slave and receive info back

For some AS-i slaves on the market it is possible to send a parameter to the slave and receive info/data back. The function block “ASiParam” is required for this.

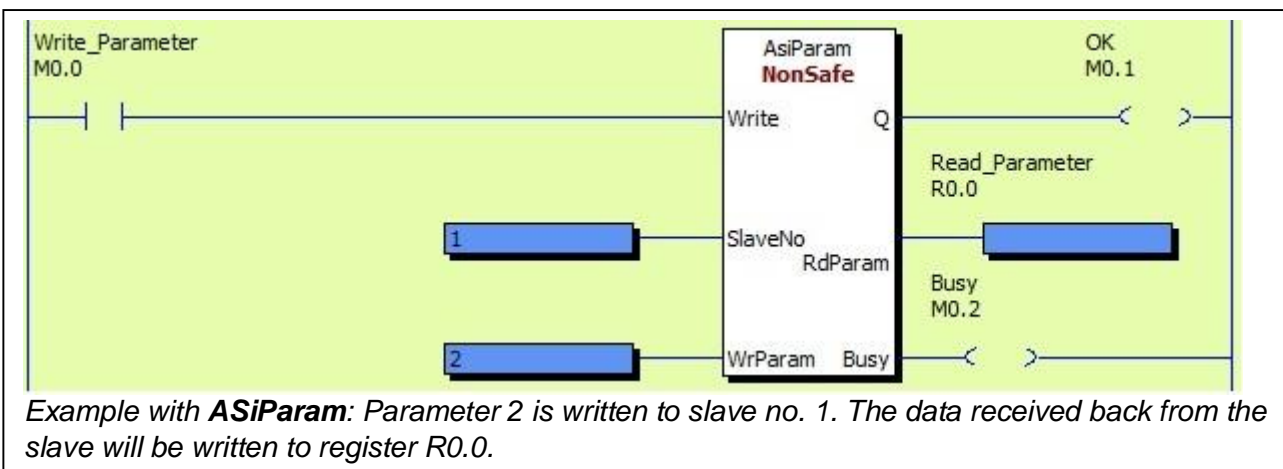

## 7.2 Online configuration of AS-i bus

Before the configuration below can be performed the program has to be compiled and downloaded to the Pluto unit.

The two buttons “Read AS-i slaves” and “Teach safety codes” are semi automatic functions that reads out what kind of slaves that are connected to the AS-i bus.

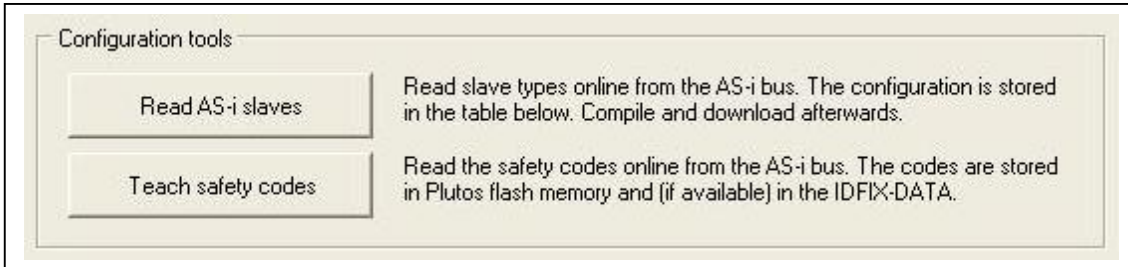

### 7.2.1 Read AS-i slaves

- Start with pressing “Read AS-i slaves”.



Pluto will scan the AS-i bus to find out what type of slaves that are connected to it. The following picture will be displayed.

- If everything looks OK press “Save”

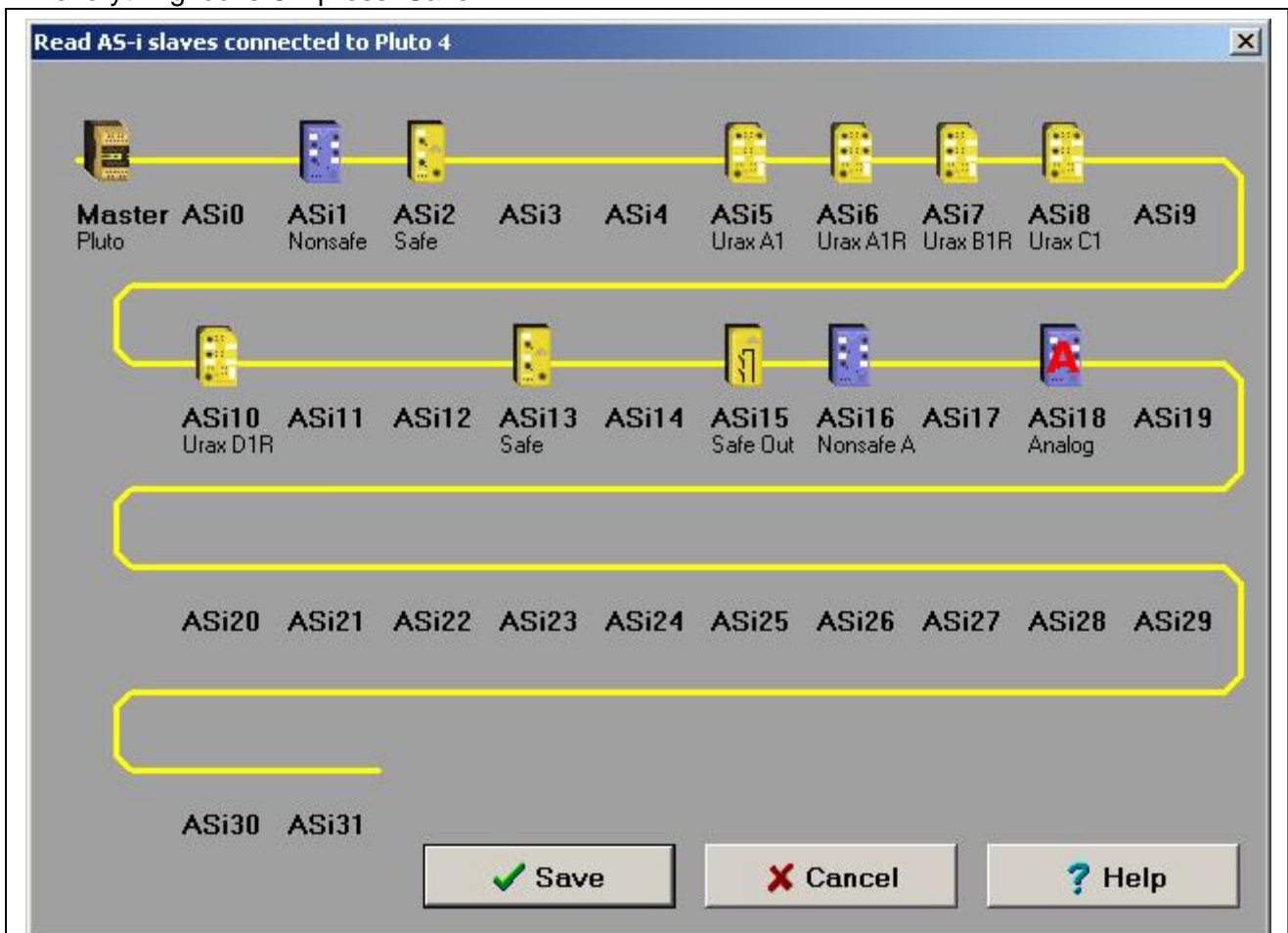

Menu from “Read AS-i slaves”.

In this case Pluto is master on the bus. No: 1 and 16 are standard non- safety slaves, 2 and 13 are safe input slaves, 5..8 and 10 are Urax (safe input) slaves, 15 is a safe output slave, and 18 is an analogue input slave.

## Save

By “Save” the slave profiles (slave types) will be written into the table which is a part of the PLC program. Note that it is only in master mode that the full profile is read and written into the table.

## Storage of slave configuration

The list is stored in the PLC program which means that the configuration must be compiled and downloaded to the Pluto.

### 7.2.1.1 Configuration in Monitor mode

If Pluto is configured as a monitor the configuration procedure is the same, but there are some differences.

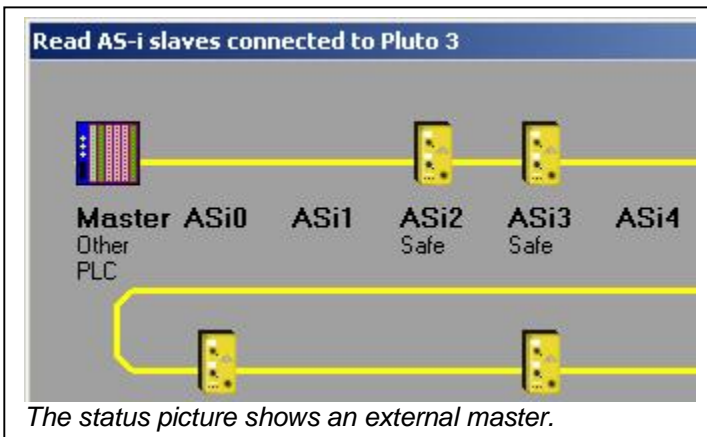

The main difference is that in monitor mode the full slave parameters are not shown. The only information that is shown is if the slaves are safe or non-safe.

AS-i slaves				
	Slave No	Type of Slave	Model	Param Profile/ID1
	ASi1.1	Safe Input		
	ASi1.2	Safe Input		
	ASi1.3	Nonsafe Std		

List with slave types and setting of safety parameters for safe slaves in monitor mode.

## 7.2.2 Teach safety codes

Teaching the safety codes is done with a similar procedure as reading slaves profiles. The teaching of safety codes is a procedure carried out at start-up of the system. The safety codes are not stored in the PLC program so the programmer does not need the information during the programming.

- Press button



A picture over the bus appears. A safety sensor must be activated in order to show the safety code. It is enough that each sensor is activated once during the teach process.

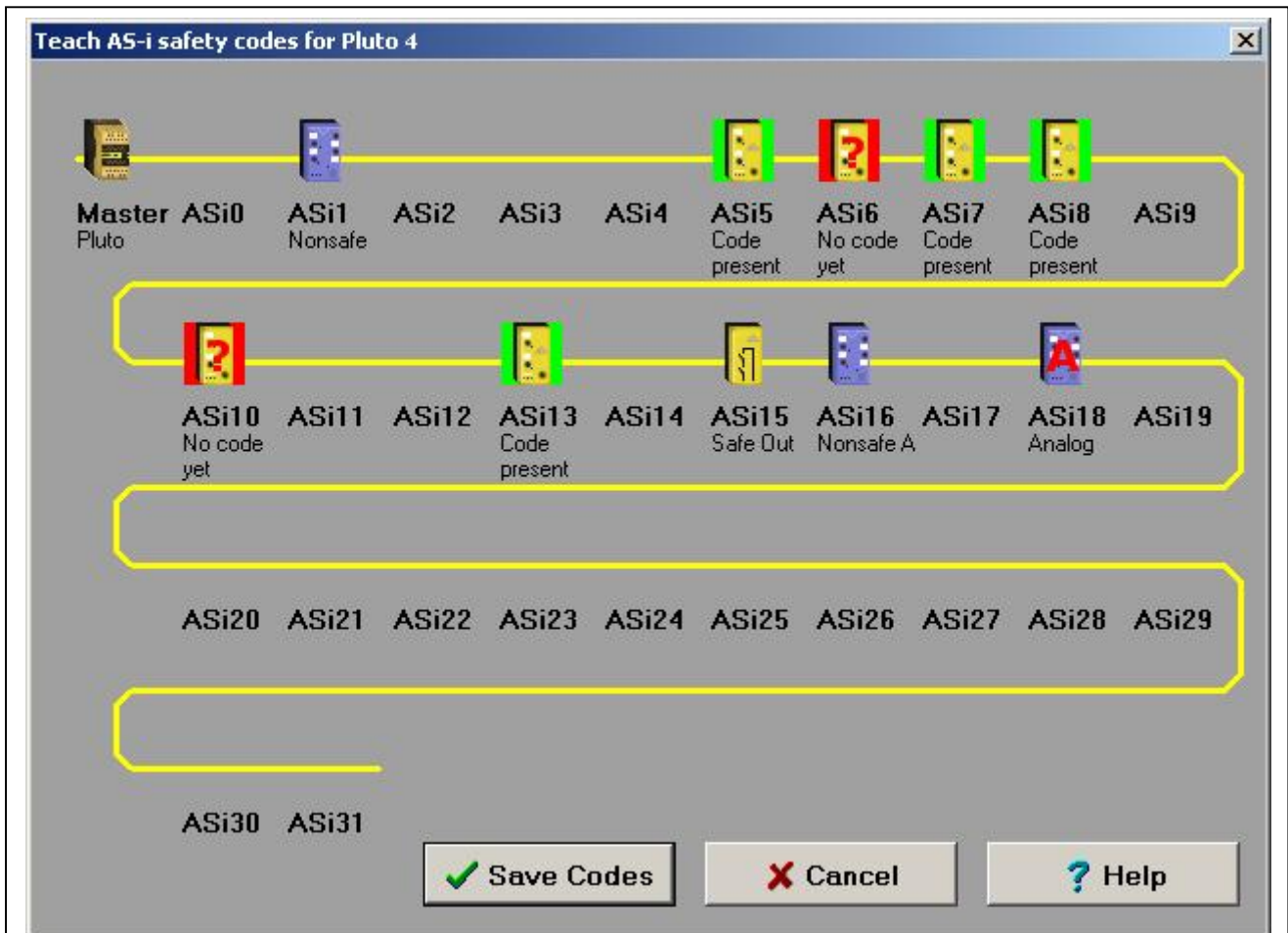

Menu from "Teach safety codes".

Slave no 6 and 10 have not presented any code. Probably they are not activated.

- When all safety codes are available, press "Save codes".

When Pluto saves the codes normal operation has to be stopped. This leads to that Error code Er71 or other system error will be displayed and after about 5 seconds Pluto will automatically reboot.

The codes are stored in two memories, in Pluto and in IDFIX-DATA / IDFIX-PROG if any of these is mounted. (By boot or conflict it is the codes in the IDFIX that will be used. They will in that case be written into the memory in Pluto.)

### 7.2.2.1 Set slave output

Some safety slaves require that certain data output or parameter is set in order for the slave to transmit the safety code. Click “Teach safety codes”, right click on the slave symbol, left click “Set param and Data”, and then select which output to set. When “Code present” is shown, click “Save codes”.

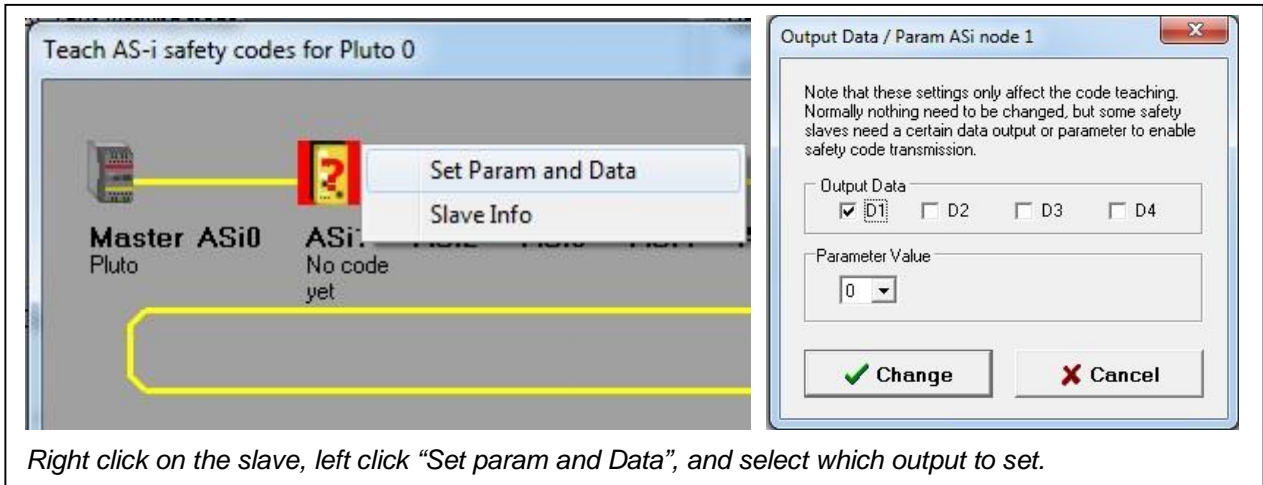

### 7.3 Other online tools

Under Tools à AS-i there are some online tools

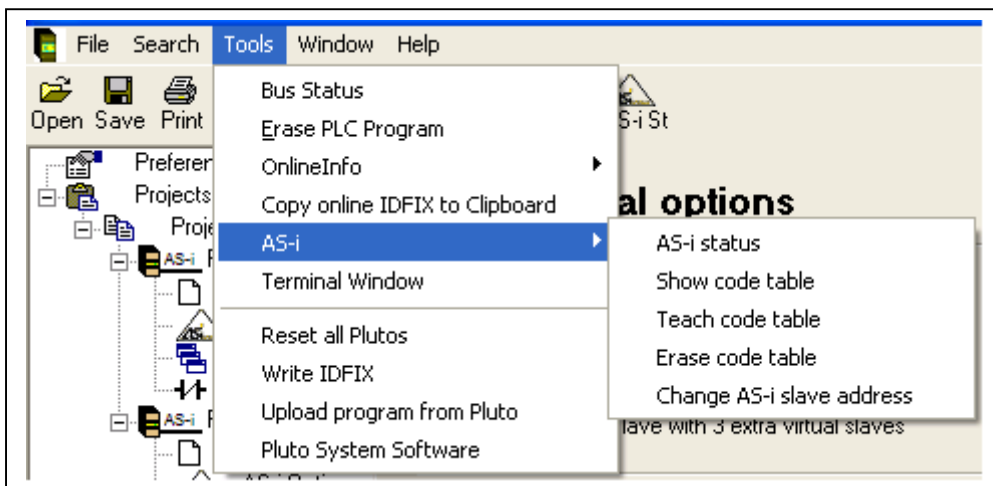



### 7.3.1 AS-i status

AS-i status can be reached either from the list under “Tools” or directly from the main tool bar.

The status picture shows a lot of data about the AS-i bus, slave types, on/off for safety slaves, AS-i cycle time etc.

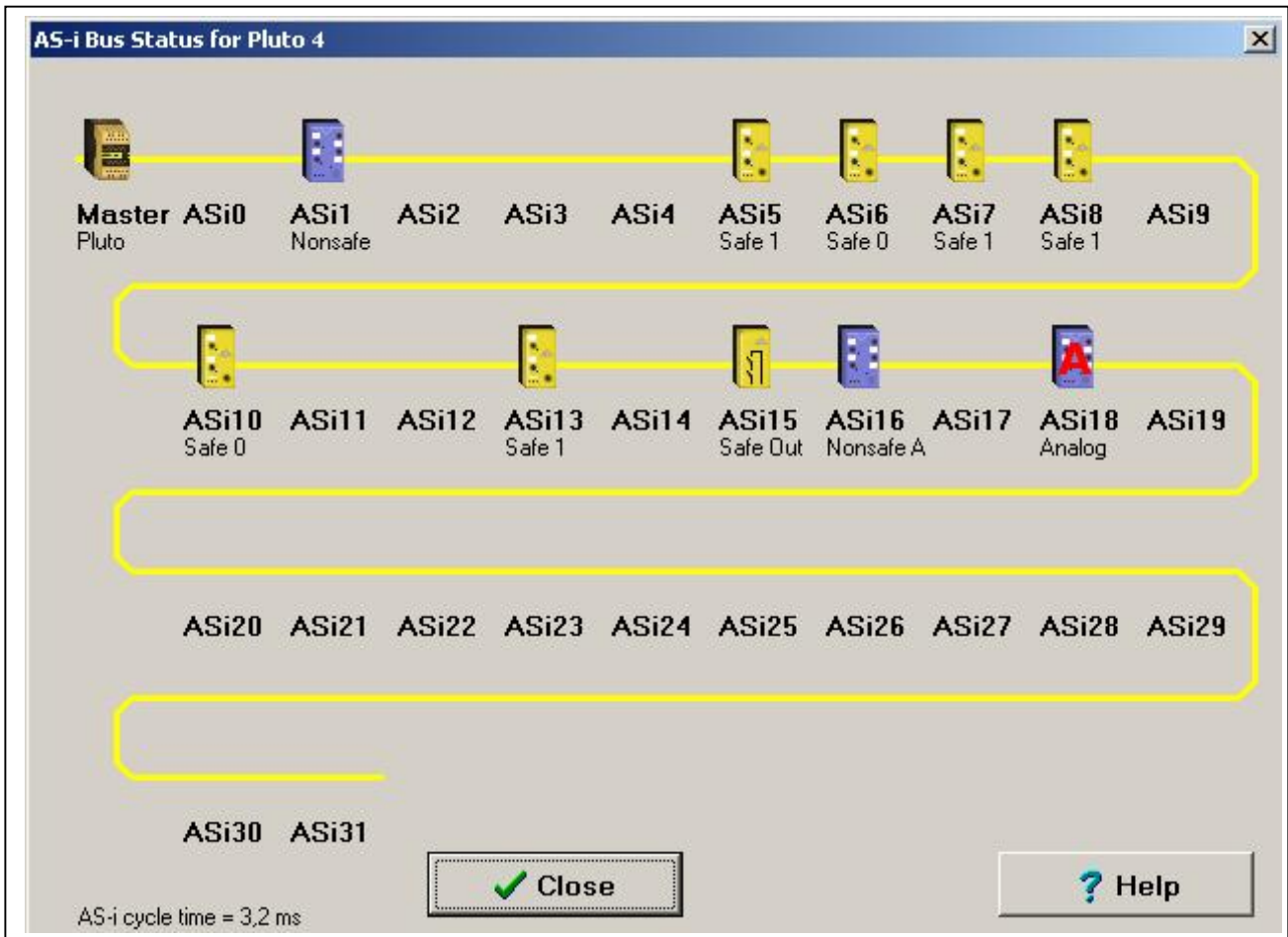
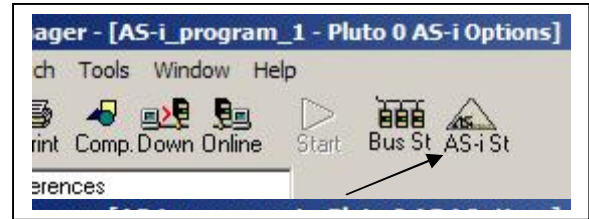

Under "Help" explanation can be found.



*Explanation of symbols in the Status Help picture.*

### 7.3.2 Show code table

All safety codes are shown in a list.

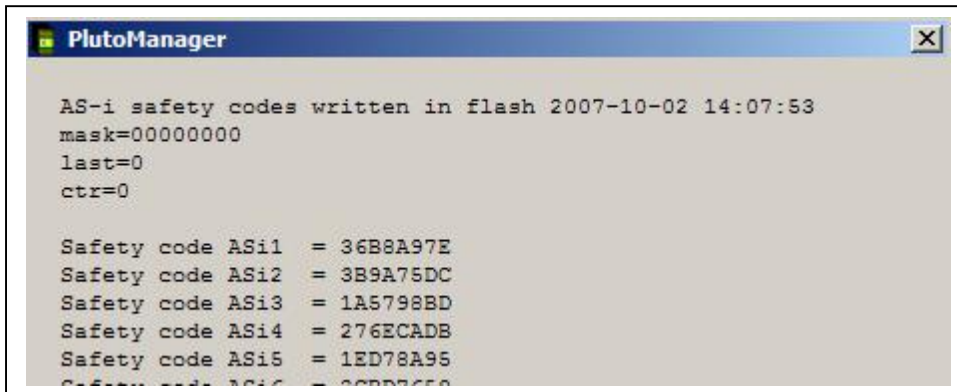

```
PlutoManager
AS-i safety codes written in flash 2007-10-02 14:07:53
mask=00000000
last=0
ctr=0

Safety code ASi1 = 36B8A97E
Safety code ASi2 = 3B9A75DC
Safety code ASi3 = 1A5798BD
Safety code ASi4 = 276ECADB
Safety code ASi5 = 1ED78A95
Safety code ASi6 = 3CDB8650
```

### 7.3.3 Teach code table

The same function as “Teach safety codes” on the page AS-i options.  
(See 7.2.2 above)

### 7.3.4 Erase code table

It is also possible to erase the safety codes from the memory in Pluto and IDFIX-DATA / IDFIX-PROG (if mounted).

Note that the safety codes are not stored in the PLC program which means that if the program is erased the safety codes are still stored.

### 7.3.5 Change address on a slave

Change address of AS-i slave connected to Pluto 4

Master ASi0 ASi1 ASi2 ASi3 ASi4 ASi5 ASi6 ASi7 ASi8 ASi9  
Pluto Nonsafe Safe Safe Safe Safe

ASi10 ASi11 ASi12 ASi13 ASi14 ASi15 ASi16 ASi17 ASi18 ASi19  
Safe Safe Out Nonsafe A Analog

ASi20 ASi25 ASi26 ASi27 ASi28 ASi29

ASi30 ASi31

Right click on slave to change address

Close Help

*Example of address change. Slave 13 is re-addressed to 12*

ASi12 ASi13 ASi14  
Safe

*Result after address change*

## 8 StatusBus

The StatusBus is an information system which makes it possible to identify each slave in the dynamic safety circuit individually, even though up to 30 slaves are connected in series. This can be very helpful for example when troubleshooting, or in a larger facility to find out which slave that has broken the dynamic safety circuit. Each slave, e.g. emergency stop, is numbered from 1 to 30, and addresses may be given via Pluto Manager or with the programming tool ABB FIXA. The slave address is written to, and stored in, the slave itself, while the list of which slaves are included in the network are stored in the Pluto PLC program.

**NOTE! The information via the StatusBus is non-safe, and must not be used for safety evaluation.**

Pluto and Pluto Manager have a number of functions for the StatusBus which are described here.

Depending on how many slaves are available on the StatusBus, there are four different types of telegrams / lengths. With a few number of slaves the update time gets shorter. This is handled automatically by the system.

1-4 slaves (the shortest update time)

1-7 slaves

1-13 slaves

1-30 slaves (the longest update time)

For example when using 5 slaves, to get the shortest possible update time do not select any address higher than 7.

In Pluto, IQ10 – IQ13 can be configured as input for the StatusBus.

Signal	Type of signal	Shape/Level	Options
IQ0.10	StatusBus	Slave no: 1..12	
IQ0.11	Undefined		<input type="checkbox"/> Non_Inv <input type="checkbox"/> No_Filt
IQ0.12	Undefined		<input type="checkbox"/> Non_Inv <input type="checkbox"/> No_Filt
IQ0.13	Output	Static	<input type="checkbox"/> Non_Inv <input type="checkbox"/> No_Filt

StatusBus slaves for IQ0.10

<input checked="" type="checkbox"/> Slave 1	<input checked="" type="checkbox"/> Slave 2	<input checked="" type="checkbox"/> Slave 3	<input checked="" type="checkbox"/> Slave 4	<input checked="" type="checkbox"/> Slave 5	<input checked="" type="checkbox"/> Slave 6	<input checked="" type="checkbox"/> Slave 7	<input checked="" type="checkbox"/> Slave 8	<input checked="" type="checkbox"/> Slave 9	<input checked="" type="checkbox"/> Slave 10
<input checked="" type="checkbox"/> Slave 11	<input checked="" type="checkbox"/> Slave 12	<input type="checkbox"/> Slave 13	<input type="checkbox"/> Slave 14	<input type="checkbox"/> Slave 15	<input type="checkbox"/> Slave 16	<input type="checkbox"/> Slave 17	<input type="checkbox"/> Slave 18	<input type="checkbox"/> Slave 19	<input type="checkbox"/> Slave 20
<input type="checkbox"/> Slave 21	<input type="checkbox"/> Slave 22	<input type="checkbox"/> Slave 23	<input type="checkbox"/> Slave 24	<input type="checkbox"/> Slave 25	<input type="checkbox"/> Slave 26	<input type="checkbox"/> Slave 27	<input type="checkbox"/> Slave 28	<input type="checkbox"/> Slave 29	<input type="checkbox"/> Slave 30

By clicking "Read Slaves" all connected slaves are shown. "Save" will save the configuration to the PLC-program.

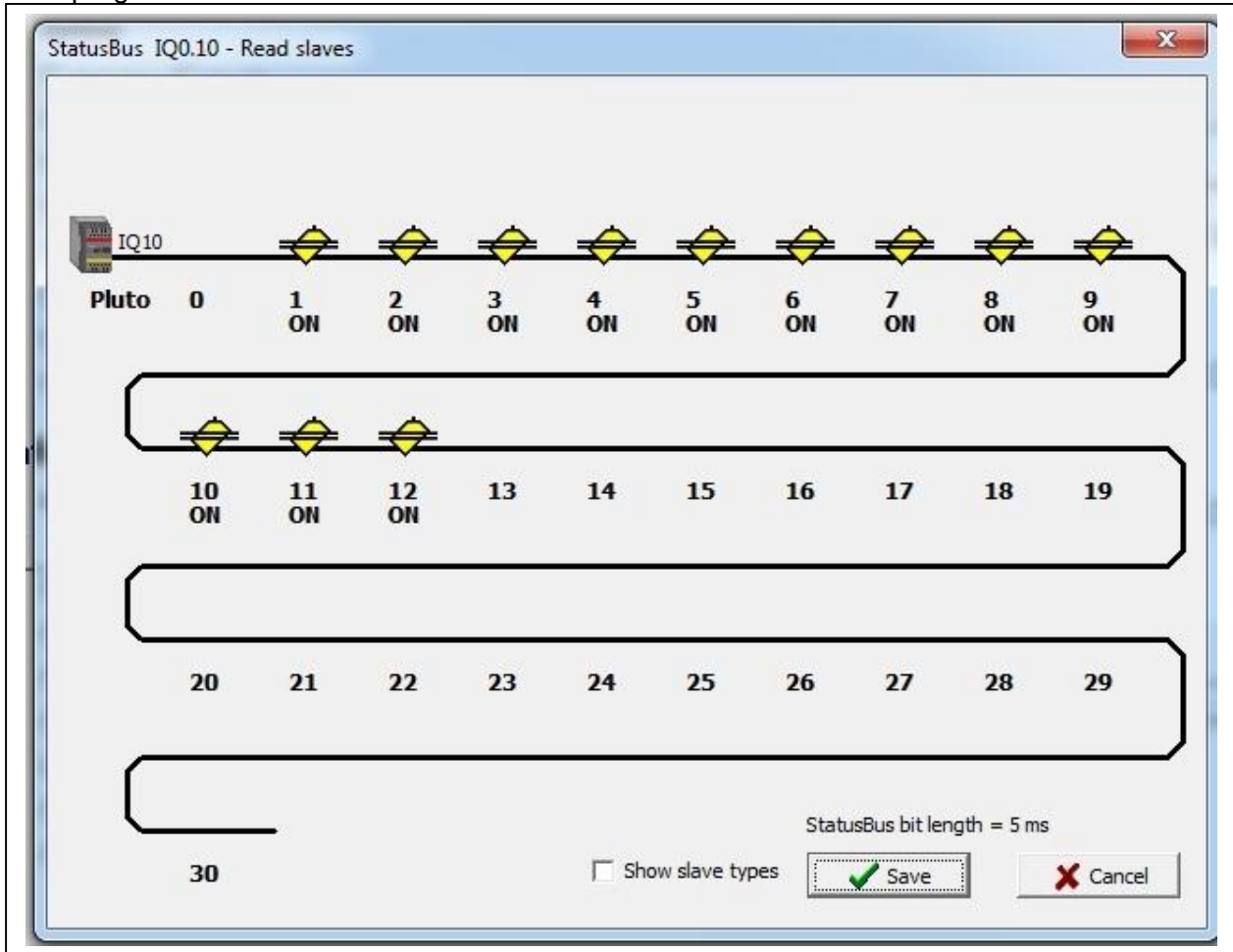

### 8.1 Teach addresses

Each slave on the StatusBus need to be assigned an address. This can be done semi automatically with the Pluto Manager function **Tools/StatusBus/Teach addresses**. The operator can manually reset/switch on one slave after another, and Pluto will give them an address in ascending order. The slaves must first be cleared to address 0, and off/push button pressed before start. First the question "Clear all slave addresses to 0" is shown. By clicking "Yes" all slaves are set to address 0 before "teach address" is started. If "No" is selected, only the slaves already addressed to 0 will be programmed. To program new addresses all slaves must first be turned off (open circuit/push down emergency stop). After that one slave at a time shall be activated according to the instructions on the screen. Pluto Manager suggests the lowest free address in the dropdown list but the operator can change it to another free address.

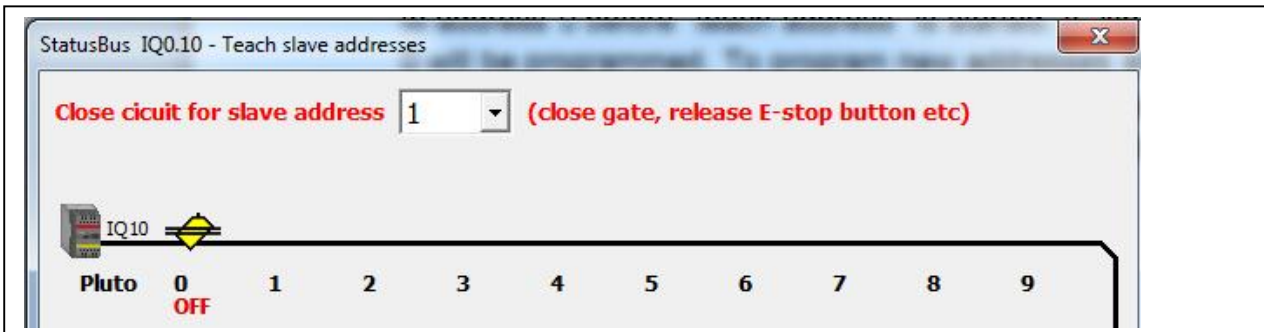



## 8.2 Status

**Status** can be reached either from **Tools/StatusBus/Status**, or directly from the **St Bus** icon in the top menu. **Status** shows all slaves connected to the StatusBus, and if the circuit is open (OFF) or closed (ON). A right click on the slave gives the alternatives **Slave Info** and **Identify Slave**. **Slave Info** gives information about model code, hardware version, software version and serial number. **Identify Slave** fast flashes the light on the slave. This is used to find a certain slave in the facility.

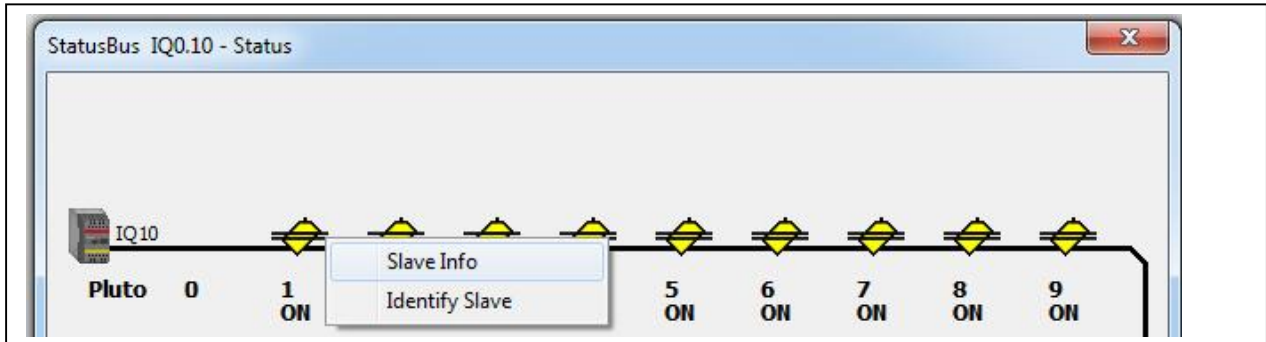

When **Slave Info** is selected the slave icon changes. The icon is different for different slave types. In this example an emergency stop is connected. The icons for all connected slaves will be updated if the box **Show slave type** is checked.

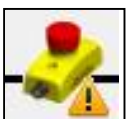
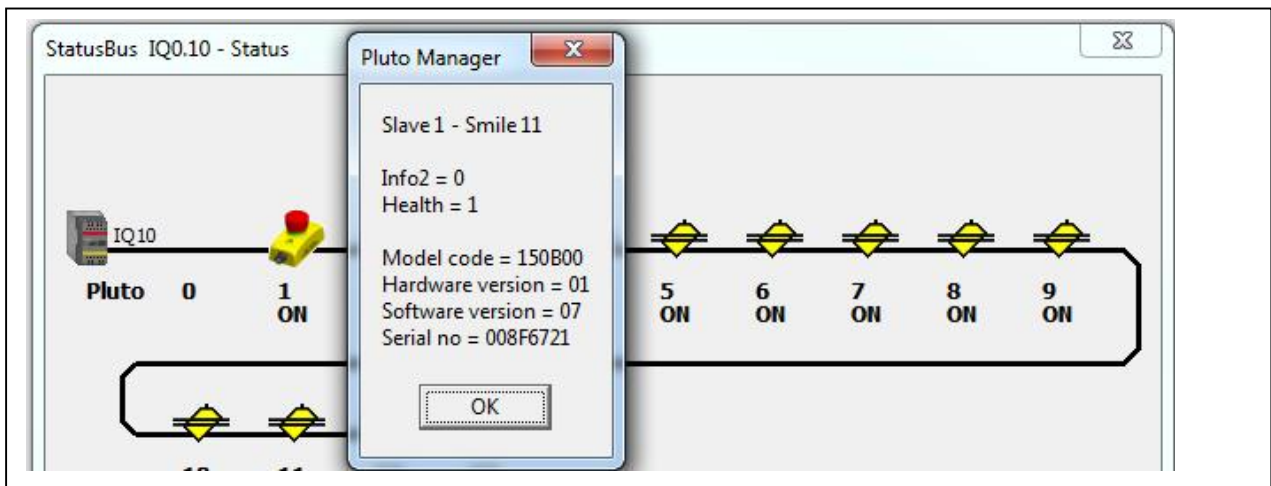

If a warning triangle is shown next to the slave it means that the “healthy bit” in the slave is set to zero. This can have different reasons for different models, but might be supply voltage too low, supply voltage too high, over temperature etc.

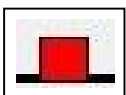

A red square indicates parity error or framing error.



### 8.3 Change slave address

By selecting **Tools/StatusBus/Change slave address**, right click on a slave, and selecting **Change Address**, a new address can be selected for the slave.

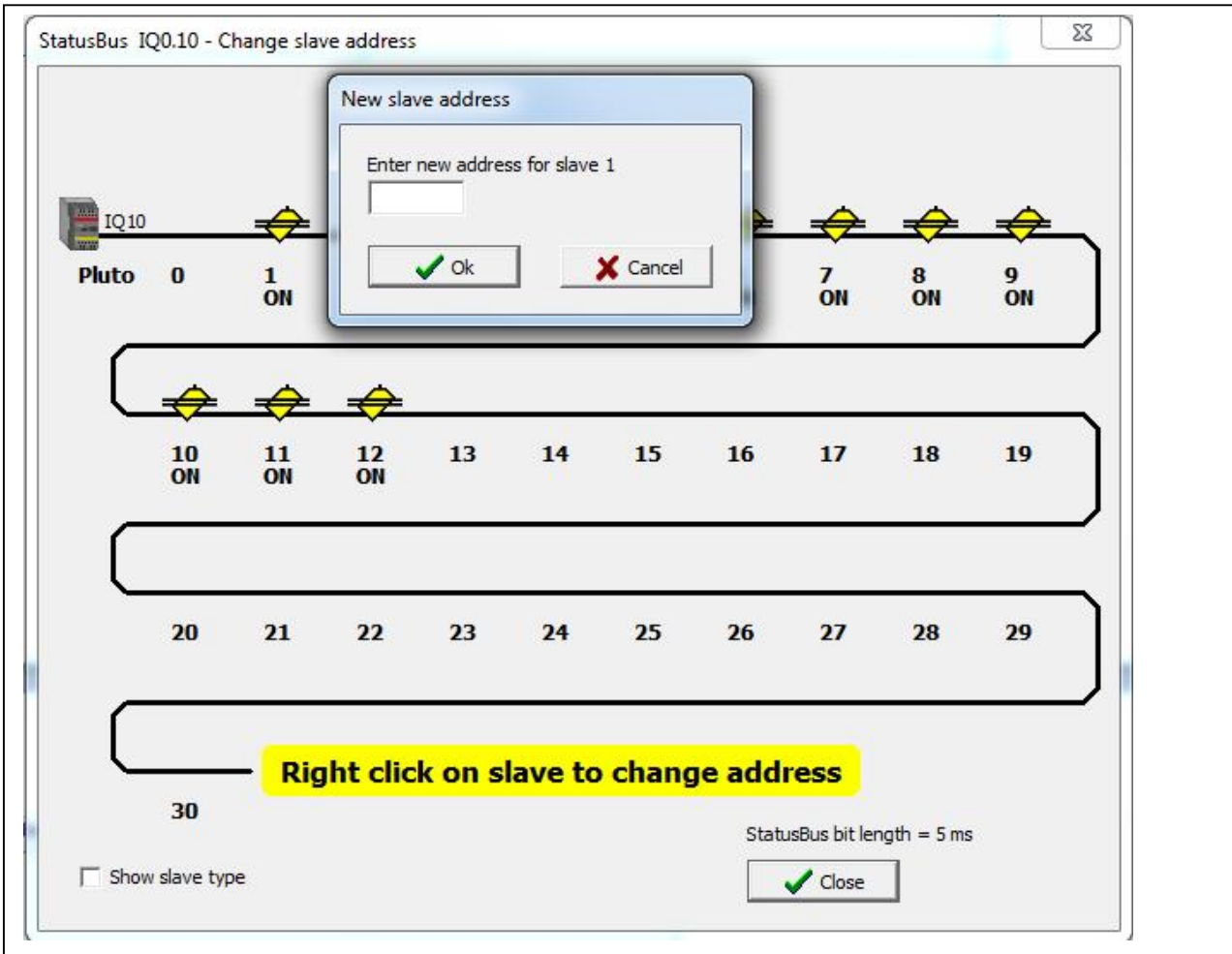

### 8.4 Exchange of slave/Automatic addressing

It is possible to replace a slave from the net, and the new slave will automatically be assigned the same address as the one it replaces. The requirements are:

- All configured slaves are present.
- Only one slave at a time can be replaced.
- The new slave must have address set to 0. (This is the case for new unused slaves.)
- The new slave shall be in open-circuit state (emergency stop pressed down).

Procedure:

- Remove the slave which shall be replaced.
- Connect the new slave.

## 8.5 StatusBus – Function blocks

A function block is needed to read the StatusBus. The function blocks described below are all included in the “func05” library.

### StatusBusOn1 / StatusBusOn2

Since each block handles 15 slaves, both StatusBusOn1 and StatusBusOn2 must be used if the number of slaves exceeds 15.

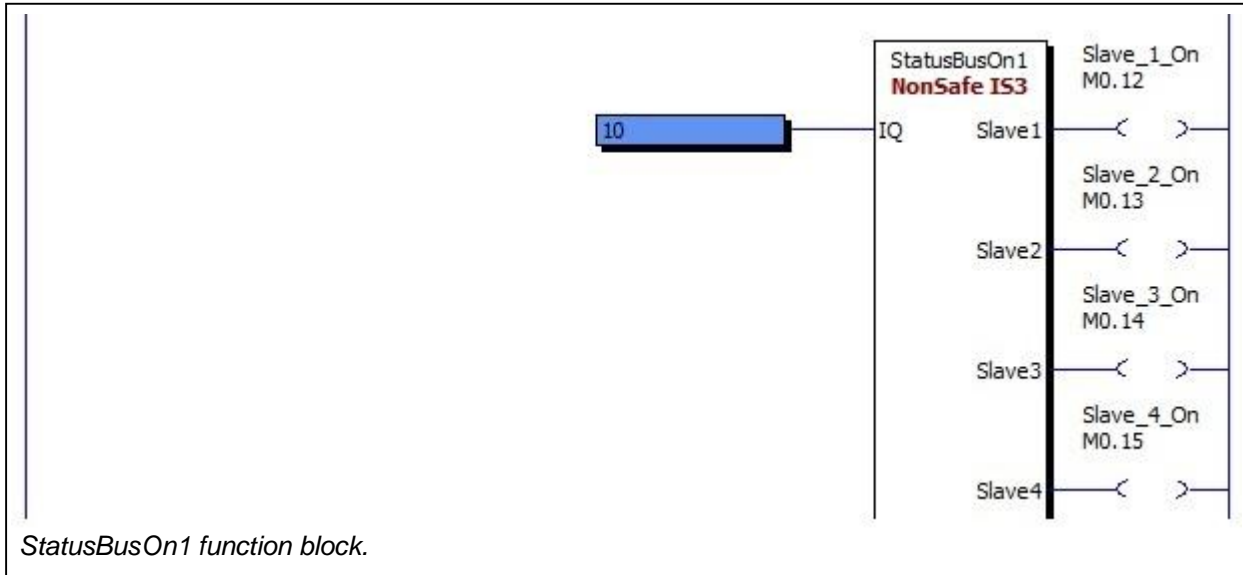

StatusBusOn1 function block. Description of inputs and outputs:	
IQ	Constant for selection of StatusBus IQ.
Slave1	Set if StatusBus slave 1 is ON.
Slave2	Set if StatusBus slave 2 is ON.
:	:
Slave15	Set if StatusBus slave 15 is ON.

### StatusBusOnReg

Similar to StatusBusOn1 / StatusBusOn2 except that the output is a register value.

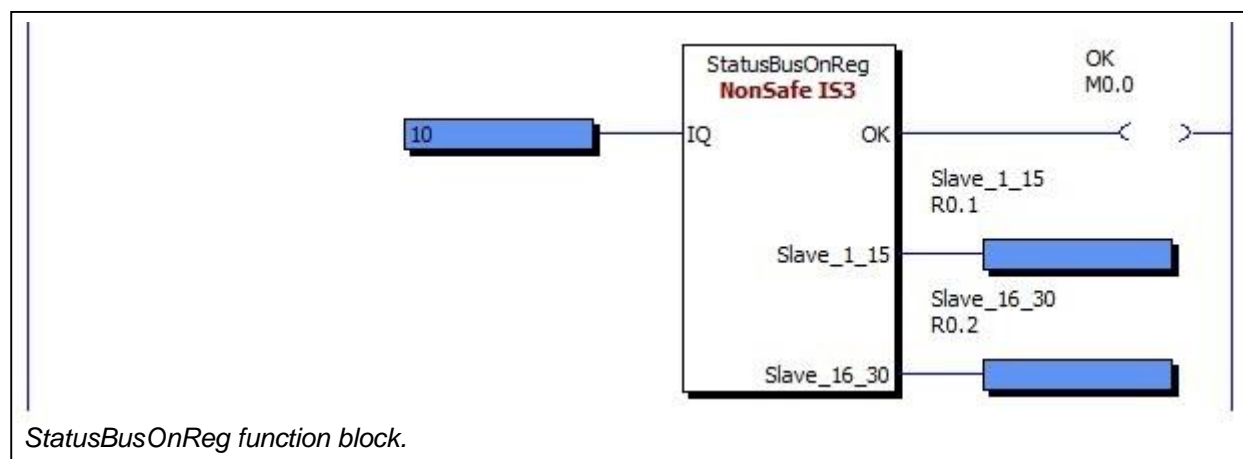

StatusBusOnReg function block. Description of inputs and outputs:	
IQ	Constant for selection of StatusBus IQ.
OK	Always set.
Slave_1_15	Register value set if slave 1...15 is ON. One bit/value.
Slave_16_30	Register value set if slave 16...30 is ON. One bit/value.

## StatusBusSlave

This block, one per slave, give additional information about the slave status.

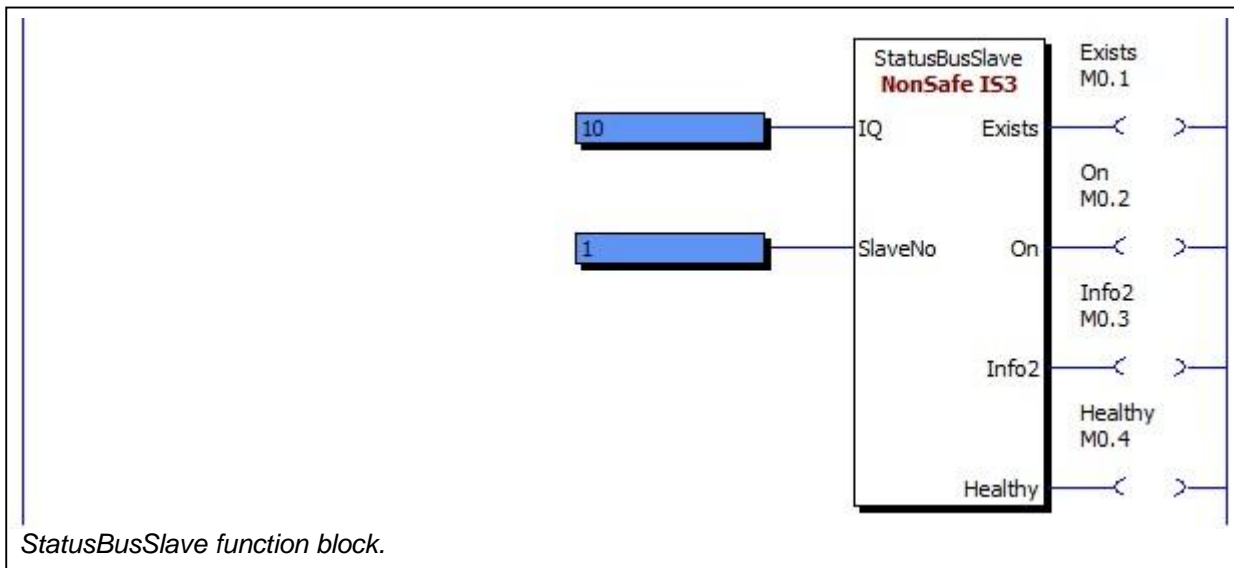

StatusBusSlave function block. Description of inputs and outputs:	
IQ	Constant for selection of StatusBus IQ.
SlaveNo	Number of the slave, 1-30.
Exists	Slave is present in the system and communicates on StatusBus.
On	Set when the slave safety is ON.
Info2	Auxiliary info.
Healthy	No problem for slave.

## 9 Analogue inputs Pluto D20 and D45 – Function blocks

Pluto D20 is equipped with 4, and Pluto D45 with 8, safe 4-20mA/0-10V analogue inputs. These inputs (D20: IA0 - IA3, D45: IA0 – IA7) can be configured in Pluto Manager as either “ordinary” failsafe inputs, as analogue inputs 0-10V or as analogue inputs 4-20mA.

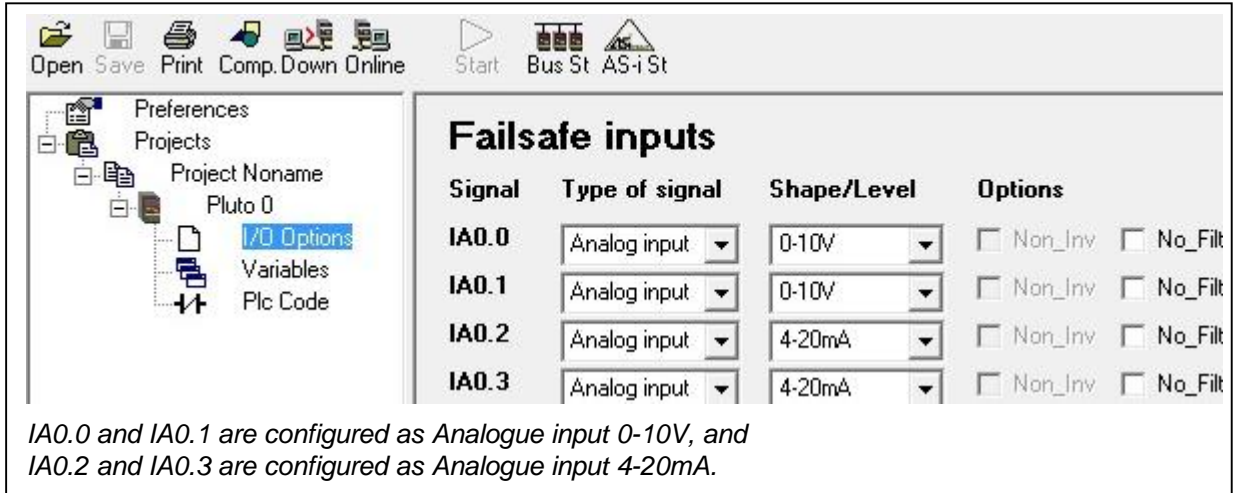

Signal	Type of signal	Shape/Level	Options	
IA0.0	Analog input	0-10V	<input type="checkbox"/> Non_Inv	<input type="checkbox"/> No_Filt
IA0.1	Analog input	0-10V	<input type="checkbox"/> Non_Inv	<input type="checkbox"/> No_Filt
IA0.2	Analog input	4-20mA	<input type="checkbox"/> Non_Inv	<input type="checkbox"/> No_Filt
IA0.3	Analog input	4-20mA	<input type="checkbox"/> Non_Inv	<input type="checkbox"/> No_Filt

*IA0.0 and IA0.1 are configured as Analogue input 0-10V, and IA0.2 and IA0.3 are configured as Analogue input 4-20mA.*

For analogue input 0-10V the function block “ReadVoltage” is needed, and for analogue input 4-20mA the function block “ReadCurrent” is needed. Both of these function blocks are included in the “Analog01.fps” library. Included are also 32-bit versions of the function blocks (“ReadVoltage\_32” and “ReadCurrent\_32”) for use with Double Registers.

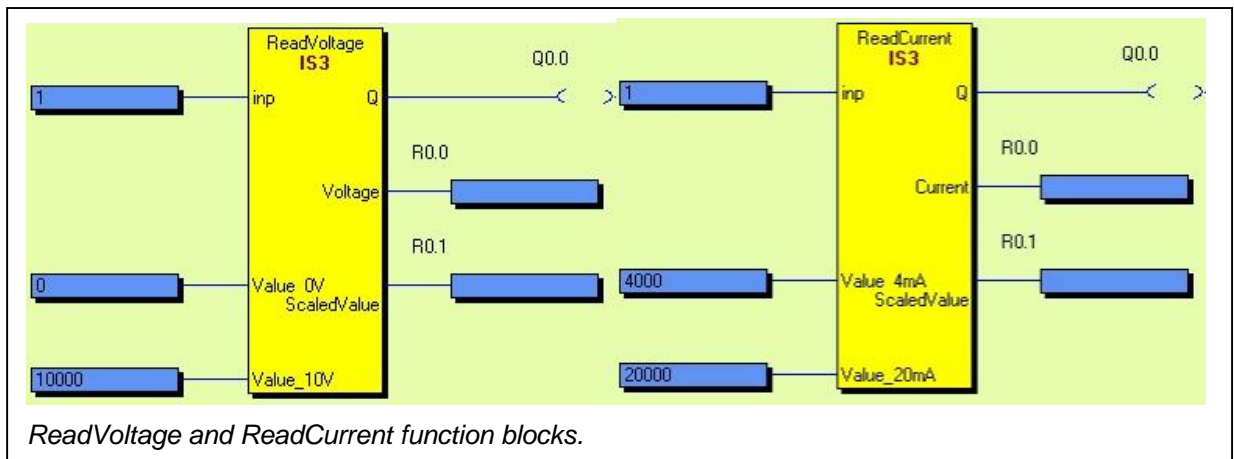

<b>ReadVoltage</b> function block. Description of inputs and outputs:	
Input	Input connected to the block.
Value 0V	Input value for scaling. At 0V the output "Scaled value" will show this value.
Value 10V	Input value for scaling. At 10V the output "Scaled value" will show this value.
Q	OK output. Value is within range.
Voltage	Output with calibrated absolute value in mV.
Scaled Value	Output with scaled value.

<b>ReadCurrent</b> function block. Description of inputs and outputs:	
Input	Input connected to the block.
Value 4mA	Input value for scaling. At 4mA the output "Scaled value" will show this value.
Value 20mA	Input value for scaling. At 20mA the output "Scaled value" will show this value.
Q	OK output. Value is within range.
Current	Output with calibrated absolute value in $\mu$ A.
Scaled Value	Output with scaled value.

**Note:** For an application to reach SIL 3/PL e two sensors in parallel, with one analogue input and one function block each, must be used.

## 9.1 Application example with two sensors – Temperature measurement

With the application example below, using two different sensors, Category 4/PL e can be achieved.

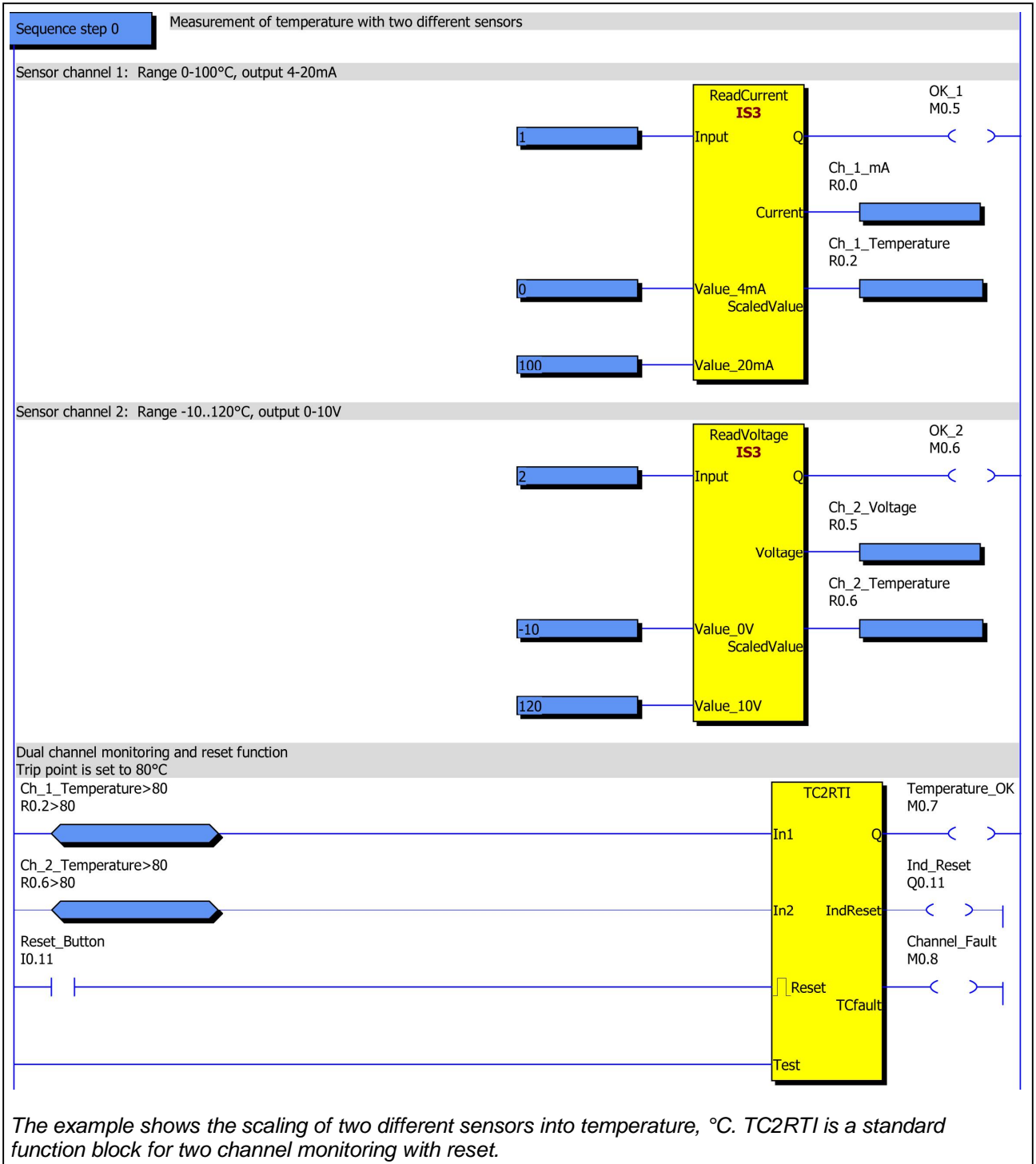
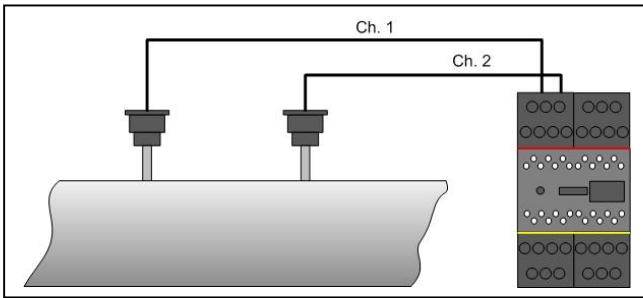

## 10 Counter inputs Pluto D45

For Pluto D45 the inputs IA0 – IA3 can be configured as counter inputs (pulse counting) which work for frequencies up to 14000 Hz. As counter inputs IA0 – IA3 can be used in two ways, Up counting or Up/Down counting. This is described further in the Pluto Hardware Manual. The inputs shall be configured in Pluto Manager.

Signal	Type of signal	Shape/Level	Options	
IA0.0	Counter input	Up	<input type="checkbox"/> Non_Inv	<input type="checkbox"/> No_Filt
IA0.1	Undefined	Up	<input type="checkbox"/> Non_Inv	<input type="checkbox"/> No_Filt
IA0.2	Undefined	Up/Down	<input type="checkbox"/> Non_Inv	<input type="checkbox"/> No_Filt

*Configuration of counter input.*

For counter inputs configured as “Up” counting the function block “HS\_SpeedCount\_Up” shall be used.

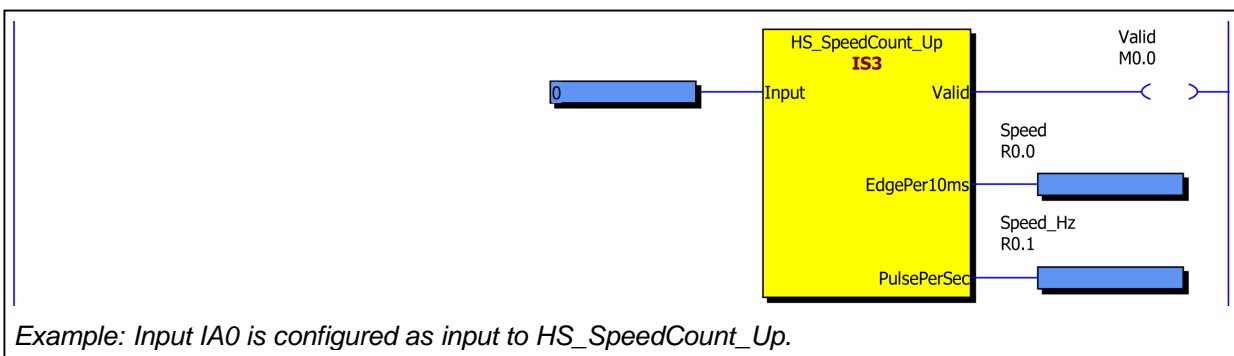

HS_SpeedCount_Up function block. Description of inputs and outputs:	
Input	Input connected to the block.
Valid	OK output. Value is within range.
EdgePer10ms*	Output speed in edges per 10 ms. Shall be connected to a register (R).
PulsePerSec*	Output speed in Hz. Shall be connected to a register (R).

\*Both outputs refer to the same speed, only the scaling differs.

For counter inputs configured as “Up/Down” counting the function block “HS\_SpeedCount\_Dir” shall be used.

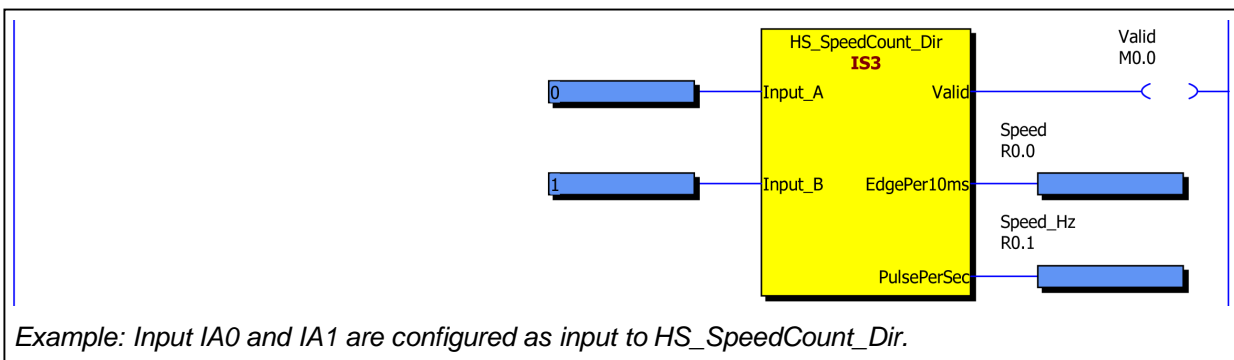

HS_SpeedCount_Dir function block. Description of inputs and outputs:	
Input_A	Input A connected to the block.
Input_B	Input B connected to the block.
Valid	OK output. Value is within range.
EdgePer10ms	Output speed in edges per 10 ms. Shall be connected to a register (R).
PulsePerSec	Output speed in Hz. Shall be connected to a register (R).

\*Both outputs refer to the same speed, only the scaling differs.



For speed monitoring and stand still monitoring the function block “SpeedMon1” can be used. The two inputs for speed can take their values from different sources such as the function blocks for incremental encoders, absolute encoders, analogue inputs etc.

The function block has three safety functions:

- Compares a register “Speed” with a second register for speed “CompSpeed”, and checks that the difference is not more than the value set at the input register “MaxDiff”. If the difference is within the limit the output “SpeedValid” is set, and the output “ValidSpeed” will be equal to “Speed”. The timer input "DiffDelay" is an off-delay for the comparison. The block allows the two values “Speed” and “CompSpeed” to differ more than MaxDiff during this time.
- Stand still monitoring of input "Speed" with hysteresis. The output "StandStill" is set when the value at the input "Speed" has been 0 for 0.7 sec. After that the "Speed" value is allowed to increase/decrease three times in either direction.
- Safe limit speed (SLS). The output SafeLowSpeed is set when the input value at "Speed" is less than the input value "LowSpeedLim".

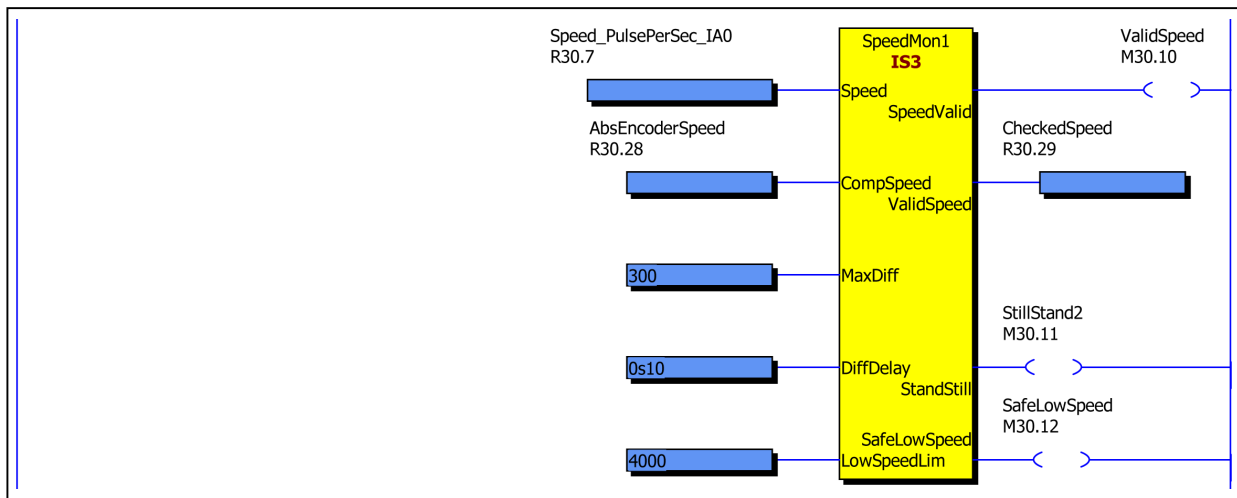

SpeedMon1 function block. Description of inputs and outputs:	
Speed	Input register for speed value (Primary speed input).
CompSpeed	Input register for monitoring of the value in the primary “Speed” input.
MaxDiff	Input for the maximum allowed difference between “Speed” and “CompSpeed”.
DiffDelay	Off-delay for the comparison. MaxDiff can be exceeded during this time.
LowSpeedLim	Limit value for safe low speed.
Speed/Valid	Output for when the two speed values are within the limit of “MaxDiff”.
Valid/Speed	Normally equal to the input “Speed”. At fault 32767.
StandStill	Output set at standstill.
SafeLowSpeed	Output set when speed is less than input “LowSpeedLim”.

## 10.1 Application with two encoders – Speed monitoring

With the application example below, using two incremental encoders, Category 4/PL e can be achieved for speed monitoring and “safe low speed” function. For “stand still” monitoring Category 3/PL d can be achieved if motion is detected regularly. Note that faults such as wire break not will be detected during stand still, so stand still should not be longer than a few hours each time.

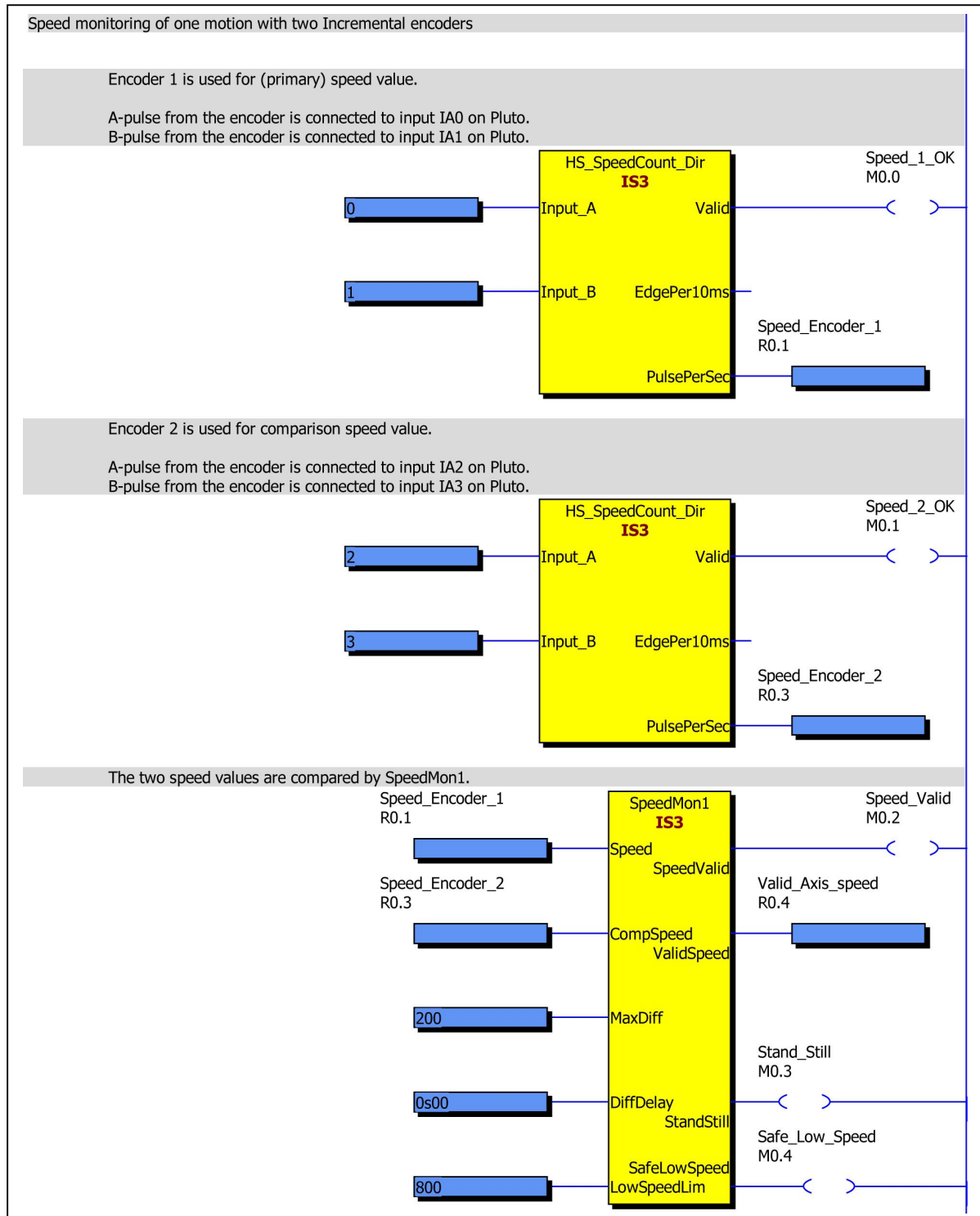
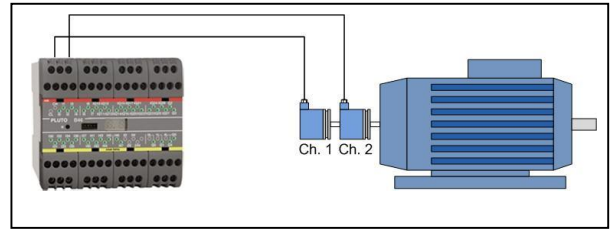

## 10.2 Application with one encoder and one analogue value – Speed monitoring

With the application example below, using one encoder and one analogue value from a frequency converter, Category 3/PL d can be achieved for speed monitoring, “safe low speed” function and “stand still” monitoring. For stand still monitoring it is required that motion is detected regularly.

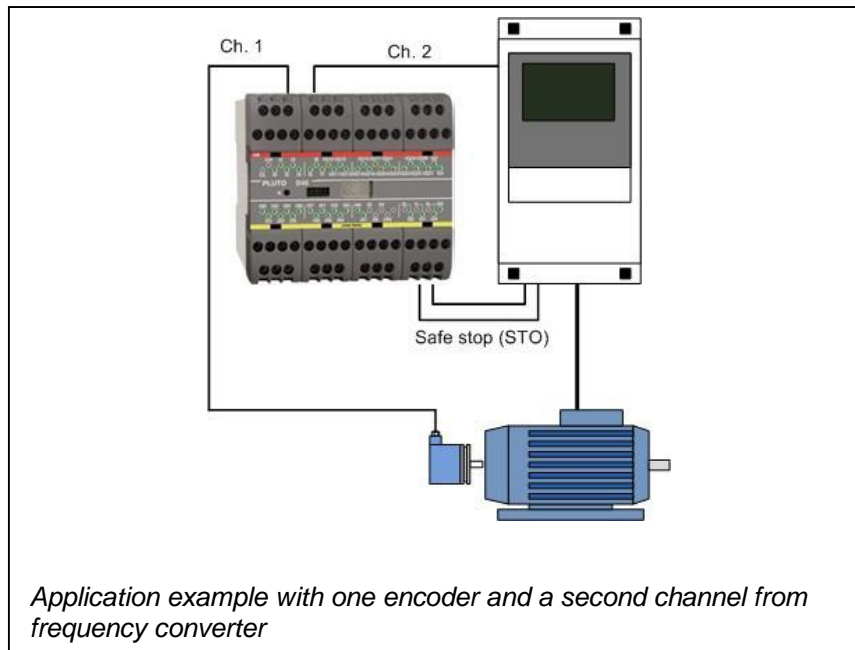

Note that faults such as wire break in encoder cable not will be detected during stand still, so stand still should not be longer than a few hours each time. However wire break in the analogue channel is detected since 4 mA is defined as 0 speed. Wire break will result in 0 mA and Speed\_Freq\_Conv = -122. The block SpeedMon1 will detect the fault.

Example with speed monitoring of one motion with one photocell and an analogue signal from a frequency converter

The photocell gives 20 pulses/revolution  
 When the frequency converter gives maximum, the speed is 24.4 revolutions per second and the analogue output gives 20mA.  
 At that speed the photocell frequency is  $24.4 \times 20 = 488$  pulses/sec

The photocell is connected to input IA0 on Pluto.

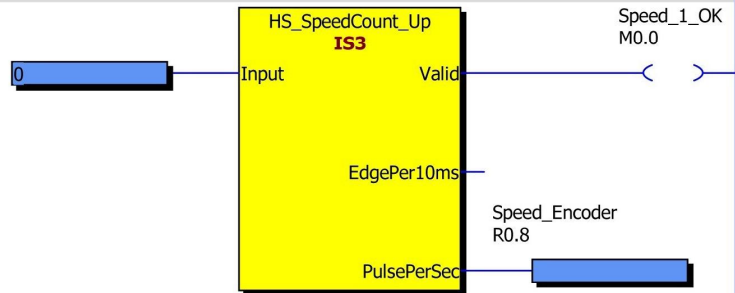

Analogue output from frequency converter is connected to input IA1 on Pluto.  
 The analogue input value from the frequency converter is scaled to 488 at 20mA to match the encoder value.

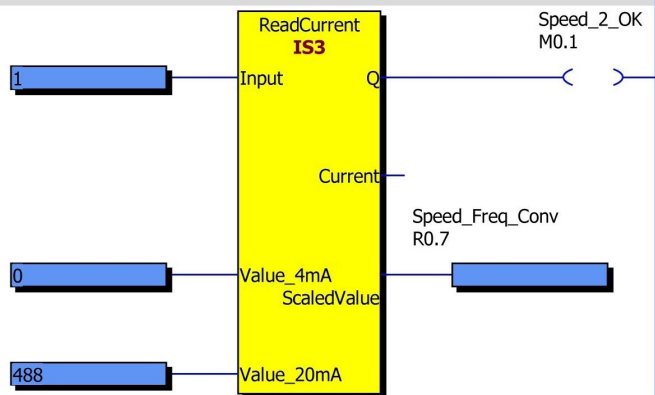

The two speed values are compared by SpeedMon1.  
 The photocell is used for (primary) speed value.  
 Analogue value from the frequency converter is used for comparison of the photocell speed value.

The value from the frequency converter is allowed to differ 20 (MaxDiff) however during 0.5 sec (DiffDelay) it is allowed to differ more than 20. After that SpeedValid switches off and ValidSpeed is set to 32767.  
 StandStill is initiated when Speed and ValidSpeed is 0. (CompSpeed does not need to be 0, but within MaxDiff)  
 The output SafeLowSpeed is on when the Speed and ValidSpeed is below 150.

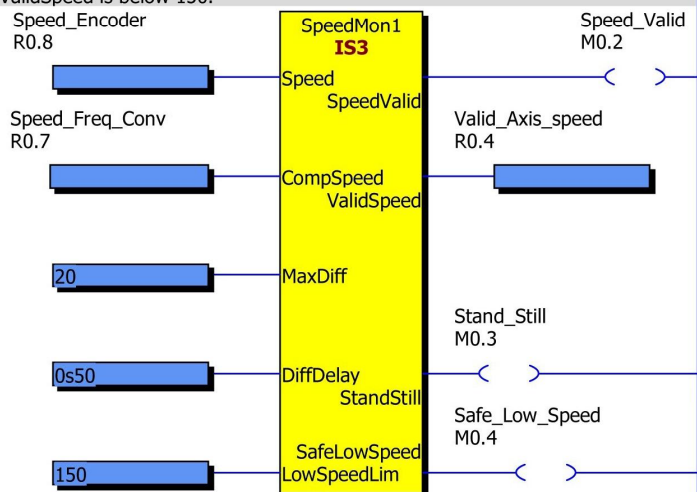

Program example for speed monitoring with one encoder and one analogue channel.

# 11 Variables

By a mouse click on “Variables” in the tree menu, pages for each type of variable can be reached. Here it is possible to give an individual name and description for each of the variables.

## 11.1.1 Symbolic Name

A variable can be given a name which can be used instead of the real I/O name further on at the ladder logic programming. The naming can be left out or be filled in later.

The following characters are allowed for variable names:

- A – Z, a – z and all other letters according to the Unicode specification (for example Scandinavian, Greek, Russian and Chinese letters).
- 0 - 9, but not as the first character.
- \_ (Underscore) is allowed, but not as the first character.
- . (Dot) is allowed with Instruction set 2, but not with Instruction set 3.

## 11.1.2 Description

The description has no influence on other functions.

## 11.2 Local/Global variables

At the top of the page there are tabs representing each kind of variable type. The variables can be either Global or Local. Global variables can be used by all Pluto units connected to the bus, local variables are just for internal use in one Pluto unit. Global variables are marked (G).

The screenshot shows a software interface with a tree view on the left containing 'Preferences', 'Projects', 'Project Project3', 'Pluto 0', 'I/O Options', 'Variables', and 'Plc Code'. The main area displays 'Variable attributes: [G] Global variable. These variables are visible to other Plutos on the bus.' Below this are tabs for 'Safety Inputs', 'Safety Outputs', 'NonSafety Outputs', 'Global Memories', 'Memories', 'Registers', 'System Memories', and 'System Registers'. A table is shown with the following data:

Status	Variable	Symbolic Name	Description
	I0.0	[G] MuteSensor1	Sensor for initiation of muting. MuteSensor1 and MuteSensor2
	I0.1	[G] MuteSensor2	Sensor for initiation of muting. MuteSensor1 and MuteSensor2
	I0.2	[G] ContMonitor	NC contacts of contactors for monitoring

Var. type/Family	A20 family (except B22 and D20), O2
	Global variables:
Safety Inputs	I_.0...7, 10...17
Safety Outputs	Q_.0 ...Q_.3
Global Memories	GM_.0 ... GM_.11
	Local variables:
Safety Inputs	-
NonSafety Inputs	-
Safety Outputs	-
NonSafety Outputs	Q_.10 ...Q_.17
Memories	M_.0 ... M_.599
Registers	R_.0 ..149
Double Registers**	DR_.0...DR_.148 (only even numbers)
System Memories	SM_.0 ..199
System Registers	SR_.0 ..99

\*\*With instruction set 3 only. One Double Register consists of two subsequent Registers. See Part 2 of this manual.

Var. type/Family	Pluto B22
	Global variables:
Safety Inputs	I_0...7, 10...17
Safety Outputs	-
Global Memories	GM_0 ... GM_11
	Local variables:
Safety Inputs	I_20...I_25
NonSafety Inputs	-
Safety Outputs	-
NonSafety Outputs	Q_10 ...Q_17
Memories	M_0 ... M_599
Registers	R_0 ..149
Double Registers**	DR_0...DR_148 (only even numbers)
System Memories	SM_0 ..199
System Registers	SR_0 ..99

\*\*With instruction set 3 only. One Double Register consists of two subsequent Registers. See Part 2 of this manual.

Var. type/Family	Pluto D20
	Global variables:
Safety Inputs	IA_0...IA_3, I_4...I_7, I_10... I_17
Safety Outputs	Q_0 ...Q_3
Global Memories	GM_0 ... GM_11
	Local variables:
Safety Inputs	-
NonSafety Inputs	-
Safety Outputs	-
NonSafety Outputs	Q_10 ...Q_17
Memories	M_0 ... M_599
Registers	R_0 ..149
Double Registers**	DR_0...DR_148 (only even numbers)
System Memories	SM_0 ..199
System Registers	SR_0 ..99

\*\*With instruction set 3 only. One Double Register consists of two subsequent Registers. See Part 2 of this manual.

Var. type/Family	Pluto B46, S46
	Global variables:
Safety Inputs	I_0...7, 10...17
Safety Outputs	Q_0 ...Q_3
Global Memories	GM_0 ... GM_11
	Local variables:
Safety Inputs	I_20..27, 30..37, 40..47
NonSafety Inputs	-
Safety Outputs	Q_4...Q_5
NonSafety Outputs	Q_10 ...17, 20..27
Memories	M_0 ... M_599
Registers	R_0 ..149
Double Registers**	DR_0...DR_148 (only even numbers)
System Memories	SM_0 ..199
System Registers	SR_0 ..99

\*\*With instruction set 3 only. One Double Register consists of two subsequent Registers. See Part 2 of this manual.

Var. type/Family	Pluto D45
	Global variables:
Safety Inputs	IA_0...IA_7, I_10...I_17
Safety Outputs	Q_0 ...Q_3
Global Memories	GM_0 ... GM_11
	Local variables:
Safety Inputs	I_20..26, 30..37, 40..47
NonSafety Inputs	-
Safety Outputs	Q_4...Q_5
NonSafety Outputs	Q_10 ...17, 20..26
Memories	M_0 ... M_599
Registers	R_0 ..149
Double Registers**	DR_0...DR_148 (only even numbers)
System Memories	SM_0 ..199
System Registers	SR_0 ..99

\*\*With instruction set 3 only. One Double Register consists of two subsequent Registers. See Part 2 of this manual.

Var. type/Family	Pluto AS-i
	Global variables:
Safety Inputs	I_0 and ASi_1...15
Safety Outputs	Q_0 ...Q_3
Global Memories	GM_0 ... GM_11
	Local variables:
Safety Inputs	I_1..3, 10..13 and ASi_16..31
NonSafety Inputs	Slave Inputs: ASi_X.Y*
Safety Outputs	-
NonSafety Outputs	Q_10..13 and Slave Outputs: ASq_X.Y*
Memories	M_0 ... M_149 (With instruction set 2) M_0 ... M_599 (With instruction set 3)
Registers	R_0 ..149
Double Registers**	DR_0...DR_148 (only even numbers)
System Memories	SM_0 ..199
System Registers	SR_0 ..99

\*\*With instruction set 3 only. One Double Register consists of two subsequent Registers. See Part 2 of this manual.

Var. type/Family	Pluto B42 AS-i
	Global variables:
Safety Inputs	I_0...3
Safety Outputs	-
Global Memories	GM_0 ... GM_27
	Local variables:
Safety Inputs	I_10..17, 20..27, 30..37, 40..47 and ASi_1..31
NonSafety Inputs	Slave Inputs: ASi_X.Y*
Safety Outputs	Q_0...Q_5
NonSafety Outputs	Q_10 ...17, 20..27 and Slave Outputs: ASq_X.Y*
Memories	M_0 ... M_599
Registers	R_0 ..149
Double Registers**	DR_0...DR_148 (only even numbers)
System Memories	SM_0 ..199
System Registers	SR_0 ..99

\*X = 1...31 (1B...31B), Y = 1...4

If for instance ASi\_1 (ASi\_1.1...ASi\_1.4) is a Nonsafe Std slave with 4 inputs, there can not also be an ASi\_1B. But if ASi\_1 is an A/B slave (Nonsafe A) there can also be an ASi\_1B (Nonsafe B).

\*\*With instruction set 3 only. One Double Register consists of two subsequent Registers. See Part 2 of this manual.



## 11.2.1 Export variables

For Pluto with “Instruction set 3” and OS version 3.2 or later it is possible to select a number of local variables (Registers, Double Registers, Memories, Safety Outputs, NonSafety Outputs and/or Safety Inputs) and export them to make them available for the other Pluto units on the bus. Right-click on the Variable in Pluto manager, and then left click to select the variable name in the pop-up menu.

Variable attributes: **[G]** Global variable. Variable is visible to other Plutos on the bus.  
**[E]** Exported Variable. Variable is visible to other Plutos on the bus.

Status	Variable	Symbolic Name	Description
	M0.0		
	M0.1		
	M0.2		
	M0.3		

[E] Export M0.3

Selection of “Export” variables will add telegrams to the Pluto bus communication and there is a limit to the amount of “Export” variables which can be added.

Each of the following options equals one extra telegram-pair:

- 32 boolean variables
- 16 boolean variables + 1 register
- 2 registers
- 1 Double Register

A maximum of 4 extra telegram-pairs per Pluto, but a total maximum of 16 extra telegram-pairs per project is allowed. There are also some important drawbacks:

- The bus load increases considerably, especially if rapidly updated registers are used (e.g. encoder or analogue values) since a combination of cyclic and change-of-state transmissions are being used.
- For registers and double registers, maximum stop time is increased 10ms compared to Boolean variables.
- Since the mapping of “Export” variables is done by the compiler the variables can only be accessed from Plutos within the same project.
- “Export” variables cannot be used in gateways.

In the PLC program the variables can be used directly, as soon as they are exported. Two special function blocks, "RegisterValid" and "DRegisterValid", can be used to find out if an exported register or double register is valid. Normally this is not needed, but if a zero value is used to enable a dangerous function these blocks must be used since the value zero also can mean "no communication". A typical case is a still-stand monitor when stand-still is represented by the value 0:

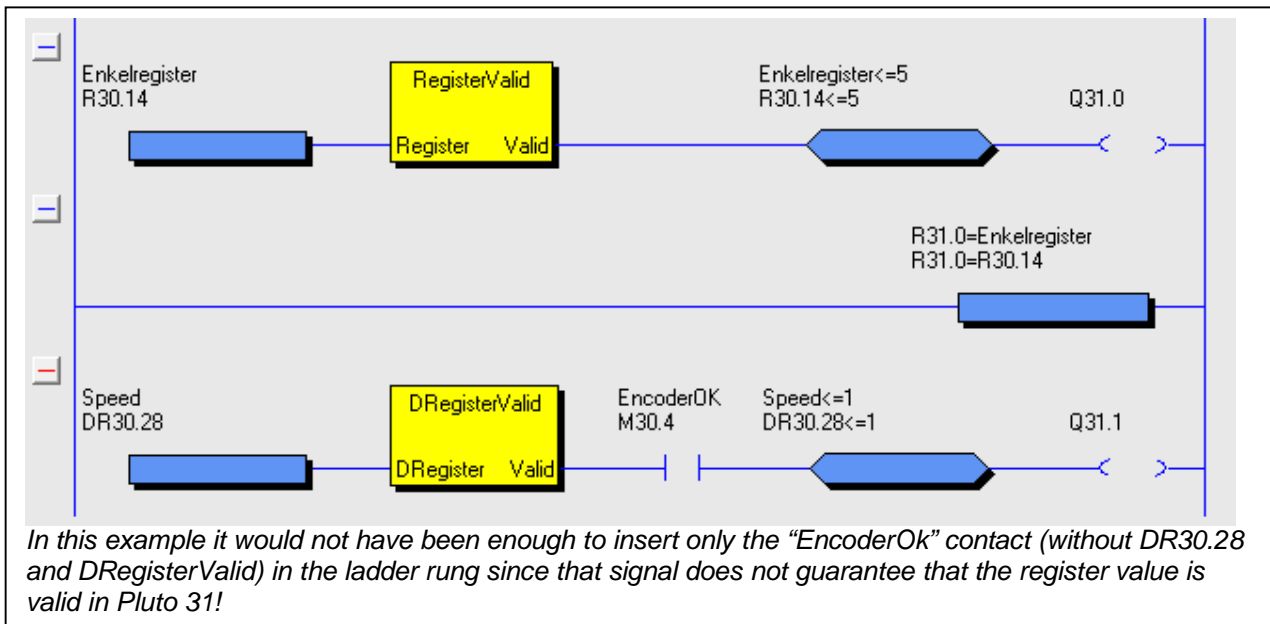

### 11.3 Remanent variables

A remanent variable implies that the stored value remains even when the power to Pluto has been switched off. This function is only implemented in the following Pluto types with hardware (HW) version and operating system (OS) version according to the table below:

Pluto type	HW version	OS version
A20 v2	All	All
B20 v2	All	All
S20 v2	All	All
B22	All	All
D20	All	All
B46 v2	2.11 or higher	3.0 or higher
S46 v2	2.11 or higher	3.0 or higher
D45	All	All
AS-i v2	3.7 or higher	3.0 or higher
B42 AS-i	All	All

For Pluto HW version, see label on Pluto. If no HW version is stated, the Pluto is too old to have remanent variables.



To configure remanent variables, click on the button “Remanent Variables”.

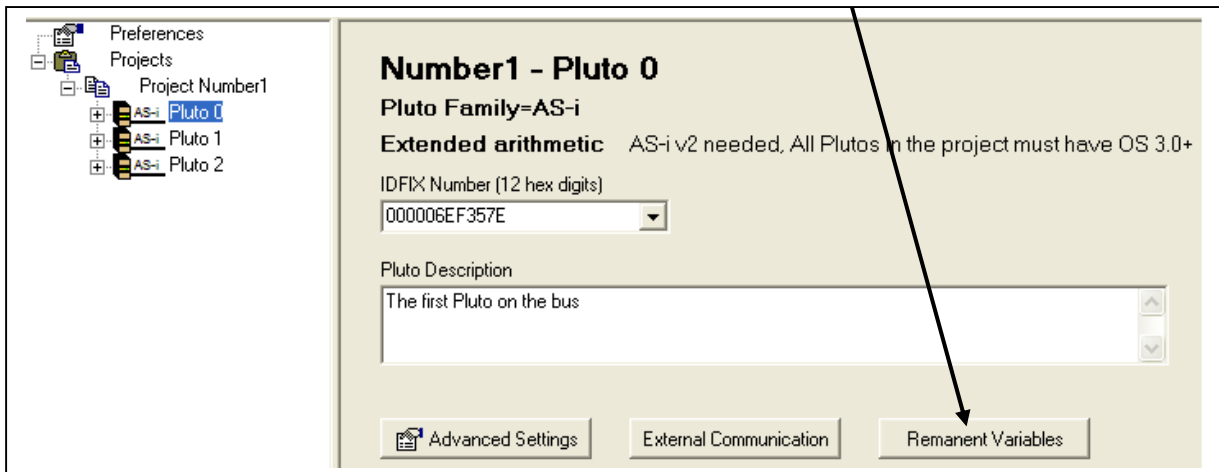

Registers R100 to R131 and/or Memories M100 to M131 can be used as remanent variables in different combinations. The only exception is that if all Remanent Registers (R100..R131) has been selected, then no Remanent Memories can be selected.

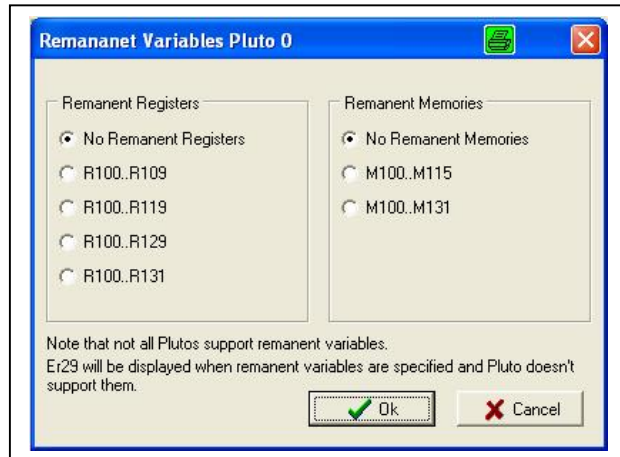

In the variable list, Memories and Registers which has been configured as remanent are marked with a red [R].

Double Registers		System Memories			
Safety Inputs		Nonsafety Inputs	Safety Outputs	NonSafety Outputs	Global Mem
Status	Variable	Symbolic Name	Description		
	MO.100 [R]				
	MO.101 [R]				
	MO.102 [R]				
	MO.103 [R]				

### 11.3.1 Clear Remanent variables

At download of the PLC program from a PC to Pluto the user is given the choice to either clear or keep the remanent variable values.

However, if the project name or the station number (Pluto number) has been changed the variables will be cleared at download even if "Keep remanent variable values" has been selected.

At Er74 (Remanent memory error) the variables will also be cleared.

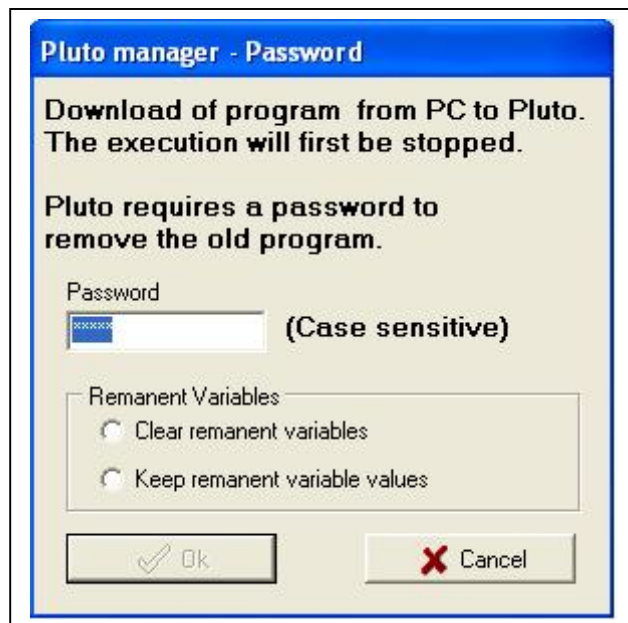

## 11.4 Export and import variable names

By right clicking on “Variables” in the tree menu to the left the variable names can be imported from, or exported to, a .csv file which can be read by e.g. Excel.

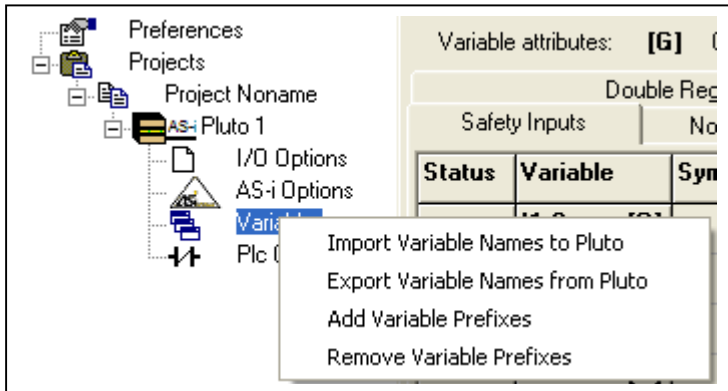

By clicking “Import Variable Names to Pluto” the following dialog box is shown. Select desired alternative for prefixes and click “Import” to import selected file.

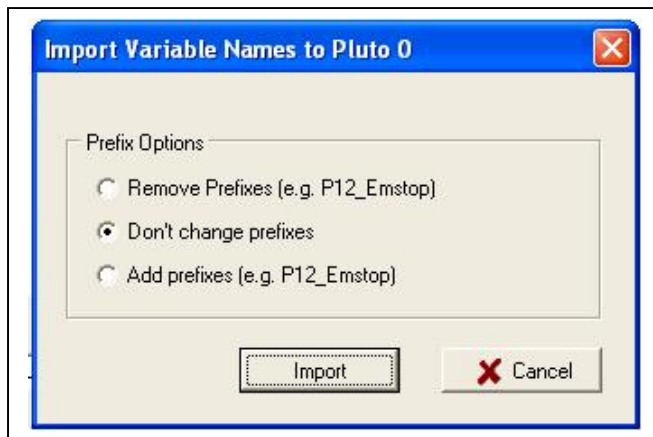

By clicking “Export Variable Names from Pluto” the following dialog box is shown. Select desired alternative for Global/Local variables, prefixes and sorting order. Click “Export” to create the file.

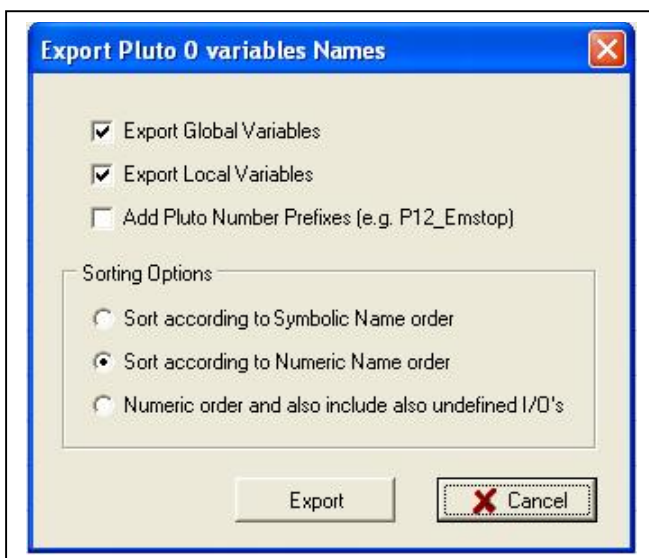

# 12 Ladder logic programming

By a mouse click on "PLC Code" in the tree menu the page for ladder logic programming is shown.

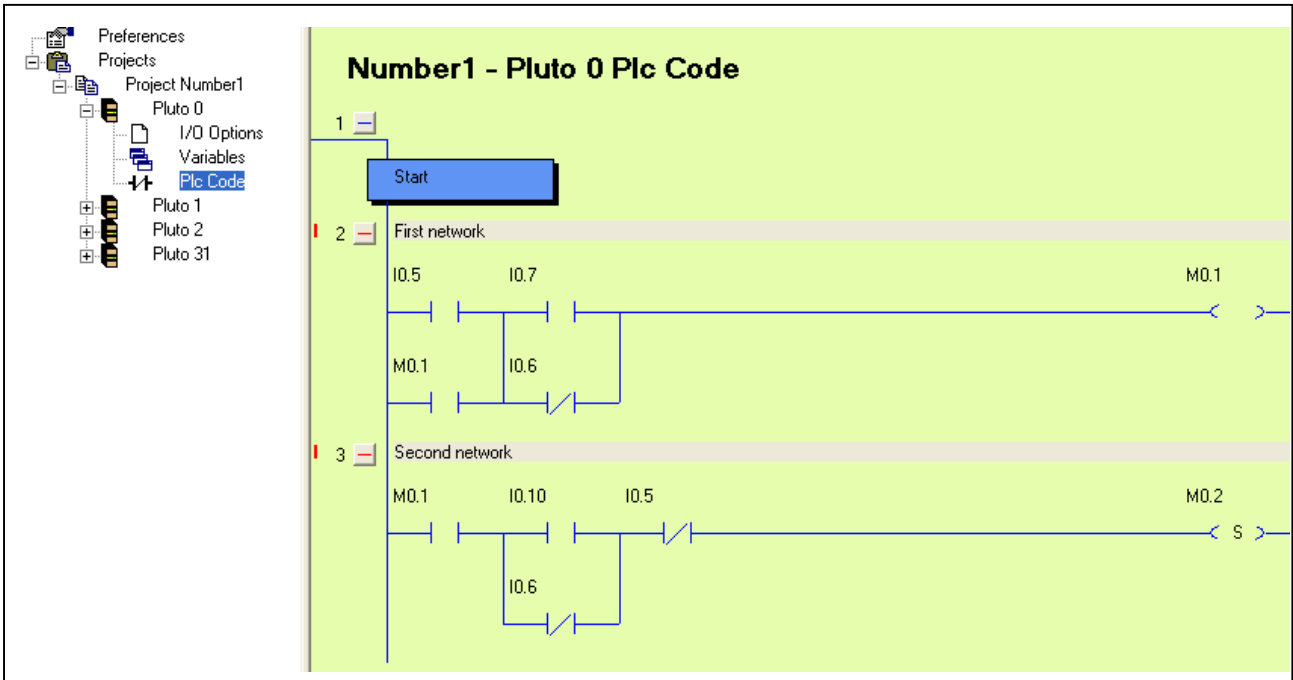

The ladder logic program is built up with networks, also called rungs. These are numbered on the left side.

By a right mouse click in a network the following dialog box appears. The options Cut, Copy, Paste and Delete Networks operate as most other windows programs and lead to new dialog boxes.

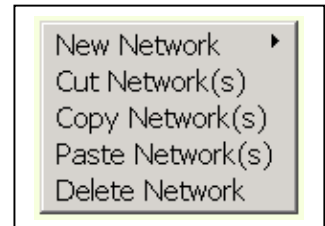

By selecting "New Network" a new network is opened and inserted below the network where the mouse click is carried out.

## 12.1 Edit mode

Edit mode can be entered in two ways, either by selecting “New Network” as described above or by a left mouse click on an existing network. Only one network can be edited at a time.

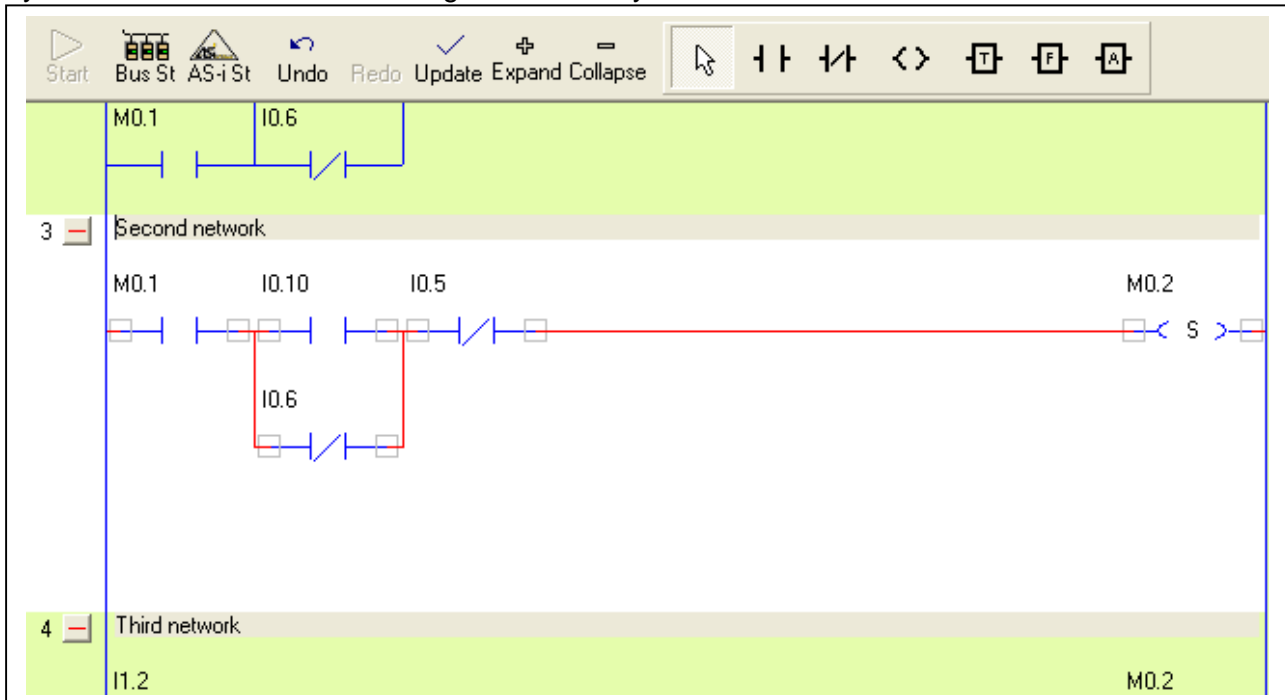

A network in Edit mode is high-lighted, the lines between the components are red and hit boxes are shown. The hit boxes show where it is possible to connect a line. In edit mode it is possible to drag around, insert, disconnect, delete, etc. lines and ladder components.

### Operations in edit mode:

**Draw a line:** Do a left mouse click (and release the button) in a “hit box” for a component. The “hit boxes” show the connection points. Move the cursor to the component where the end of the line is to be connected and fix it with a left click.

**Change a line:** By clicking the mouse on a line outside the “hit boxes”, the line is grabbed. It is now possible to:

- Stretch it to a third point and fix it with a left mouse click.
- Go to one of the “hit boxes” and disconnect it with a left mouse click. When the line is detached it can be fixed to another component or deleted with a mouse click outside a “hit box”.
- Make a right mouse click and a dialog box “Delete line” is shown.
- Un-grab it with a new left mouse click.

**Change components properties:** A double left mouse click on a component leads to a dialog box for changing Variable name, NO, NC, Pulse function etc.

**Change components:** By a right mouse click on a component a dialog box with three options is shown.

- “Components properties.” for giving or changing the name or function.
- “Disconnect component” for deleting all connections to the component.
- “Delete component” for deletion of the component.

**Moving components:** Press and keep left mouse button down on a component and drag it. Release the mouse button at the new place required.



## 12.2 Tool bar

The tool bar is shown in edit mode and is used for the insertion of ladder components.



To insert a component, click on the corresponding symbol. The cursor then takes the form of the symbol. Place it where you want to have it in the network, fix with a left mouse click and fill in the properties.

Tool bar components:

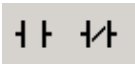

Standard ladder contact components. (Leads to the dialog box below.)

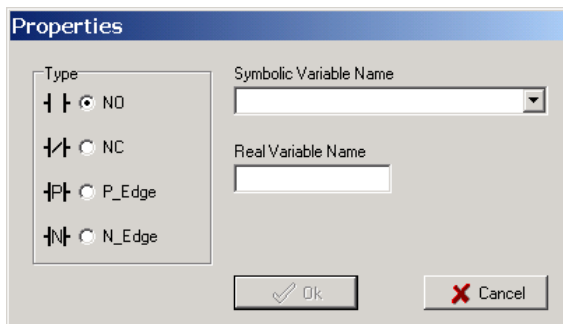

The dialog box is titled "Properties". It has a "Type" section on the left with four radio button options:  NO,  NC,  P\_Edge, and  N\_Edge. To the right, there is a "Symbolic Variable Name" dropdown menu and a "Real Variable Name" text input field. At the bottom, there are "Ok" and "Cancel" buttons.



Standard ladder output components.  
Leads to the dialog box below.

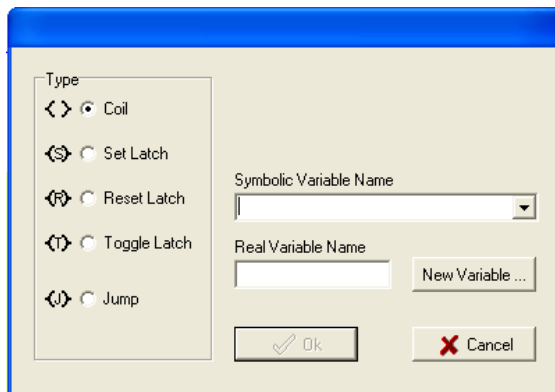

The dialog box is titled "Properties". It has a "Type" section on the left with five radio button options:  Coil,  Set Latch,  Reset Latch,  Toggle Latch, and  Jump. To the right, there is a "Symbolic Variable Name" dropdown menu, a "Real Variable Name" text input field, and a "New Variable ..." button. At the bottom, there are "Ok" and "Cancel" buttons.



Timers  
Leads to a dialog box for selection of different types of timers.



## Function blocks

By clicking on “F” a list with available function blocks appears. This list is however dependant on if a function block library is selected. See “Selection of function block library”.

The function blocks are described in separate documentation.

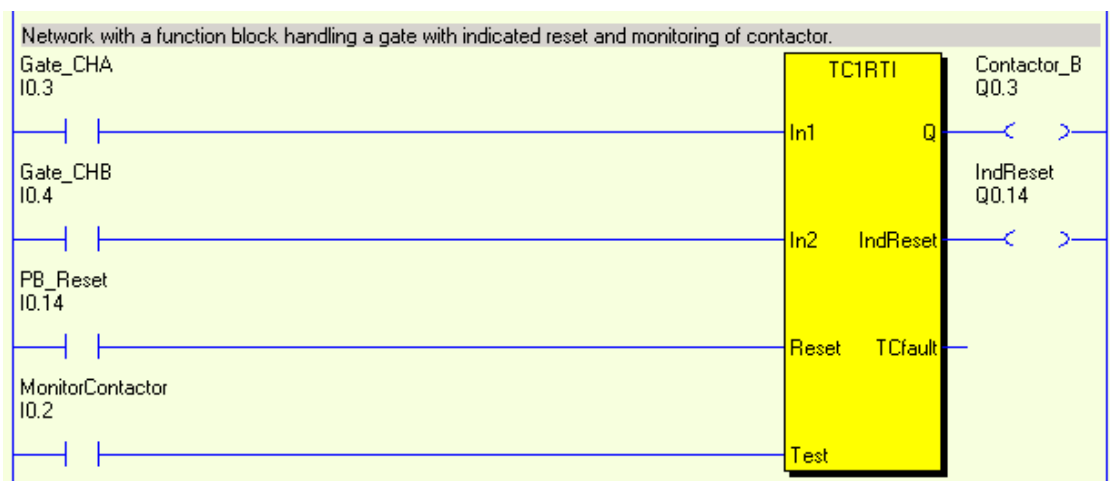

Example of network with function block



## Arithmetic functions and constants.

A click on the symbol leads to the following drop down list.

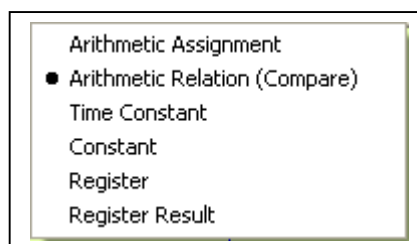

- “Arithmetic Assignment” assigns a value to a register. This assignment can contain a mathematic operation (+, -) as well as a direct assignment of a value.
- “Arithmetic Relation” makes a comparison of a register.
- “Time constant” is used for function blocks requiring a timer value as input.
- “Constant” is used for function blocks requiring a constant value as input.

By selection of one of these options a new dialog box is shown where the value, comparison etc. is written in text form. (See also Part2 Programming manual)

**Arithmetic Relation - Properties**

Operand 1

Register

Symbolic Register Name

Real Register Name

Operand 2

Register

Symbolic Register Name

Real Register Name

Relation

=

<

>

<>

<=

>=

(=)

In the ladder diagram the arithmetic function looks as follows.

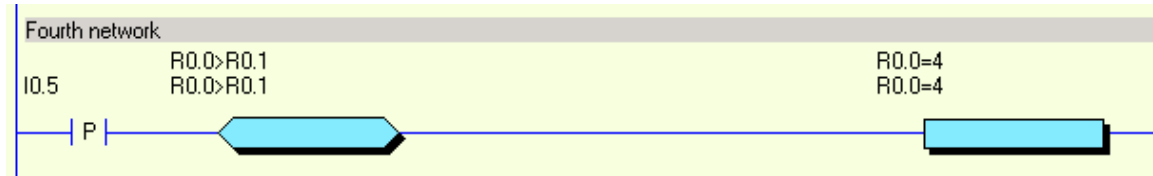

By positive edge on input I0.5 and register R0.0 is greater than R0.1, R0.0 is set to 4.

### 12.3 Update / Undo



To exit edit mode either the “Update” or “Undo” buttons can be used. Update confirms the changes and Undo restores everything in the edited network as it was before entering it.

Instead of “Update” button:

- “F3” key or
- “Esc” followed by answering Yes in a dialog box, can be used.

Instead of “Undo” button:

- “F2” key or
- “Esc” followed by answering No in a dialog box, can be used.

### 12.4 Expand / Collapse networks



The ladder diagram can be controlled to be in either expanded or collapsed form. In collapsed form only the comment for a network is shown and the ladder logic is not visible. The buttons in the tool bar controls all networks in the whole ladder diagram.

To control each network separately there are “+” and “-“ buttons on the left side of each network which can be used.

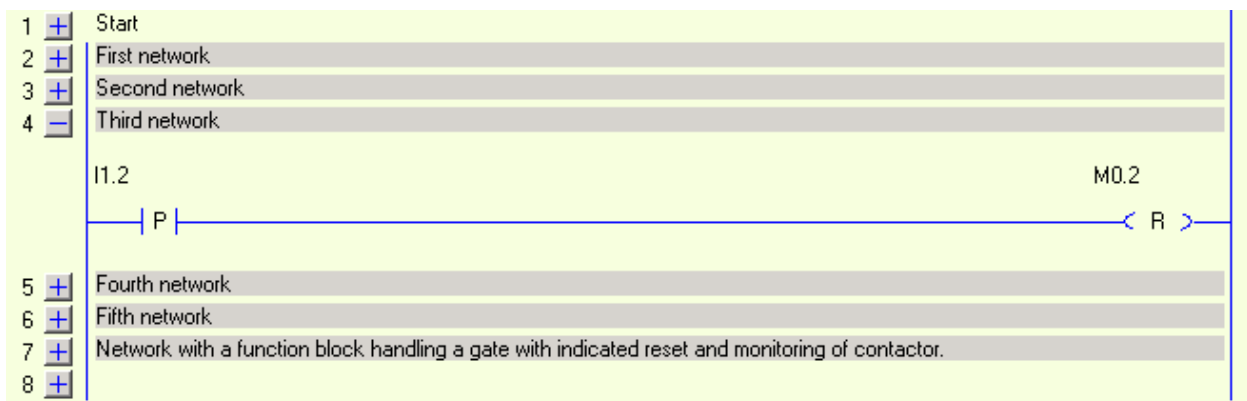

Ladder diagram with collapsed and expanded networks

## 12.5 Drag-and-drop

Components and function blocks can be copied from one network to another with “drag-and-drop” technique. The network where the components are to be placed shall be in edit mode. Put the cursor on the component which shall be copied, and left click. A component symbol will be shown. Just drag this symbol in place and release.

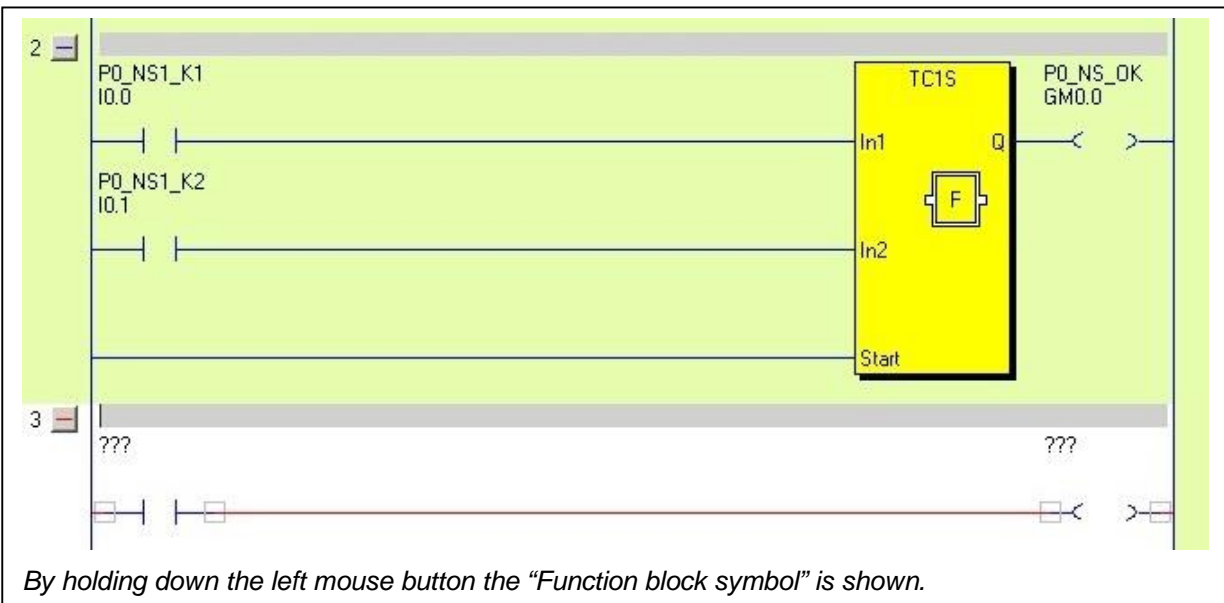
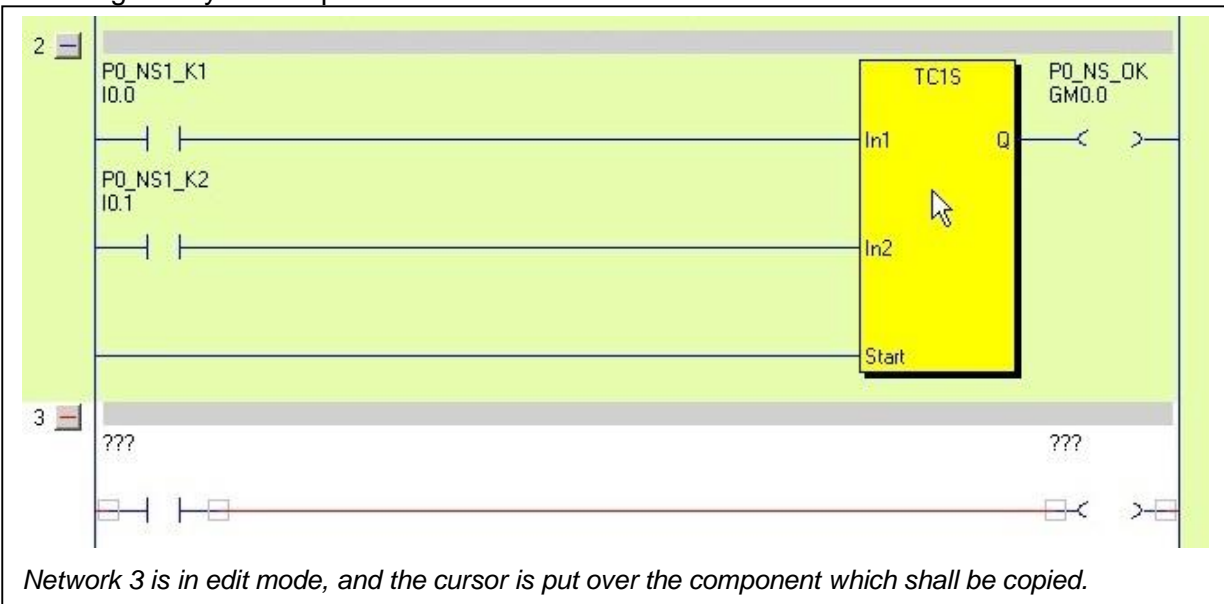

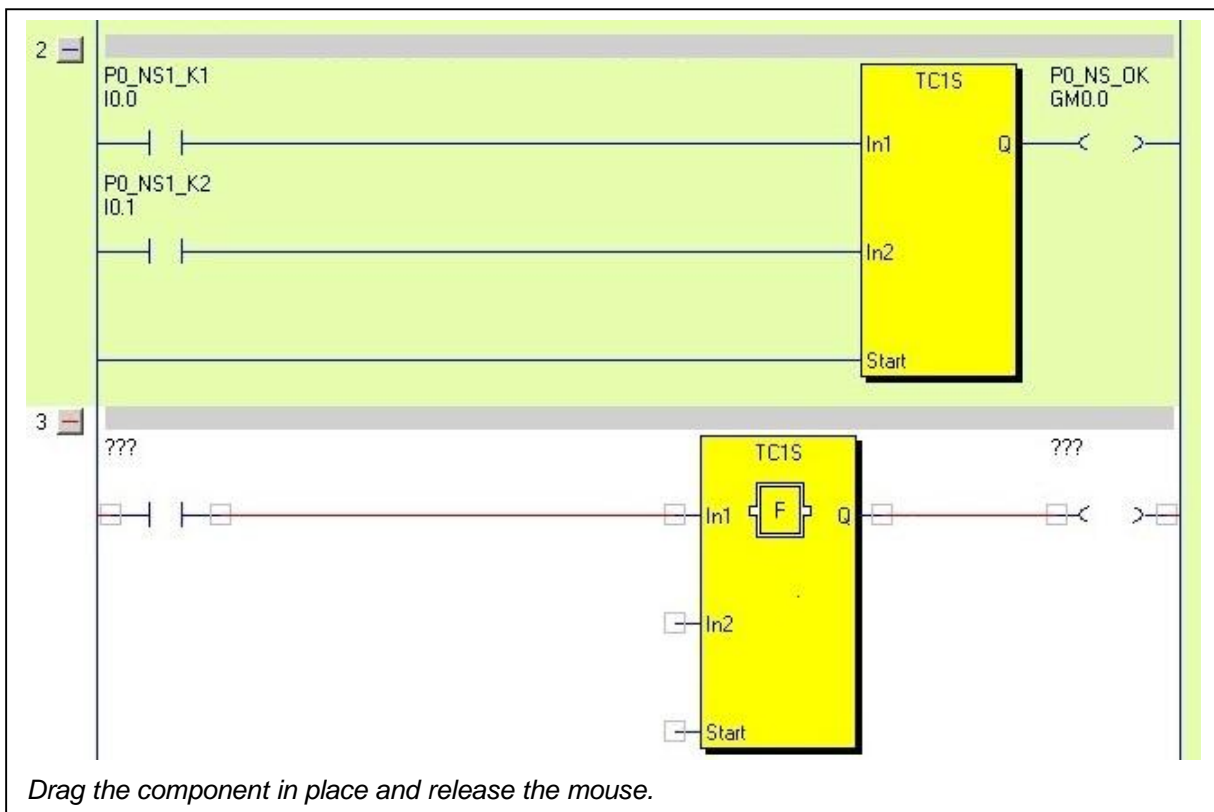

## 12.6 Options

The intention with options is to make it possible for someone without detailed knowledge of the whole program to make some changes in the code. The same PLC program can be used for different variants of a machine. By “checking” or “un-checking” a checkbox in the PLC code a memory is set or reset. This memory is then used later in the code to bypass a function, for instance a switch, for variants of the machine which are not equipped with this switch. This makes it easy to adapt the program for the specific application. Options work very well together with password protection (see 4.1 Password protect), where options can be configured to have a different degree of protection than the rest of the code. Note that options must be in the beginning of the “PLC” code.

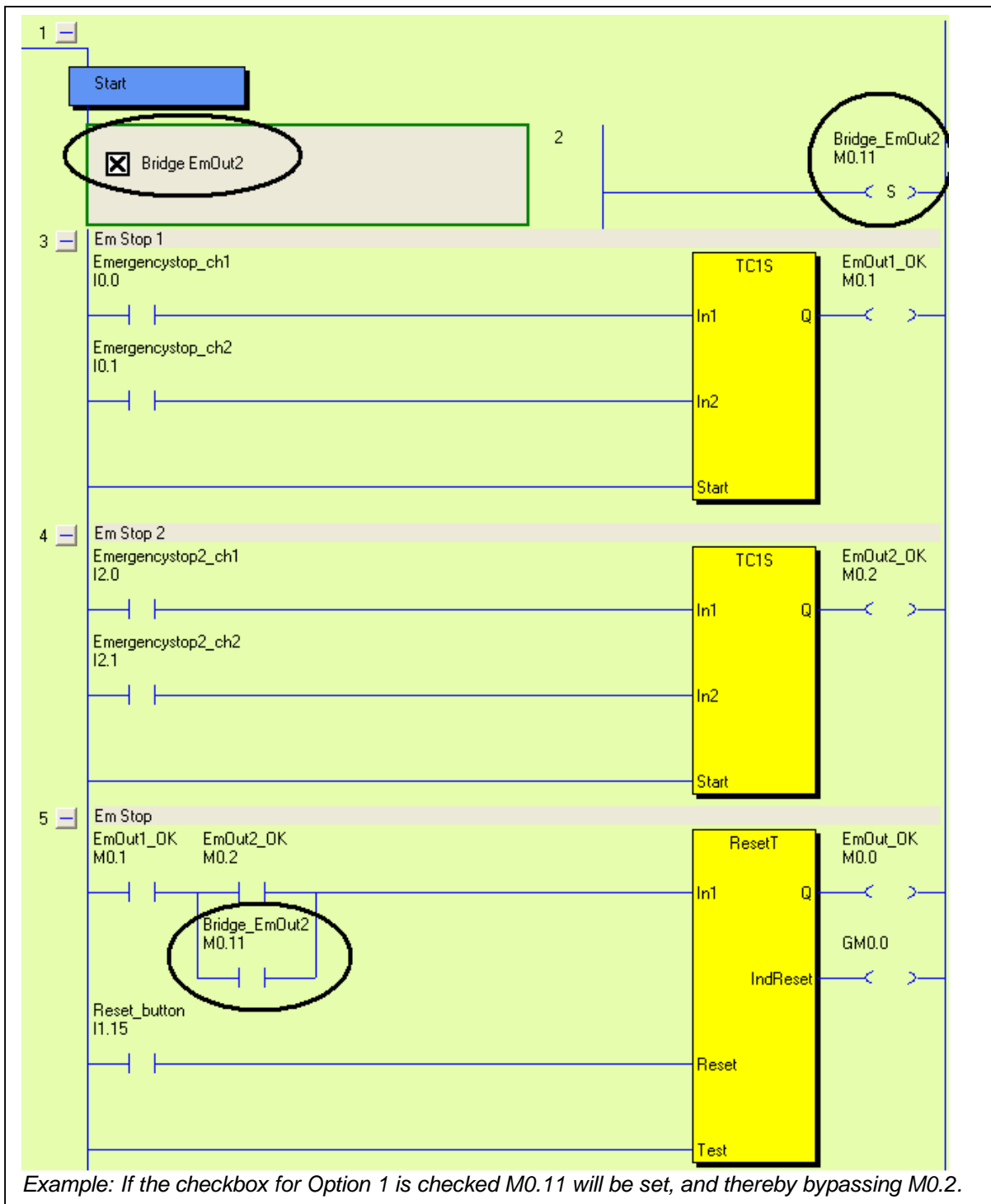

To program an option, right click in the network area:

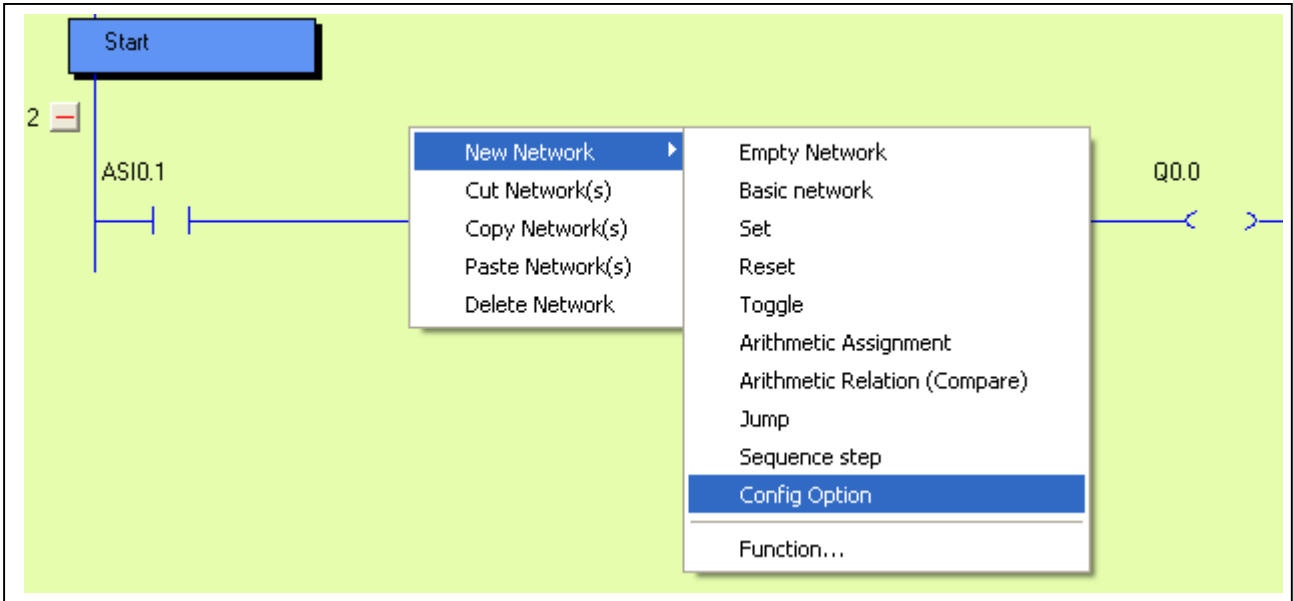

Choose "New Network" and "Config Option":

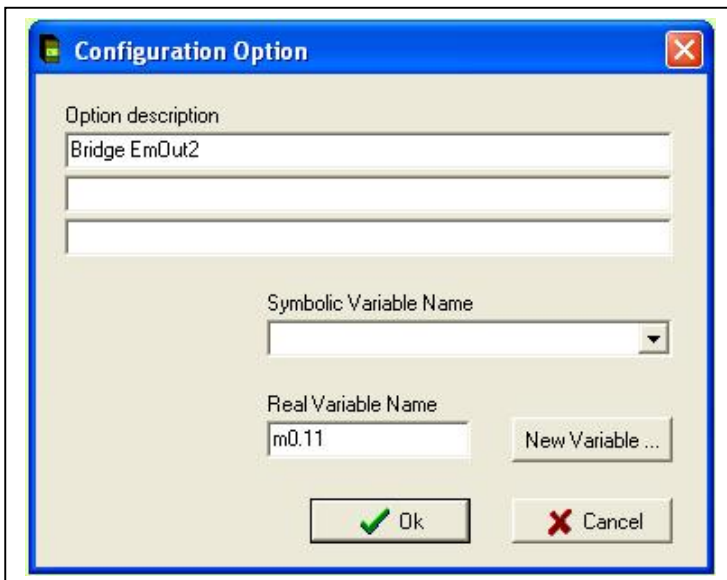

Type in Option description and variable name (only Memories can be used for options), and click ok:

To enable the option, mark the checkbox and confirm by clicking "OK".

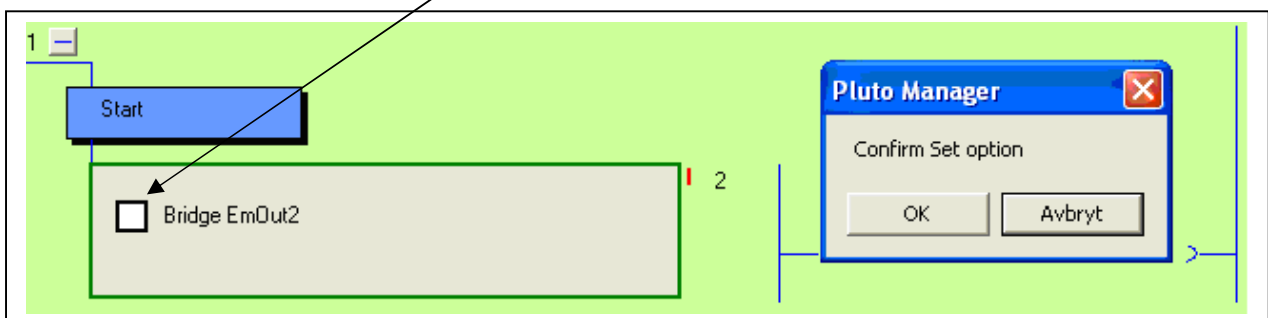



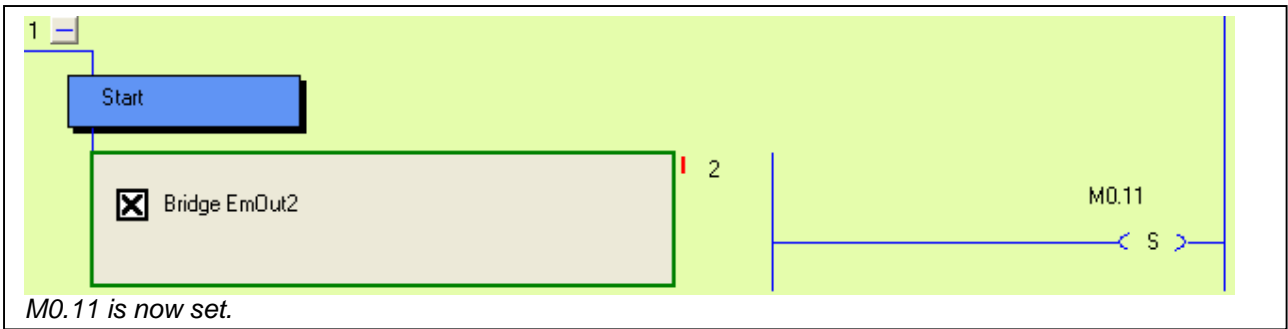

## 12.7 Sequences

In addition to the ordinary PLC code it is possible to have 9 Sequences with a maximum of 254 steps in each sequence.

To open a new sequence:

Right click on the Pluto symbol in the tree menu à Select "New Sequence" à Enter a sequence number 1-9 in the next dialog box.

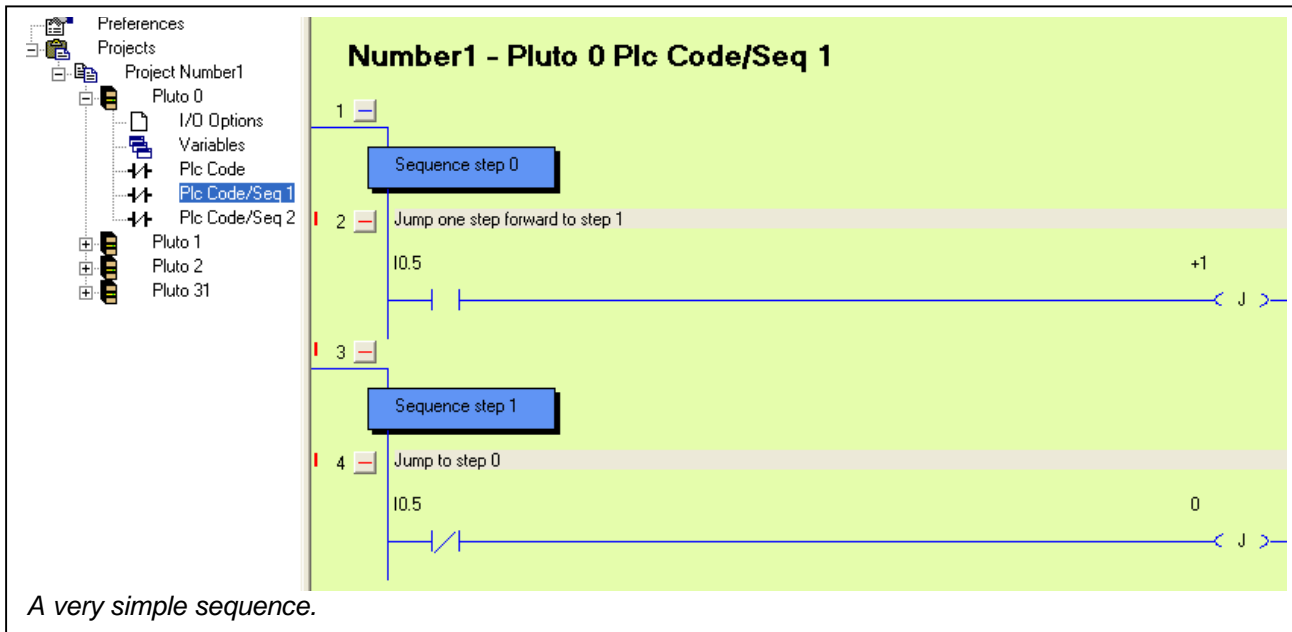

## 13 Project setup

### 13.1 Function libraries

The Pluto system offers the possibility to use pre-programmed function blocks / macros for different safety functions and safety devices. These function blocks are stored in separate library files with file extension .fps. Standard libraries are included in Pluto Manager but it is also possible to make user specific libraries. Several library files can be loaded in one project.

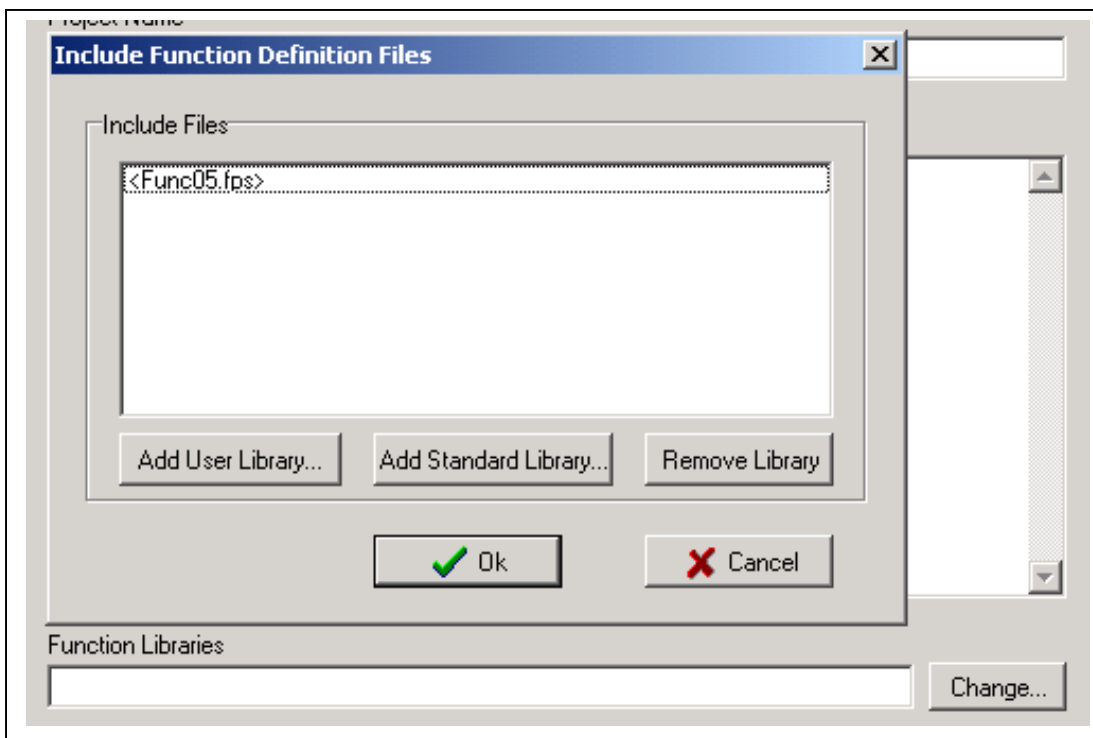
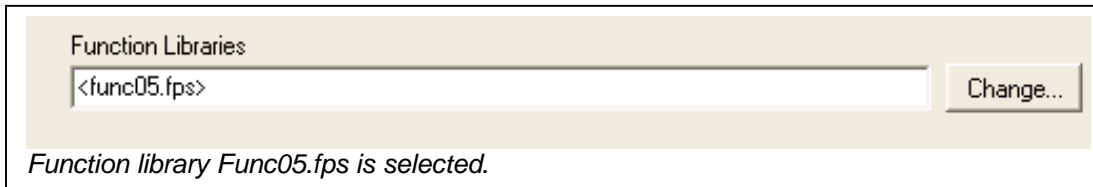

By a mouse click on "Function libraries"/ "Change" on the Project [Name] page a dialog box with three options appears.

- "Add standard Library": Pluto Manager looks for files at "..\PlutoManager\Library" where they are normally stored by the installation program.
- "Add User Library": Pluto Manager looks for the files in the directory where the project files are stored. User libraries are files with user specific function blocks.  
For making a function block see special manual.
- "Remove Library" is used for deleting a file in the list.

## 13.2 Merge projects

It is possible to merge two different projects into one. Open the two projects which shall be merged together in Pluto Manager. Right click on one of the project names and select “Merge Project”.

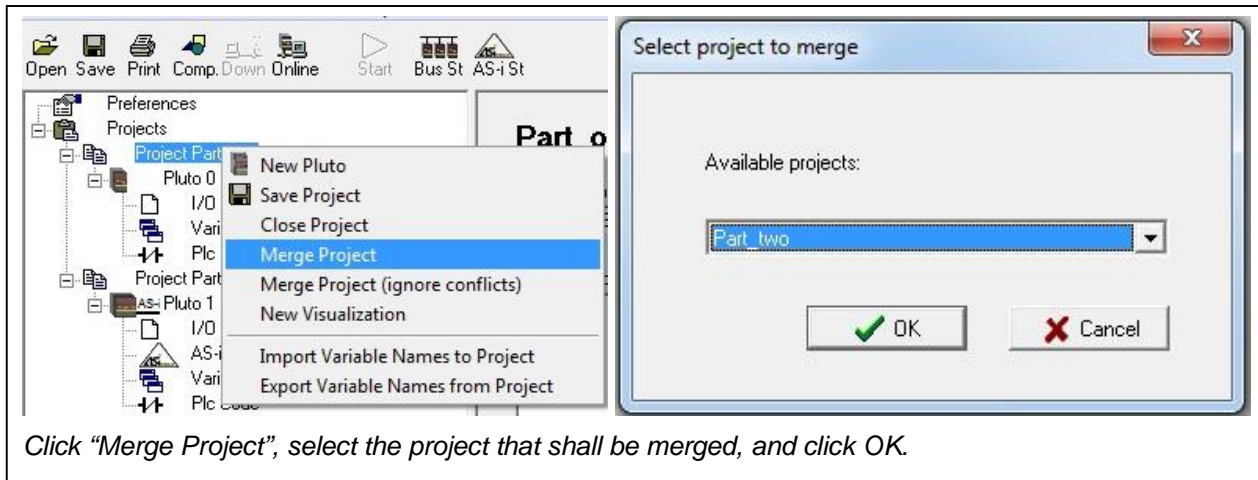

Click “Merge Project”, select the project that shall be merged, and click OK.

It is a requirement that all Pluto units are uniquely numbered and that all variable names are unique, i.e. that no variable name is used in both projects.

If “Merge Project (ignore conflicts)” is selected the same variable name in both projects will be allowed, but the variable name will only be shown in the PLC code for the Pluto where it was defined. In the example below both I0.0 and I1.0 are named “Input\_zero”.

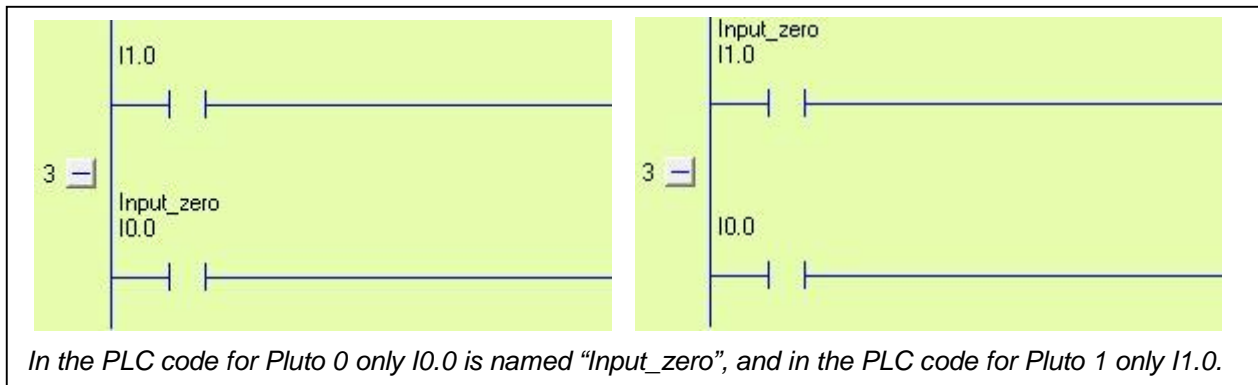

In the PLC code for Pluto 0 only I0.0 is named “Input\_zero”, and in the PLC code for Pluto 1 only I1.0.

## 14 Compilation



Pluto Manager saves the program in a file with extension “.sps”, but this cannot be downloaded to a Pluto unit before being compiled. The compiler checks the program code in the sps-file against syntax faults and produces a file in hex format (.hps), which can be downloaded.

By clicking on the “Comp” button the compilation is started and a text window appears on the screen. At the end of the compilation the message “0 Error (s) detected ..... Result=OK” appears, if everything is passed. Pluto Manager prevents most syntax faults but not 100% and it can therefore happen that the compiler gives fault messages.

**Note.** Pluto Manager and the compiler just checks for syntax faults, when the code is not corresponding with rules of the language. Logic faults, like an emergency stop that controls an incorrect output cannot be detected by the software tools. Programs must therefore be reviewed and safety applications carefully tested before the use.

# 15 General Preferences



This page contains preferences related to the PC-computer.

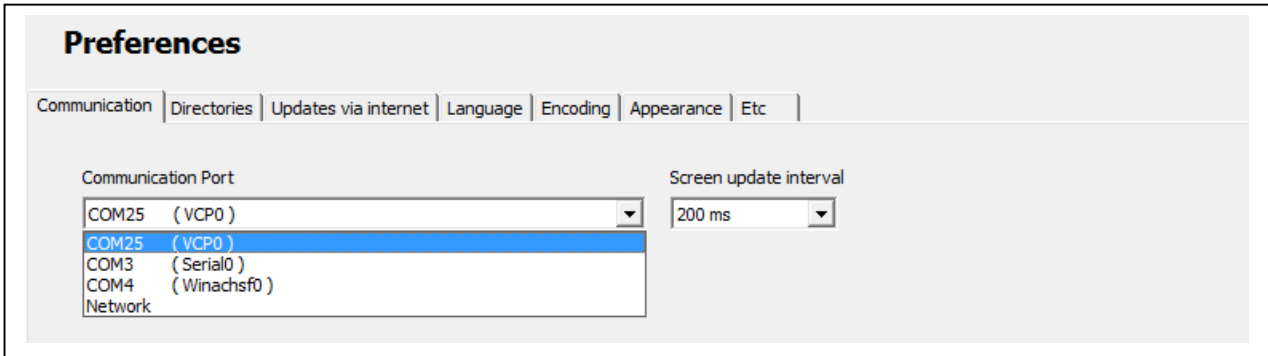

For communication via Pluto USB cable, select the first “VCP” COM port from the list. For communication via the serial port, select the “Serial” COM port from the list. Network is used for remote monitoring/control, see chapter 17.2.

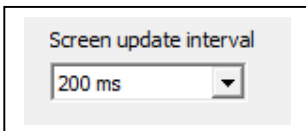

Update interval in online mode. Lower update interval makes the computer slower.

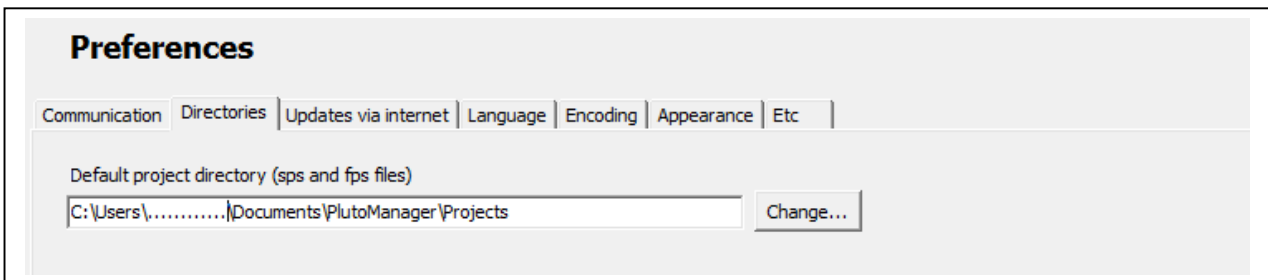

The Pluto Manager installation creates a “Projects” folder. The default location for this will be C:\Users\.....\Documents\PlutoManager\Projects if no other location is specified.

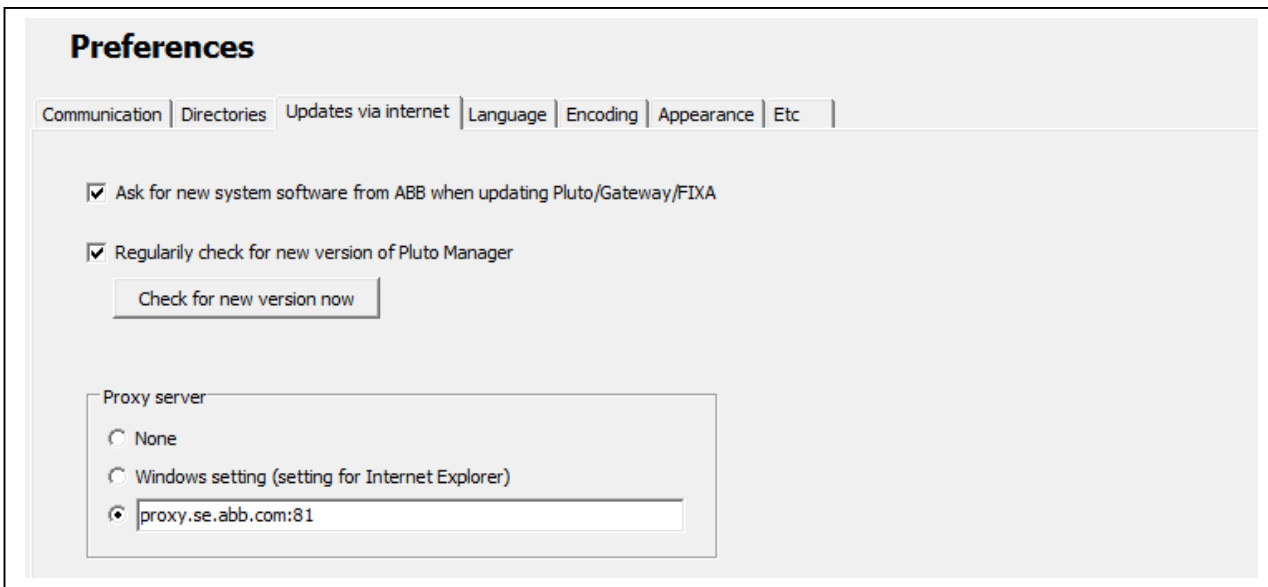

In order for Pluto Manager to have internet access it can be necessary to change the proxy server setting.

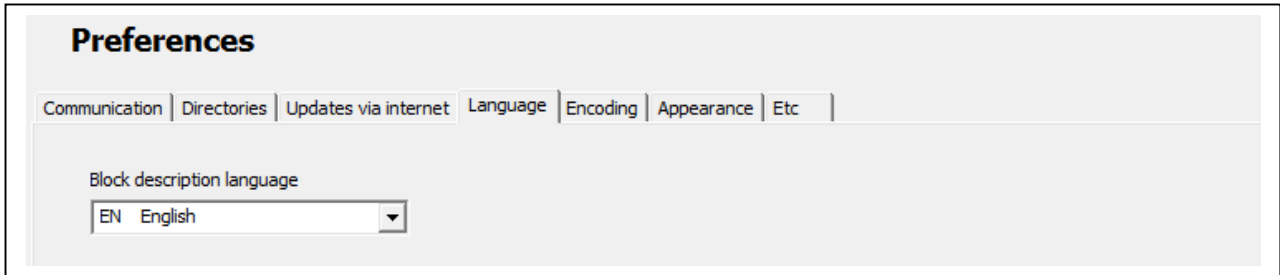

The function blocks have a description, visible by a right click/Function description on them. The language of this description can be selected here.

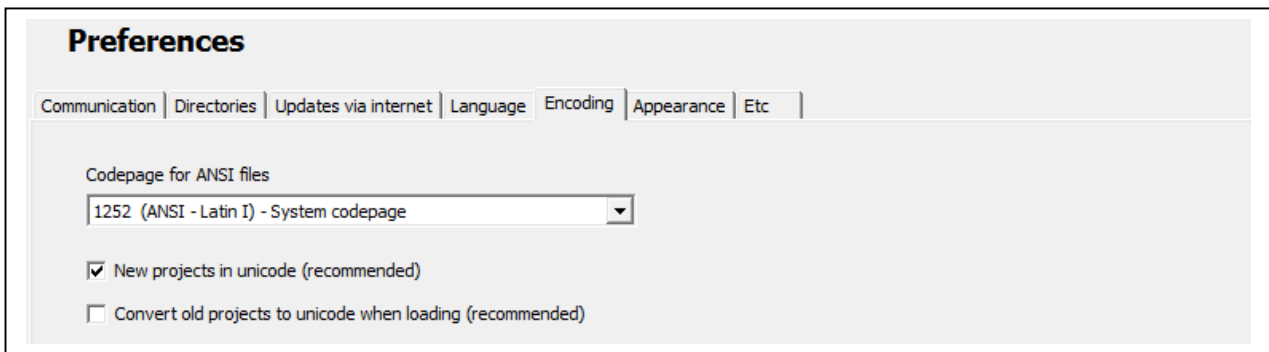

For older project which are not in Unicode the codepage can be specified. It is also possible to convert old projects to Unicode.

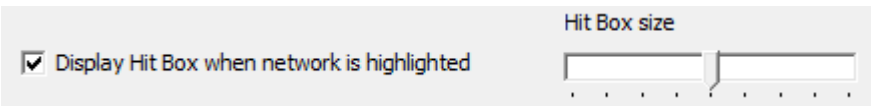
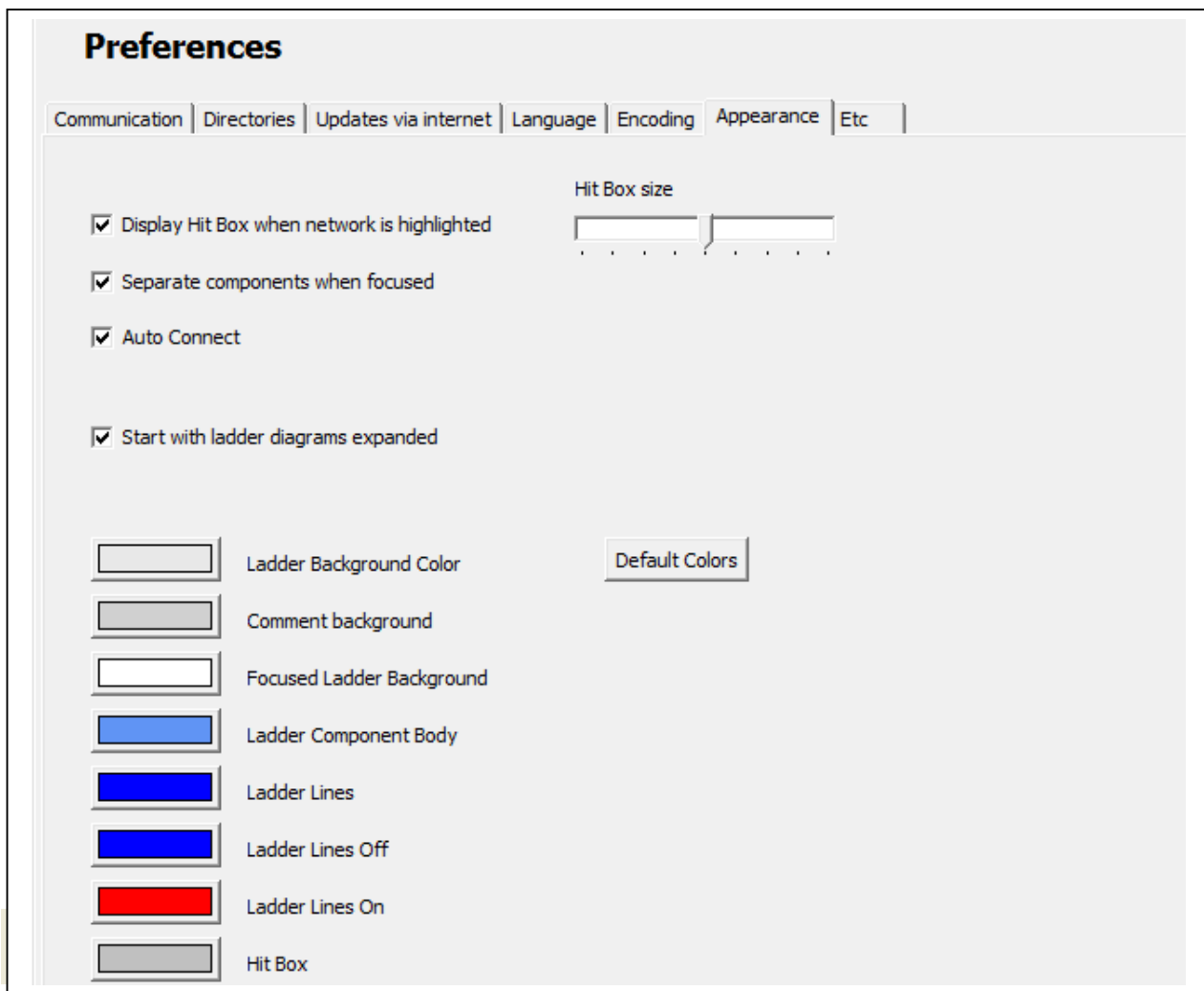

The size of Hit Boxes and if they shall be shown in the ladder diagram can be set.

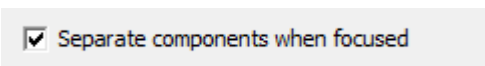

In Edit mode the ladder components are separated from each other.

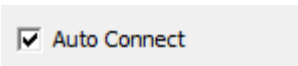

When Auto Connect is ticked, ladder components are automatically connected when they are inserted on a line.

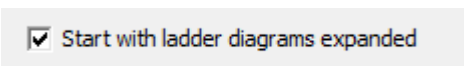

As default the ladder diagrams are opened in expanded from.

### Colours

The colours in Pluto Manager can be changed by the user.



# 16 Online operations

## 16.1 Communication

The system communicates with an ordinary PC through a special cable with a 4-pin connector connected to one of the COM ports on the PC, or via a special Pluto USB cable connected to a USB port. Go to the page “Preferences” and select COM port.

## 16.2 Tools menu

Most of the online functions can be found under “Tools” menu

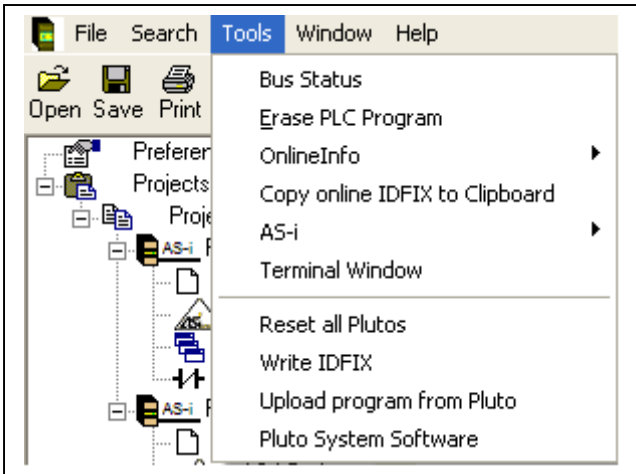

### 16.2.1 Erase PLC Program / Change of password

Under “Tools” à “Erase PLC program” it is possible to erase the PLC program. (Password is required.)

This function can also be used in order to change pass word. When down loading a PLC program into an erased Pluto the user can select a new password.

### 16.2.2 Online info

Under “Tools” à “Online Info” it is possible to read data in “real time” from a Pluto unit.

For the normal user, Project Name and Compile time is the most important data.

To go online, the Project name must match with the Project name of the opened project in Pluto Manager.

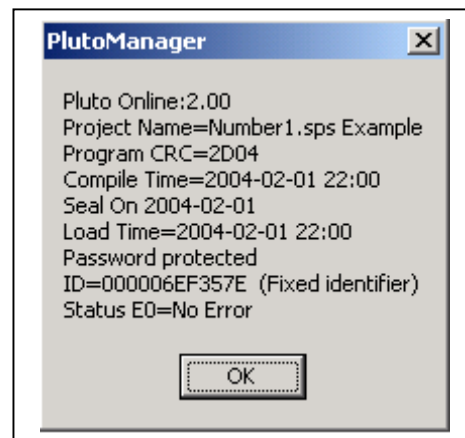

### 16.2.3 Copy online IDFIX to Clipboard

The identifier circuit “IDFIX” is read and automatically copied to the clipboard. By a Ctrl+V it can then be pasted into the field “Identifier Number”.

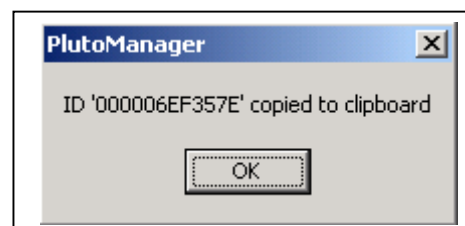

## 16.2.4 Terminal window

Another way to communicate with a Pluto unit, is to open a terminal window. In this mode the PC is just a terminal. Everything typed on the keyboard is sent to the Pluto unit and everything written in the terminal window is written by the Pluto unit.

A lot of things can be monitored via the terminal like I/O:s, compile date, program name etc.. It is also possible to load new programs by typing "pl" followed by a click on the "Send File"-button. By typing "h" (help) available commands are listed.

Instead of this terminal a standard terminal program can be used such as HyperTerm in Windows.

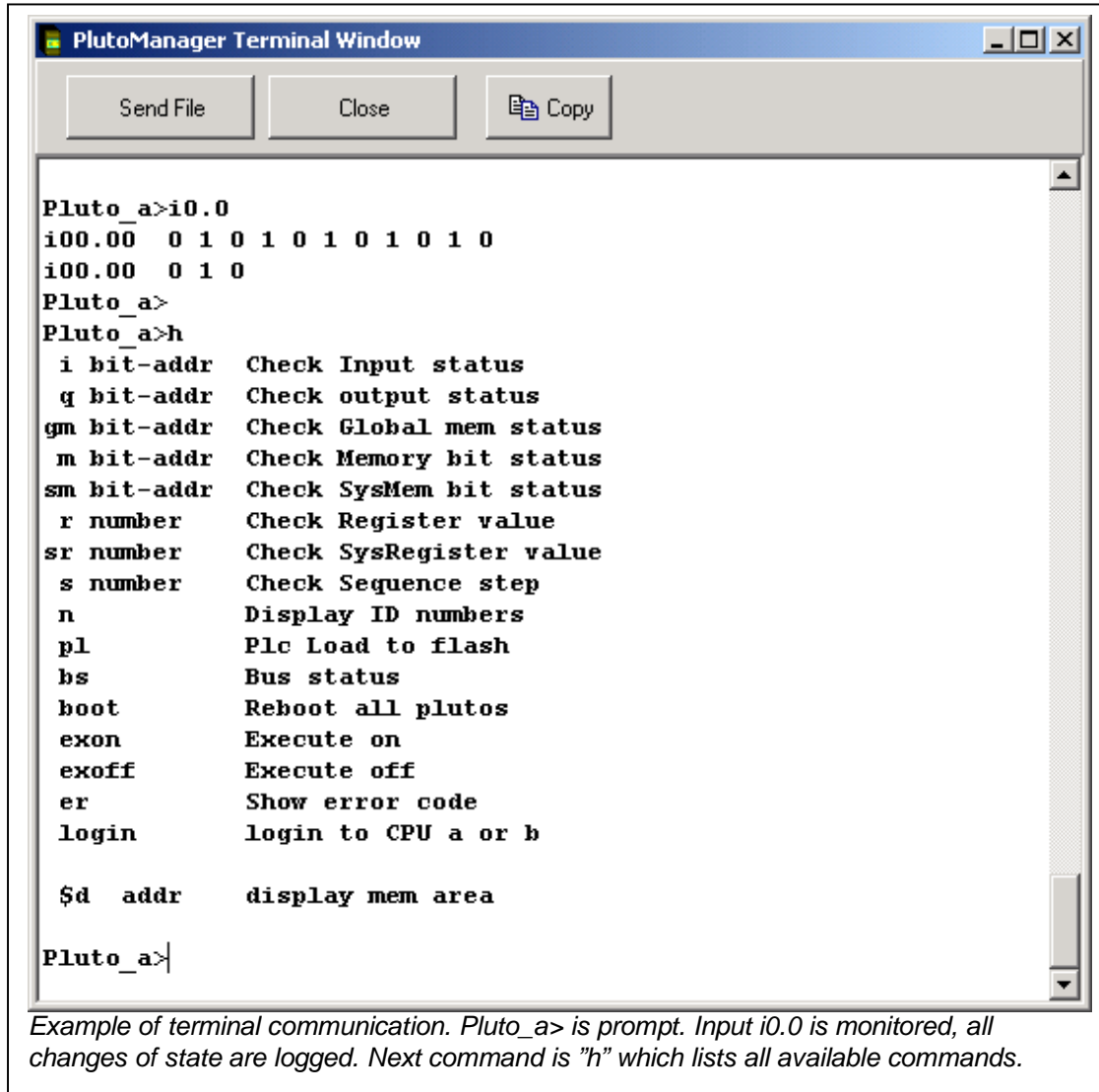

## 16.2.5 Reset all Plutos

The command will Reset / (reboot) all units connected to the bus. The Reset has the same function as power off/on and can be necessary in situations as after change of baudrate or reset of some faults.

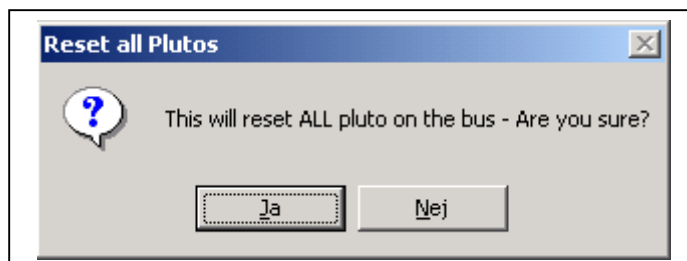

### 16.2.6 Write IDFIX

Function for programmable identifier circuits "IDFIX". It is possible to put in the number manually for example in order to make a copy of an existing, or let the system suggest a number. By selection of "Erase protected ID" the circuit can never be changed again.

Note that after writing ID the Pluto must be reset (power off/on) to enter normal operation again.

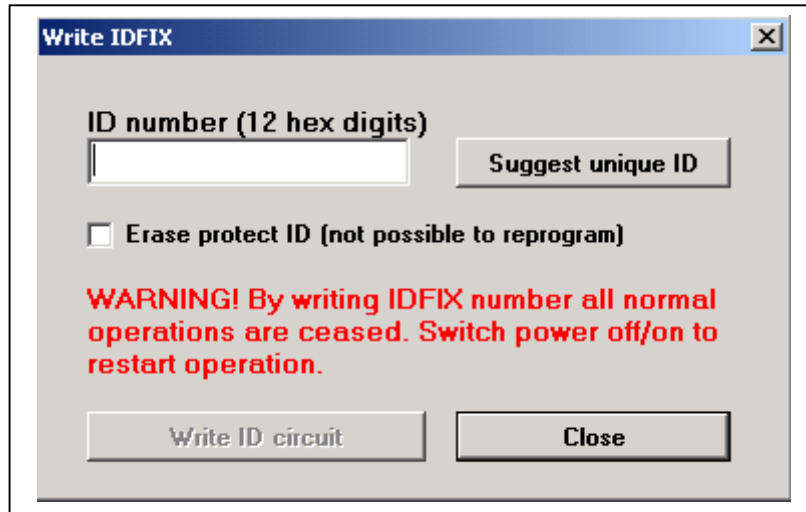

### 16.2.7 Upload Program from Pluto

The PLC program can be uploaded from Pluto and saved as a .uhx file on a PC. If "Include source code in compiled file" was selected when the program was loaded to Pluto (see 3.3 Include source file) the source file (.sps) can also be uploaded. Select "Upload program from Pluto" from the Tools menu.

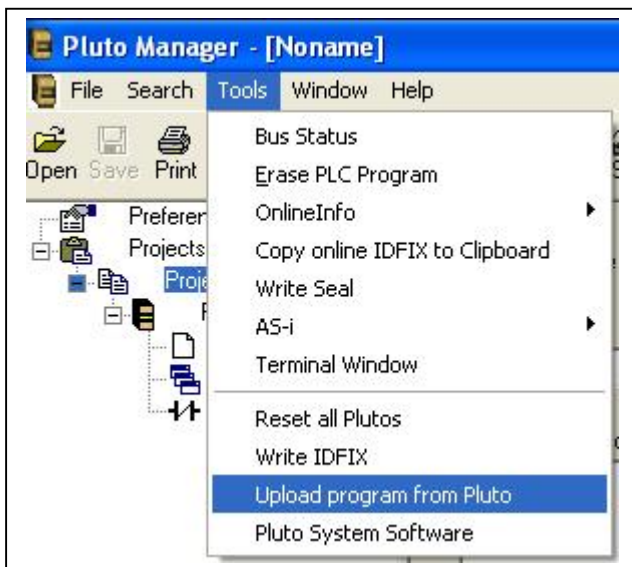

The requested password is the same as for program download.



If "Include source code in compiled file" was selected when the program was loaded to Pluto (see 3.3) both source file (.sps) and hexfile (.uhx) can be uploaded.

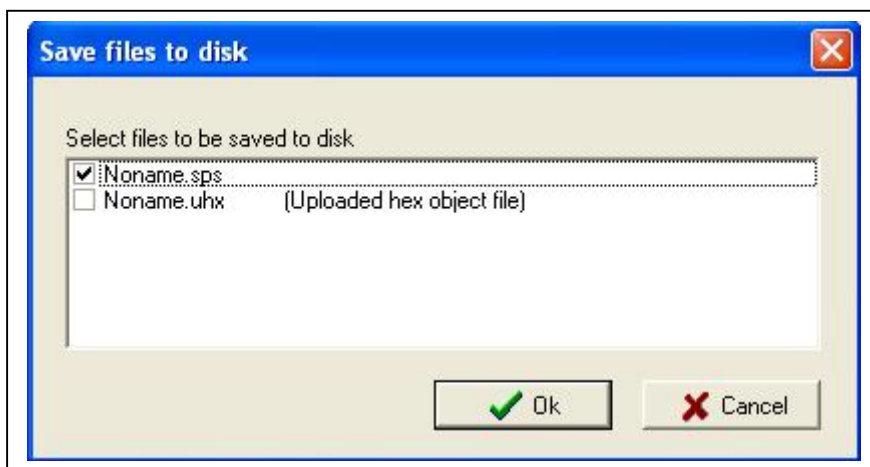

After the selection has been made the file(s) can be saved to an appropriate place on the PC.

A .uhx file can be downloaded again with the command "pl" in Terminal window. Type "pl" and password. When asked "erase flash mem PLC area?" type "y". When "Ready, please start loading..." is shown, click "Send File" and select the correct .uhx file.

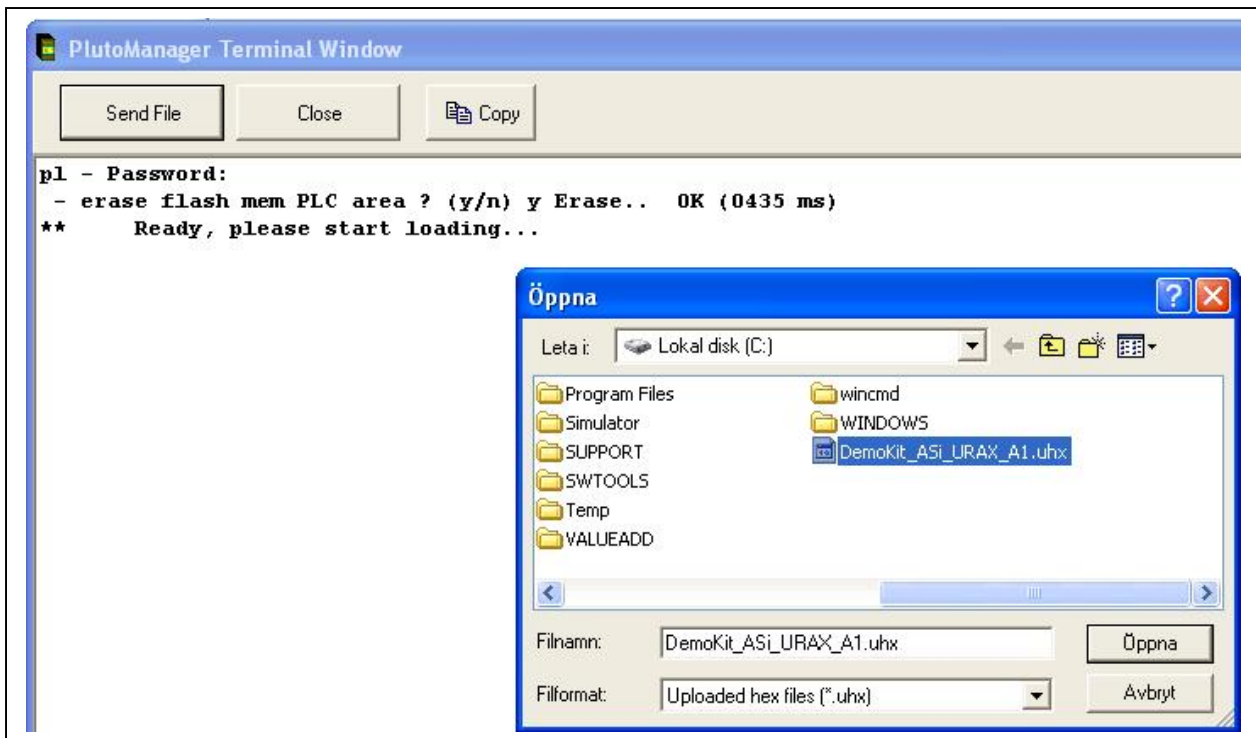

### 16.2.8 Pluto System Software (Updating the Operating System files in Pluto)

The Operating System can either be downloaded from [www.abb.com/jokabsafety](http://www.abb.com/jokabsafety) or automatically downloaded directly from ABB via Pluto Manager.

1. Connect Pluto to the PC with the Pluto programming cable.
2. Go to the "Tools" menu in Pluto Manager and select "Pluto System Software".

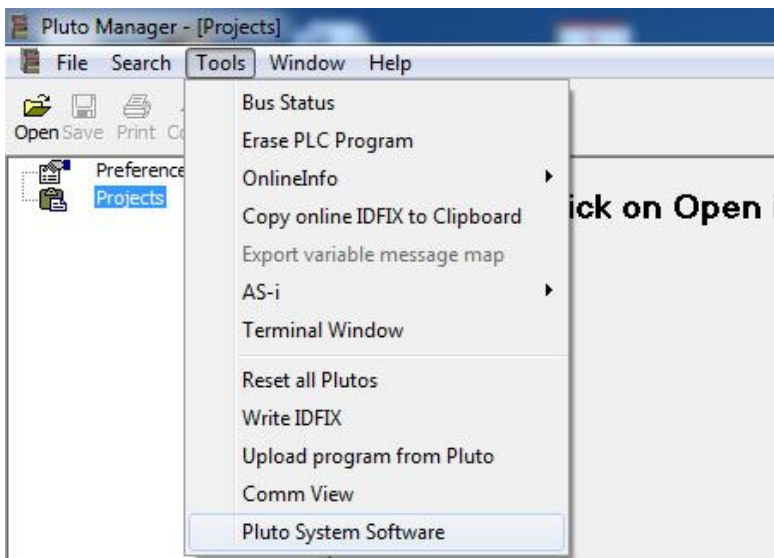

To automatically download the latest version directly from the ABB webpage, click "Yes".  
To load the OS from your local computer, select "No".

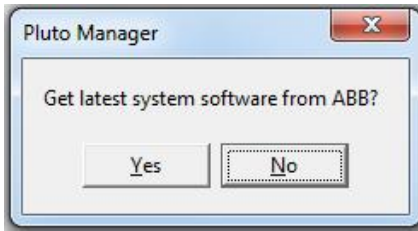

3. If "Yes" was selected: The latest version for the connected Pluto model is presented. (If "No" was selected, this box will not be presented.)



To download click "OK".

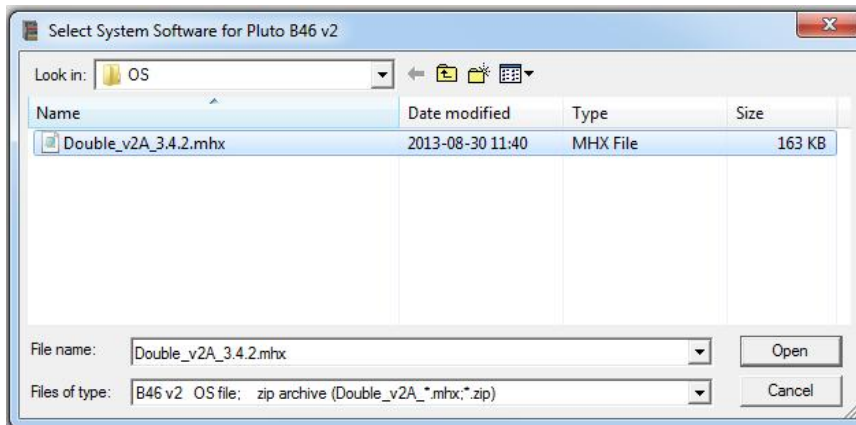

Select the OS and click "Open". The download will start.

If "No" was selected earlier (to not download directly from ABB), locate the OS file on the local computer and click "Open".



To confirm and restart Pluto, click "Yes".

### 16.3 Program download



To download a program from a PC to a Pluto unit press the “Down” button in the tool bar. Note that before a program can be downloaded it must be compiled. A fault message will tell if not. See Compilation.

After pressing the Down button, dialog boxes requiring passwords appear. The password must be 4-6 characters long.

If no fault messages appear:

“Couldn’t establish connection...” - No connection at all.

“Connection time out” - The communication is interrupted

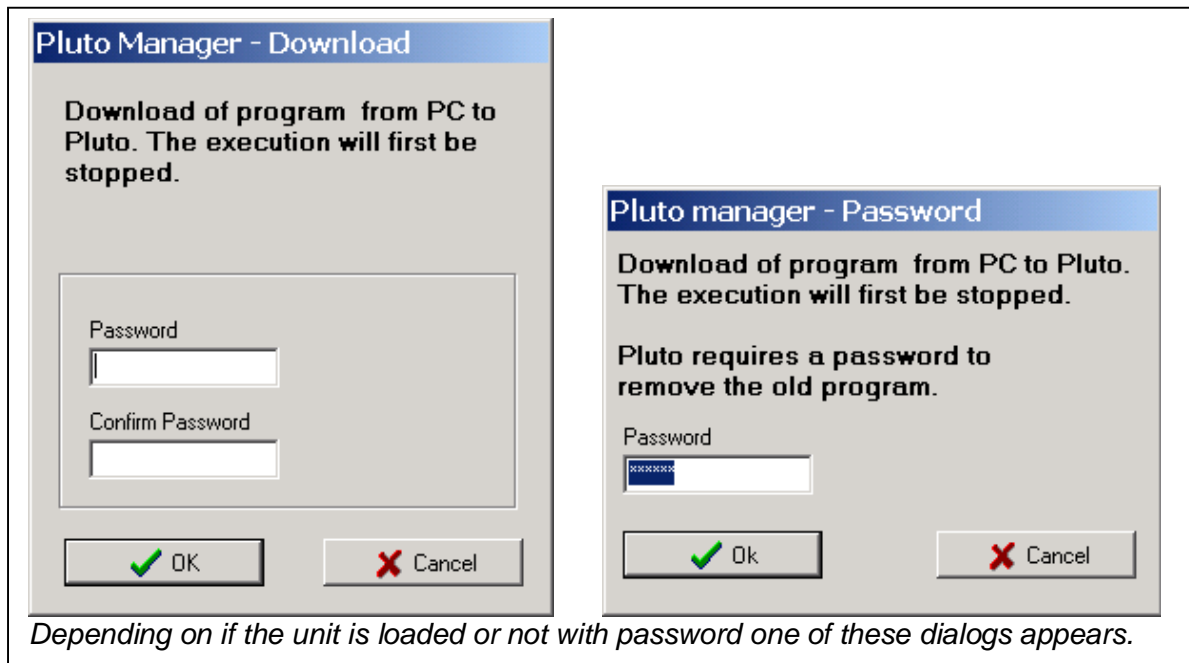

If everything works the message appears that the file is downloaded together with a selection if execution of program shall be started or not. If “No” is selected it is possible to start execution by pressing the Online button and then Start.

If the program project is for several Pluto stations and all are not connected to the bus a warning is given.

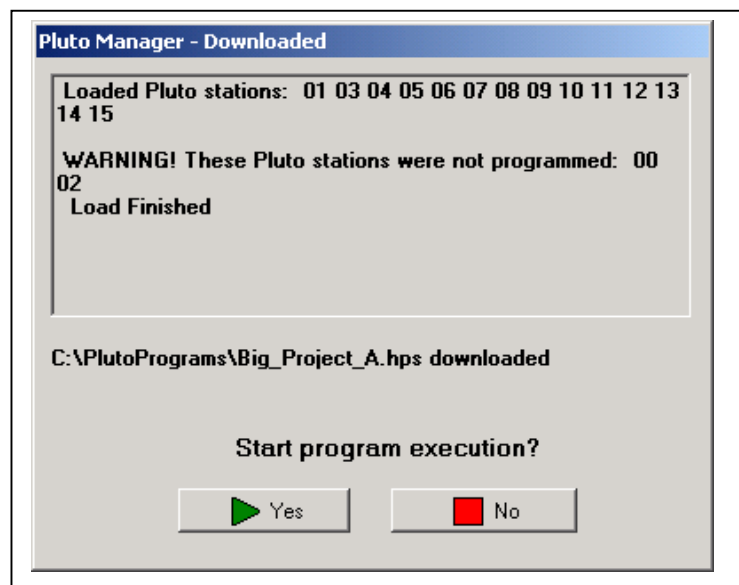



## 16.4 Insertion of Pluto unit in existing project afterwards

When Pluto units are loaded with program for several units they check each other so they have exactly the same version of the program code. By mismatch they do not accept each others I/Os.

If a unit belonging to a program project is connected to the bus afterwards the following situations can appear depending on what PLC program it is loaded with:

Alt. 1 - The new Pluto is empty of PLC program (message code Er20) and is fitted with correct IDFIX circuit.

The new Pluto can be loaded with program by a new download from the PC to any of the Pluto:s of the same program project.

It can also be programmed by using self programming without PC. By pressing the 'K' button in the Pluto front panel in 2 seconds the display flashes "L" which indicates that it is ready for self programming. By another activation of the "K" button the program load is started indicated by a steady "L" on the display.

Alt. 2 – The new Pluto is fitted with correct IDFIX circuit but loaded with wrong version of the program.

By connection all units of the project will give error code Er27 because they detect units belonging to their own program project but with mismatching program as the new unit has wrong version. The units will run the PLC program but will not accept I/Os in Pluto units with mismatching program. By a new download to any of the units in the project all of them will be updated with the same version.

## 16.5 Change of baud rate, error code Er26

A Pluto unit cannot change baud rate during operation. If a unit is loaded with a program with new baud rate it will continue with the old baud rate and indicate Er26. Er26 indicates that a unit runs with another baud rate than it is programmed for.

By reboot either by power off/on or via Pluto Manager "Tools" à "Reset all Plutos" the unit can change baud rate.

Also if an empty (Er20) standalone unit is loaded with program it will indicate Er26 and has to be rebooted in order to start with programmed baud rate.

## 16.6 Online



Using the button in the tool bar, the online mode can be switched on and off. In online mode the I/O status can be monitored either by opening a variable page or a ladder diagram.

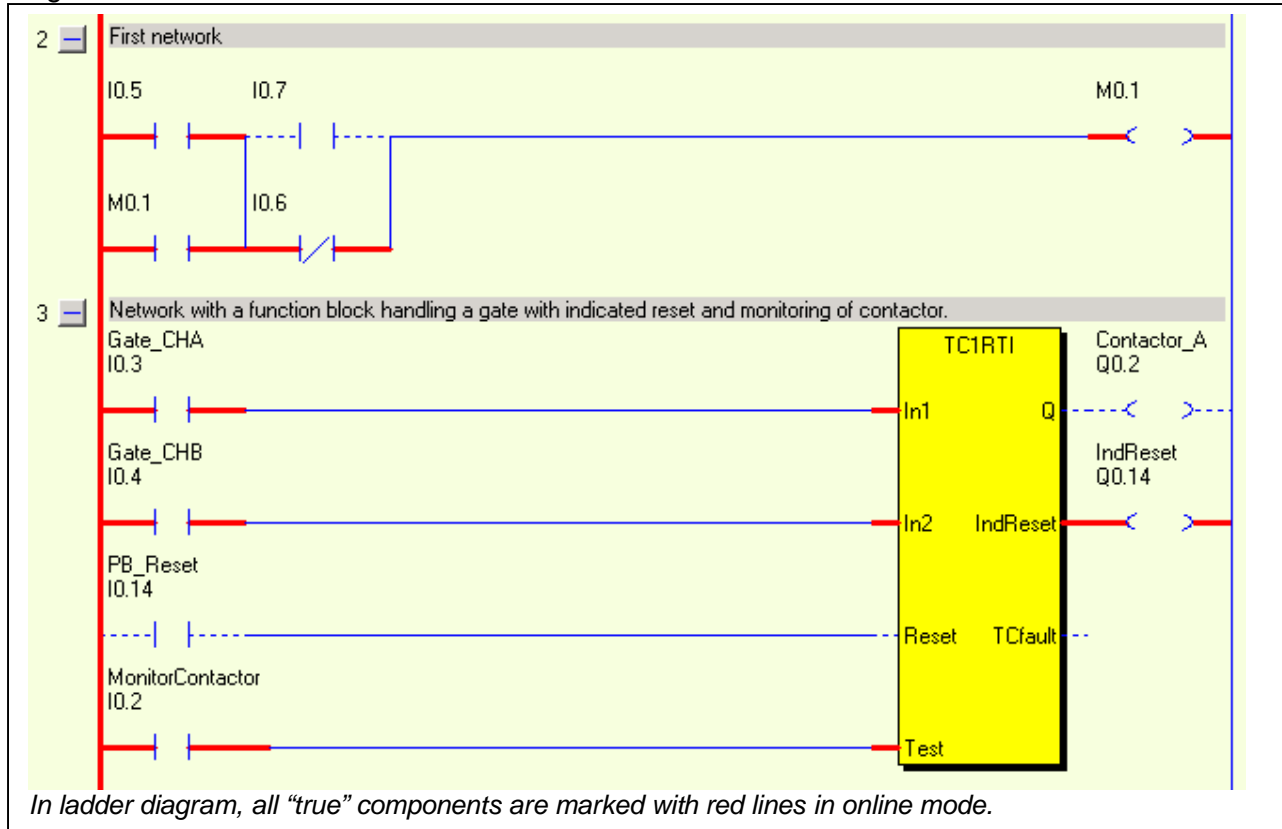

Pluto 0: E0=No Error

Status	Variable	Symbolic Name	De:
	I0.0		
	I0.1		
	I0.2	MonitorContactor	Mor
	I0.3	Gate_CHA	Inte
	I0.4	Gate_CHB	Inte
	I0.5		
	I0.6		
	I0.7		

In the windows for variables, a column with status indicators is viewed in online mode.  
In the tool bar, the error codes for the Pluto unit is showed with green text.



### Start and stop of program execution

In online mode the program execution can be controlled.

### Bus Status

In online mode it is possible to get an overview of the Pluto units connected to the bus via selection of "Tools" à "Bus Status"

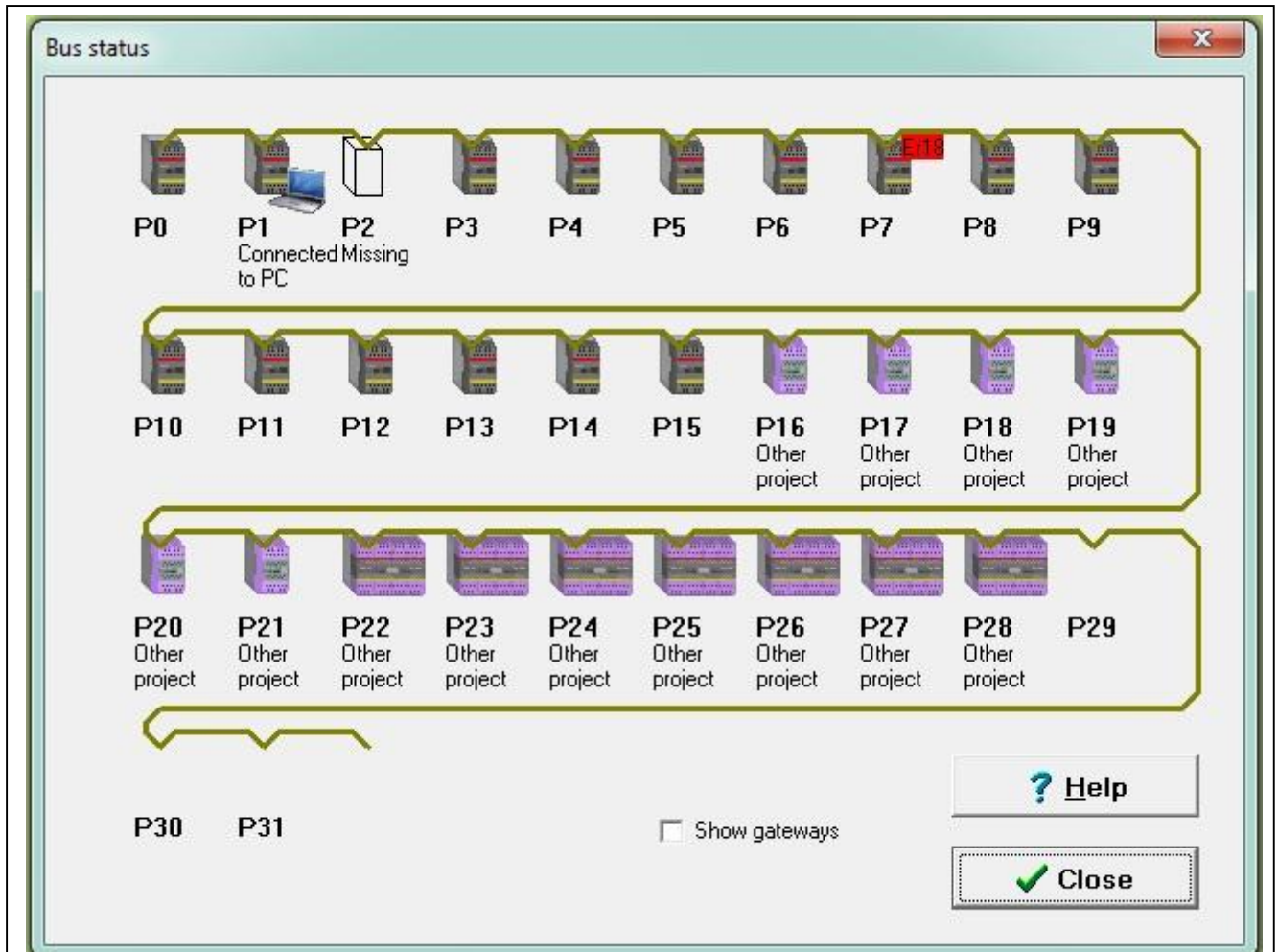

The picture shows a bus with 29 Pluto:s divided in two or more project files.  
 One project contains Pluto nodes 0...15 meaning that these units are loaded with the same program. Pluto no:1 is connected to the PC. Pluto no:2 is in the project but has no connection with the bus. Pluto no:7 has an error.  
 Pluto no: 16...28 are connected to the bus but are not in the same program project as the Pluto connected to the PC.

## Explanation of Bus Status



**Connected to PC** Local Pluto which this computer is connected to.

**Ok** Pluto contains the same project as the local Pluto.

**Wrong project** Either this Pluto has not the same version of the project as the PC connected, or erroneously belong to another project. Plutos belonging to the same project as the local Pluto cannot read I/O or global memory from this unit.

**No response** Unknown project. Probably the system software of the Pluto is too old, it does not report the CRC of the project. Plutos belonging to the same project as the PC connected Pluto cannot read I/O or global memory from this unit.

**Missing** Pluto belong to the same project as the PC connected Pluto, but no unit with the station number is present on the bus.

**Other project** Pluto doesn't belong to the project of PC connected Pluto. Plutos belonging to the same project as the PC connected Pluto can read I/O and global memory from this Pluto regardless of which project it contains.

**Nonexistent** No unit present on the bus. Pluto with this station number is not belonging to the project of the PC connected Pluto.

 **Close**

*Under Help button the following picture with explanation is displayed.*

## 16.7 Seal

In the dialog box "Online info" (see 16.2.2) there is a text line telling "Seal On" or "Seal Off". After download of a program the text "Seal off" is shown. This indicates that the program is changed but not sealed.

The purpose of the seal is just to give an indication that the program is changed and has no influence on the function.

Depending on the licence code, Pluto Manager can be set up with three different alternatives with or without the possibility to write seal.

Alternative 1: Seal function is not available for the user.

Alternative 2: Seal can be loaded separately after program load.

Alternative 3: Seal is automatically loaded by program load.

A user company can then make a system where some people are authorized to review programs and confirm by downloading a seal.

To write a seal: "Tool" à "Write Seal" à A message "Seal written" indicates if success.

## 17 Remote monitoring via Pluto Ethernet Gateway

When using Pluto remote monitor handling the user shall handle cyber and network security by implementing appropriate measures in this area.

### 17.1 Configuring the gateway for remote monitoring

Remote Monitoring of the Pluto PLC program is possible via Pluto Manager over the internet to a Pluto Ethernet Gateway. By default this service is disabled in the gateway, and must be enabled via the PC port connector on the Pluto Ethernet Gateway front. Open Terminal window in Pluto Manager and type “remote”, “y”. It is also possible to add a password. If password is selected, Pluto Manager requires a password before going online.

```
eip_gw>

eip_gw> remote
Enable Pluto remote monitor (y/n)? y
Add password protection for Pluto remote monitor (y/n)? y
Set password for Pluto remote monitor,
Password : *****
Password : *****
Password changed!
To make changes active, restart the unit.
Reset gateway? (y/n) y
Reset...
eip_gw>
```

It is possible to view the current IP address setting with the “bw” command, and to change it with the “ipaddr” command (see Pluto Ethernet Gateway Manual).

### 17.2 Remote monitoring

In Pluto Manager, under Preferences/Communication Port, select “Network” and fill in the IP address for the Gateway.

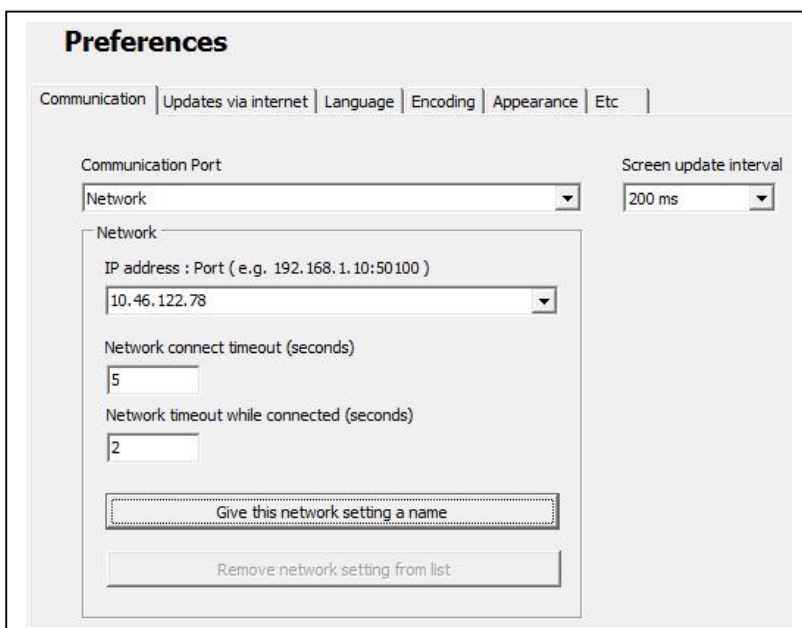

The screenshot shows the 'Preferences' dialog box in Pluto Manager, with the 'Communication' tab selected. The 'Communication Port' is set to 'Network'. The 'Screen update interval' is set to '200 ms'. Under the 'Network' section, the 'IP address : Port ( e.g. 192.168.1.10:50100 )' is set to '10.46.122.78'. The 'Network connect timeout (seconds)' is set to '5', and the 'Network timeout while connected (seconds)' is set to '2'. There are two buttons at the bottom: 'Give this network setting a name' and 'Remove network setting from list'.

The IP address can be given a name by clicking “Give this network setting a name”.

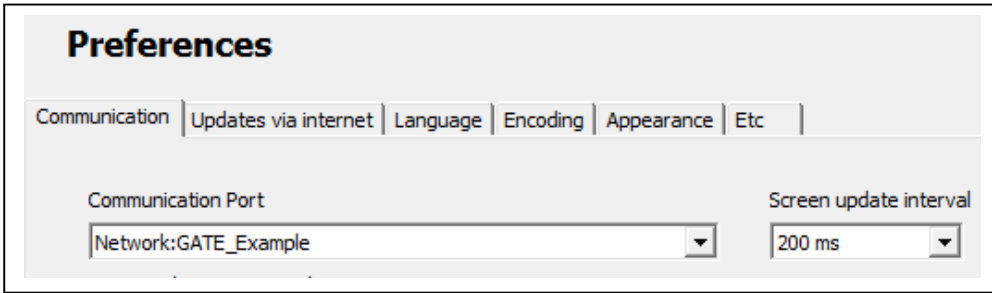

Connection to the gateway should now be established. Click for instance “Bus St” in Pluto Manager.

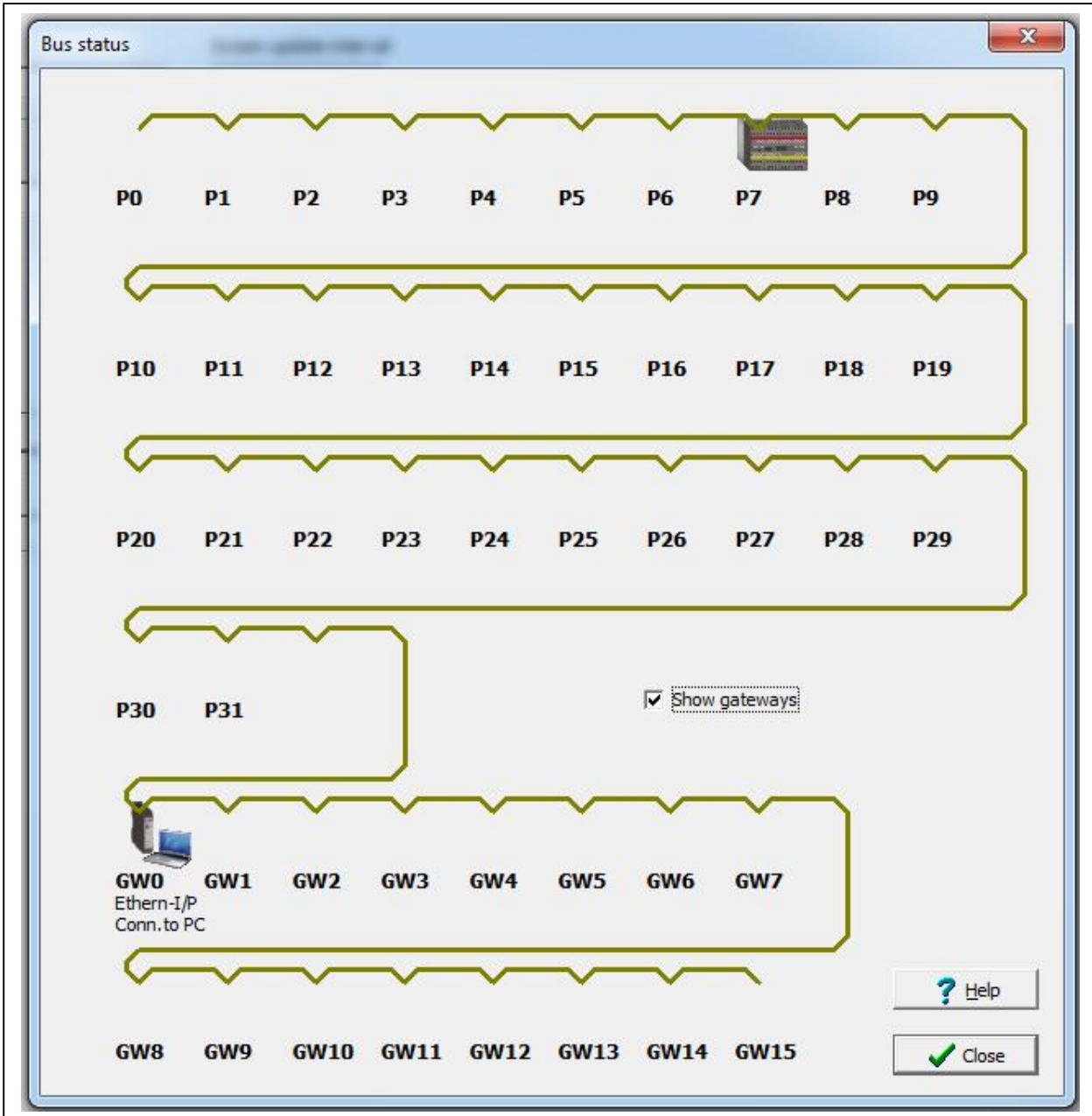



It is also possible to go Online and monitor the PLC program, or to open Terminal Window over the network connection. When Tools/Terminal Window is selected, a choice between “Monitoring (user)” and Controlling (admin)” is presented. Select “Monitoring (user)”. If password protection has been selected, this password will need to be entered.

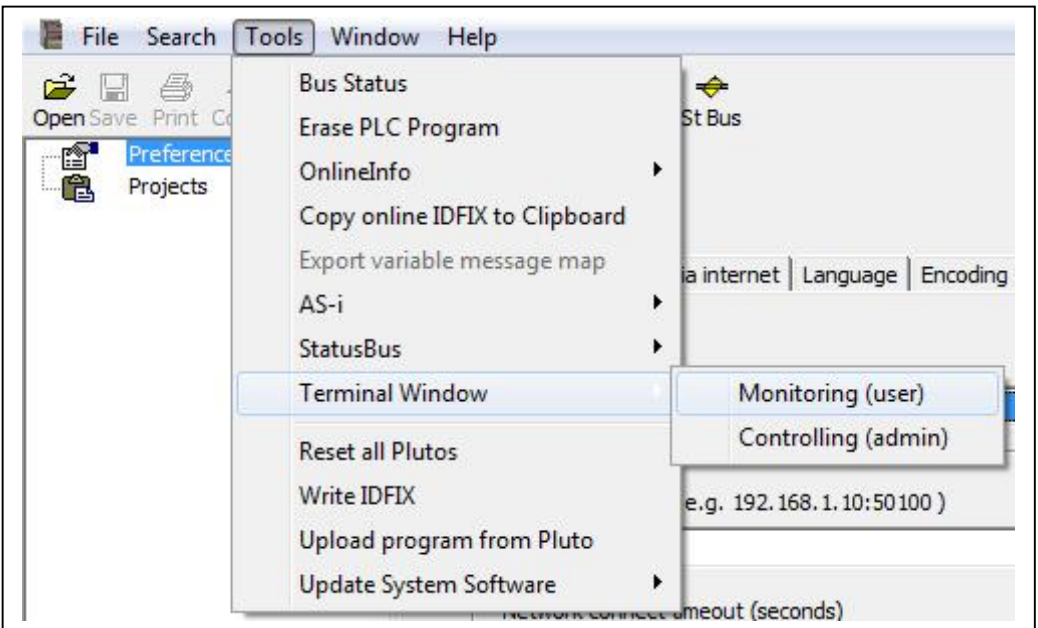

If password protection is selected in the gateway Pluto Manager asks for a password.



After entering the password the login will be valid, and the password will not be requested again, until Pluto Manager is closed down.



## 18 Create function block libraries

For the advanced user Pluto Manager offers the possibility to create libraries with new function blocks. In the following example a “Two out of three” function block will be made.

Right click on Projects, click New Library.

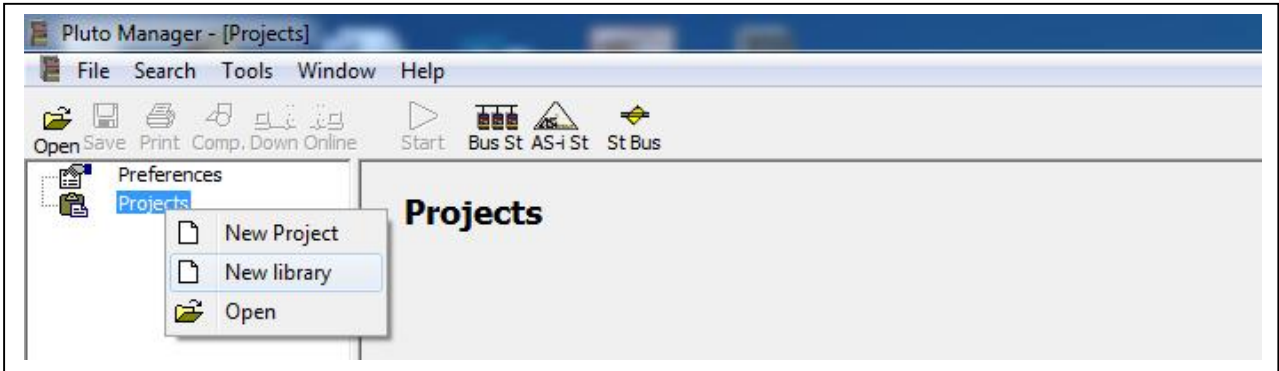

Right click on Library, click New function block, and enter the name of the function block.

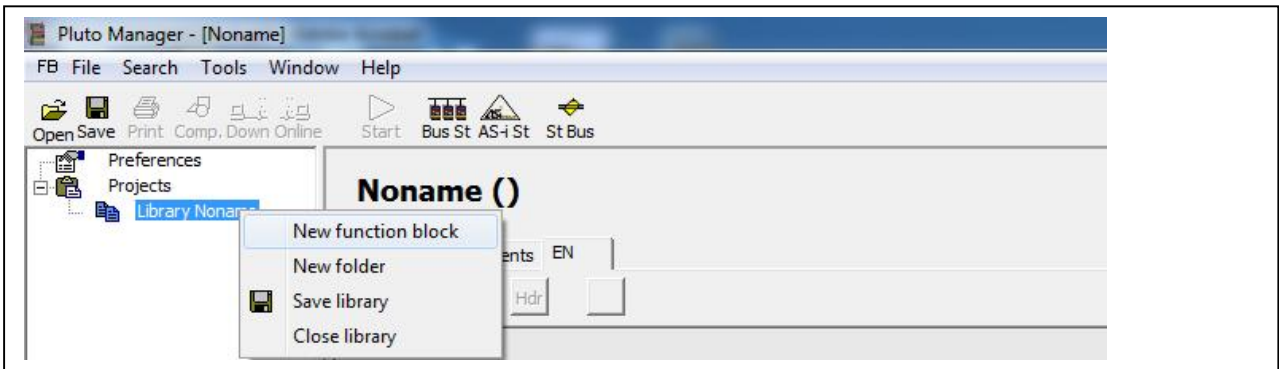

Click “Variables” and fill in the parameters for inputs and outputs for the block under “Function parameters”.

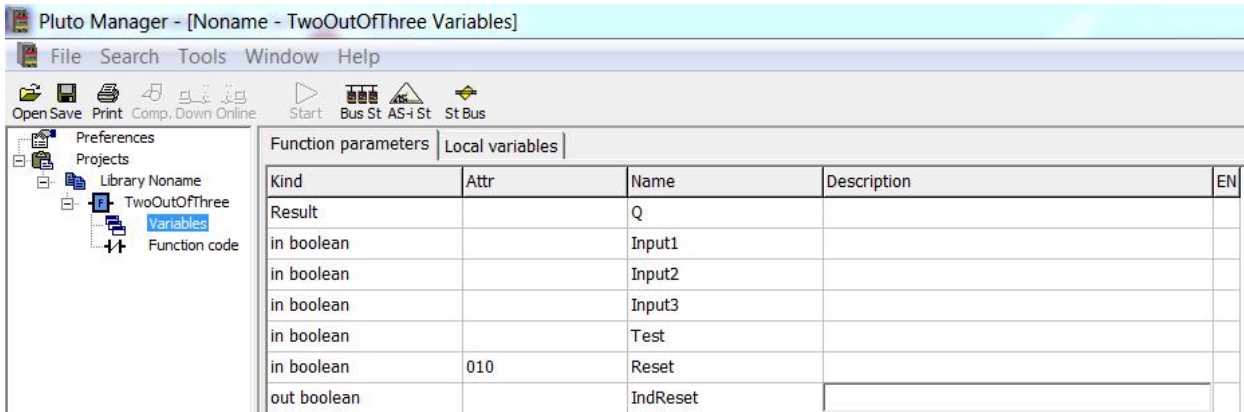

Kind	Attr	Name	Description	EN
Result		Q		
in boolean		Input1		
in boolean		Input2		
in boolean		Input3		
in boolean		Test		
in boolean	010	Reset		
out boolean		IndReset		

*Note: Attr=010 will display a pulse symbol on the input of the block.*

“Local variables” are for variables which exist only inside the function block.

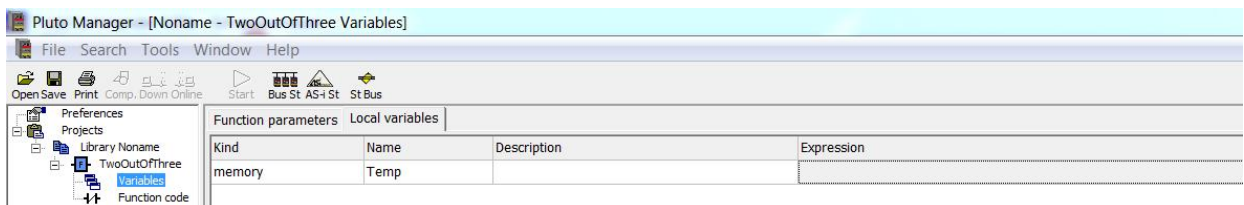

Kind	Name	Description	Expression
memory	Temp		

Click on the function block name, in this case “TwoOutOfThree”. Here it is possible to enter a block description that will be displayed in the function guide (here in the example the English description).

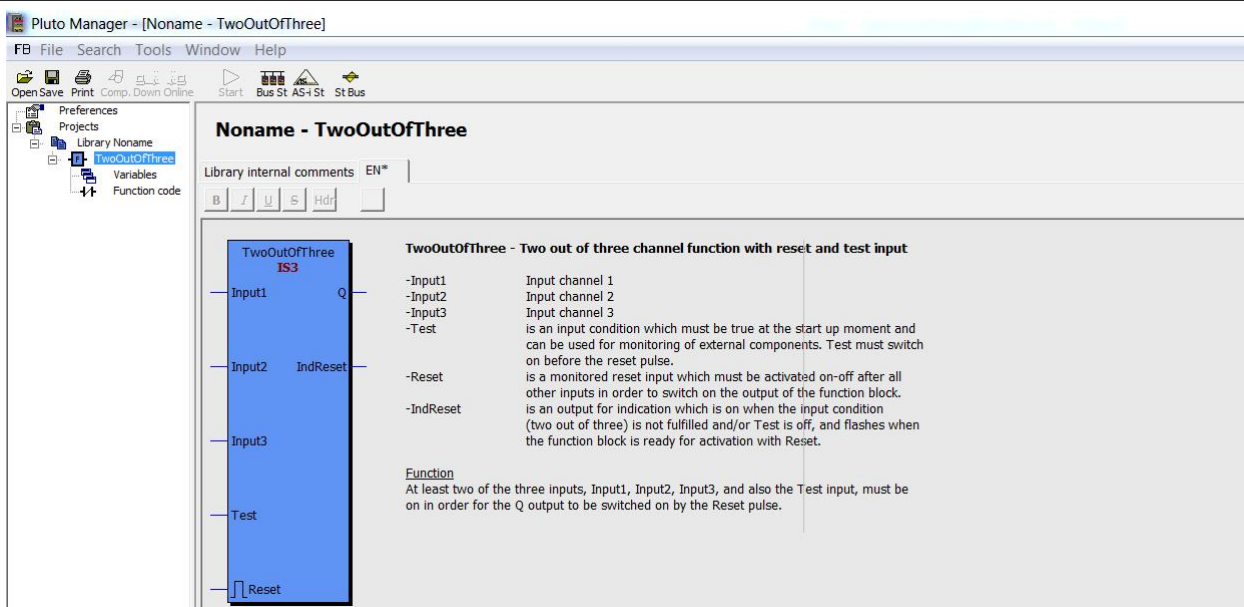

**Noname - TwoOutOfThree**

Library internal comments EN\*

**TwoOutOfThree - Two out of three channel function with reset and test input**

- Input1 Input channel 1
- Input2 Input channel 2
- Input3 Input channel 3
- Test is an input condition which must be true at the start up moment and can be used for monitoring of external components. Test must switch on before the reset pulse.
- Reset is a monitored reset input which must be activated on-off after all other inputs in order to switch on the output of the function block.
- IndReset is an output for indication which is on when the input condition (two out of three) is not fulfilled and/or Test is off, and flashes when the function block is ready for activation with Reset.

**Function**  
At least two of the three inputs, Input1, Input2, Input3, and also the Test input, must be on in order for the Q output to be switched on by the Reset pulse.

It is possible to use other function blocks inside the function block code. The function library, in this case the standard library func06.fps, must be specified on the library configuration page. Here it can also be specified which block description languages to be used.

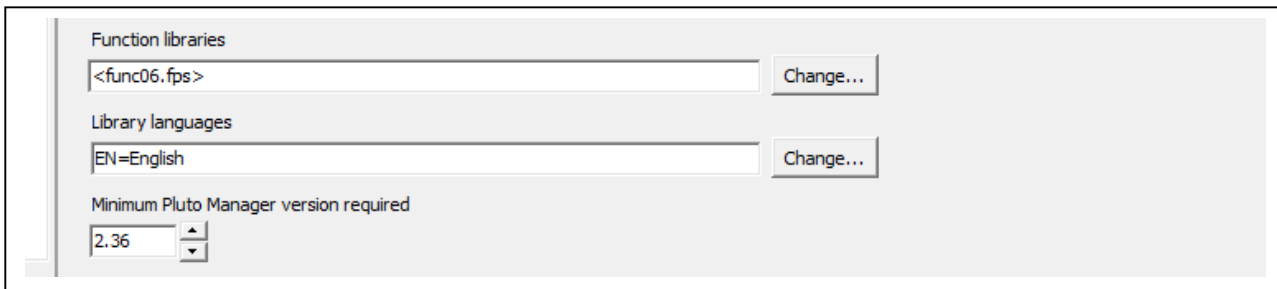

Then click on "Function Code" to program the function block.

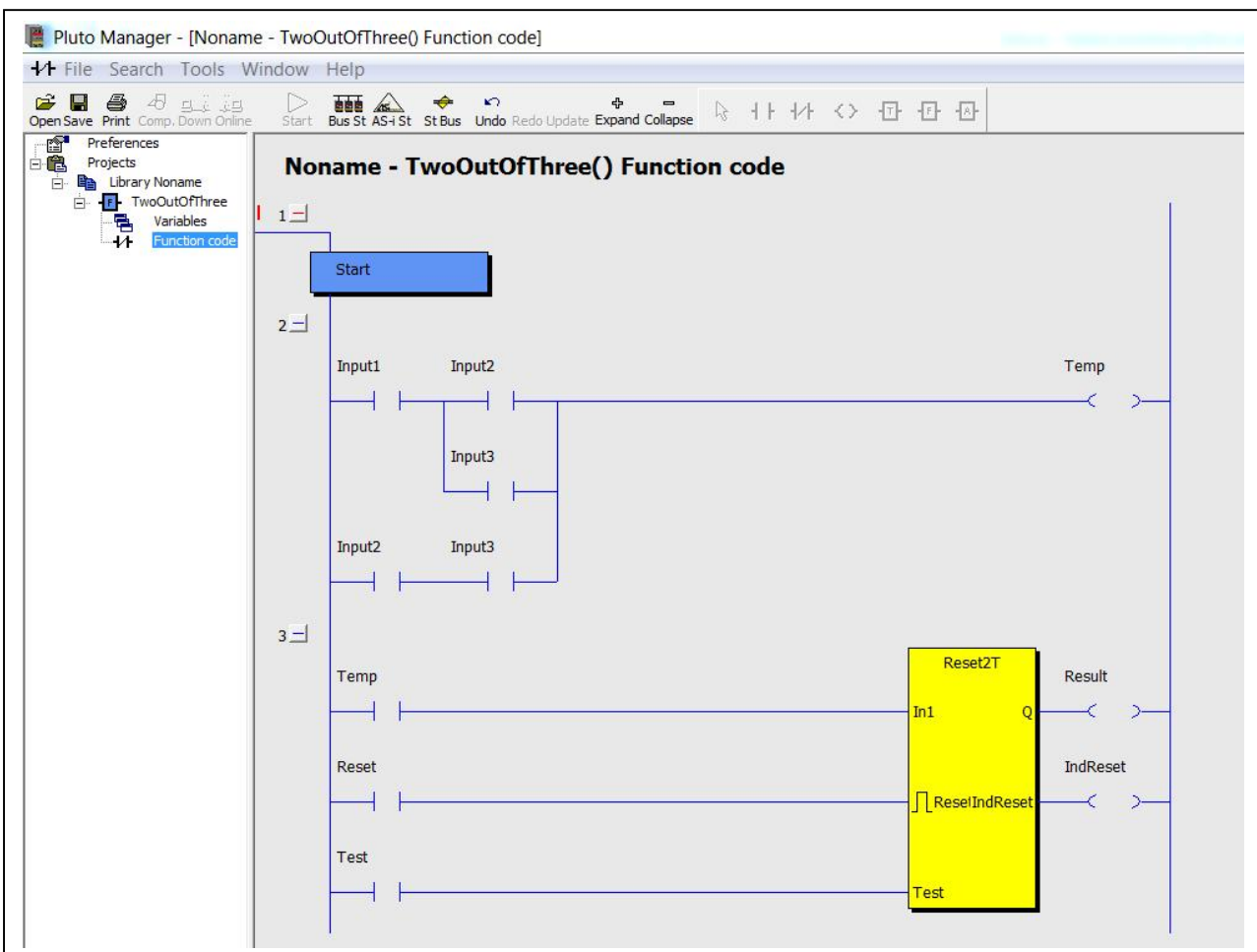

Save the library as Example.fps

Create a Pluto project to test the function block. Specify user library Example.fps in the project. Add a Pluto to the project and specify IDFIX. Add the new function block to the PLC code. Add inputs and outputs to the block and configure the I/O's.

Compile the project.

It is now possible to open the function block from the Pluto project by right clicking on the function block and clicking on "open function block".

It is also possible to monitor inside the function block online: (always click on a project window before going online).

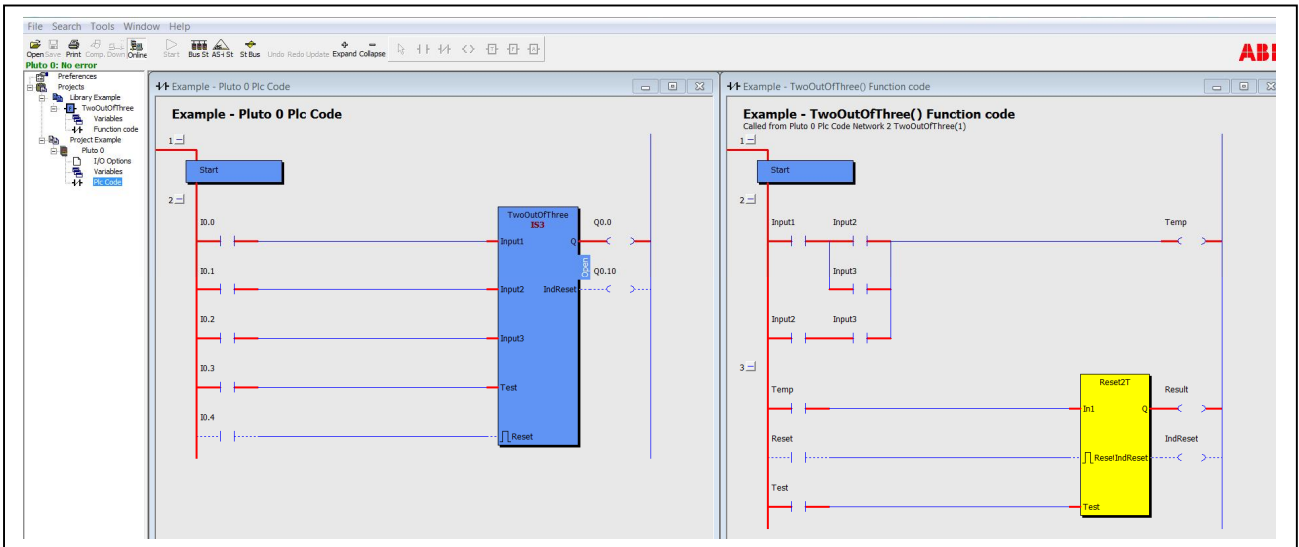

Note that at the top of the function block code the function block instance is displayed, where it can be verified that the function block is called from the correct place in the code.

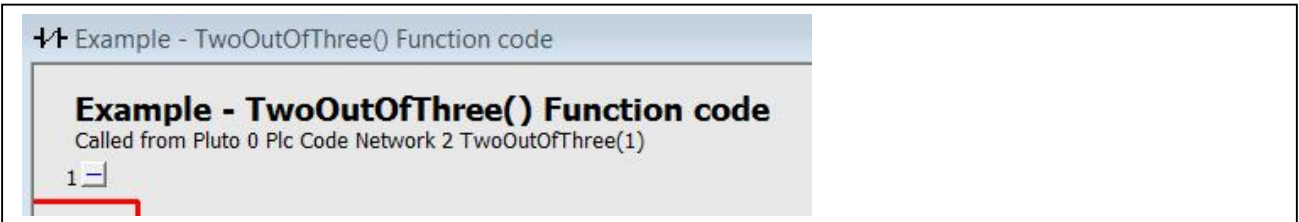

Hover the mouse of the contact/coil to see which I/O that is connected to the active instance of the function block.

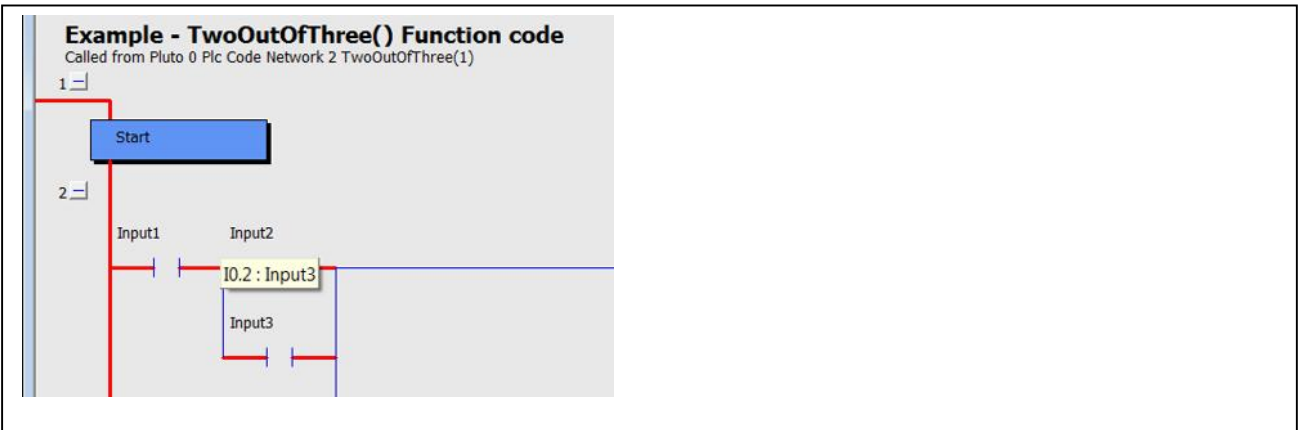

## 18.1 Sequences in function blocks

With Pluto OS version 3.8 and higher it is possible to have sequences and sequence steps in function blocks. Sequences and sequence steps works in the same way as for the PLC program itself. With this feature it becomes possible to encapsulate a complete application, or part of an application, in the form of a function block. The end user can then select which I/O:s to use. The user can also easily add extra emergency stops and sensors to the block inputs.

The previous "Two out of three" example function block is extended with a sequence that handles LED indication. Load the previously created function library. Right click on the function name "TwoOutOfThree" and select "New sequence". Name the new sequence "Indication". Program the indication as below. The "compiler directives" (circled in red) are described in the next chapter.

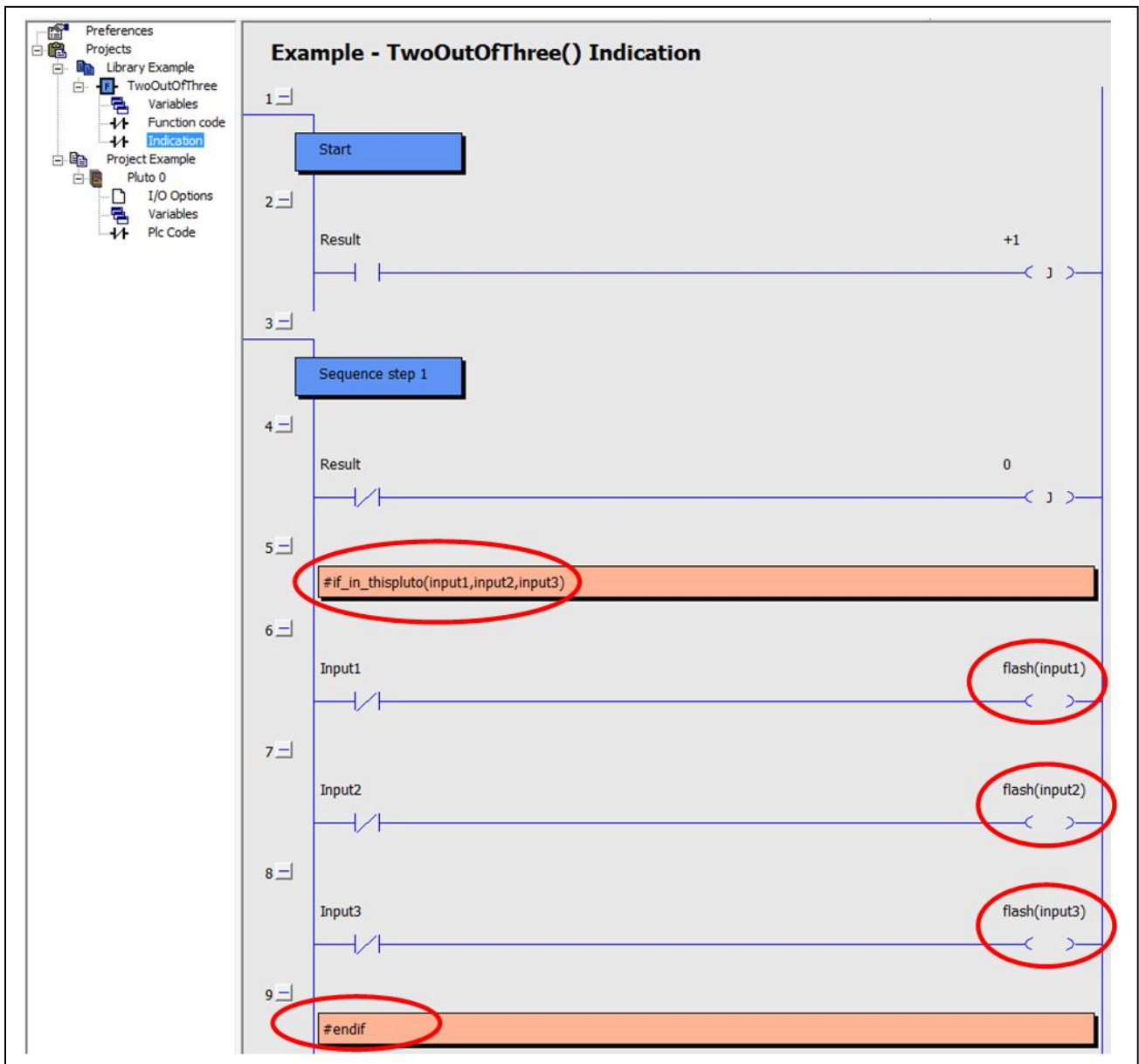

## 18.2 Compiler directives

In the function block code compiler directives can be inserted.

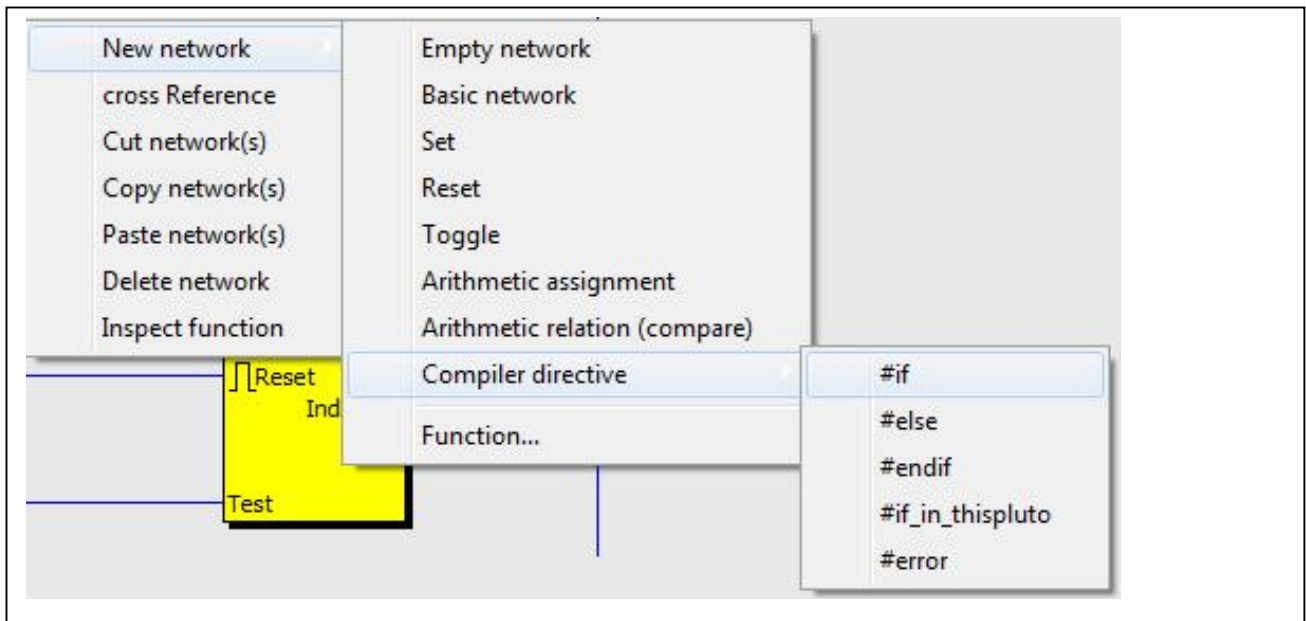

If the constant parameter Counter is set to high a compilation error is issued:

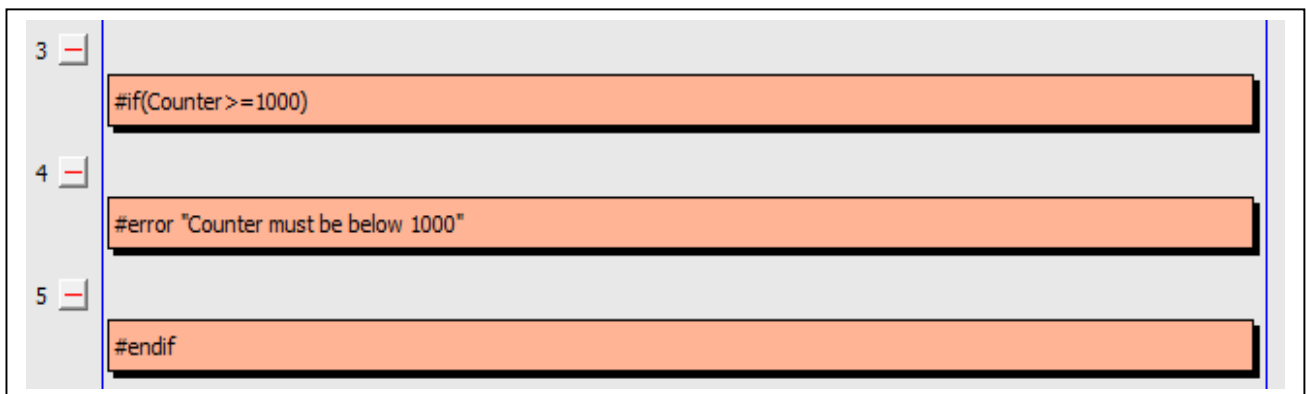

It is possible to generate different code depending on block parameters.

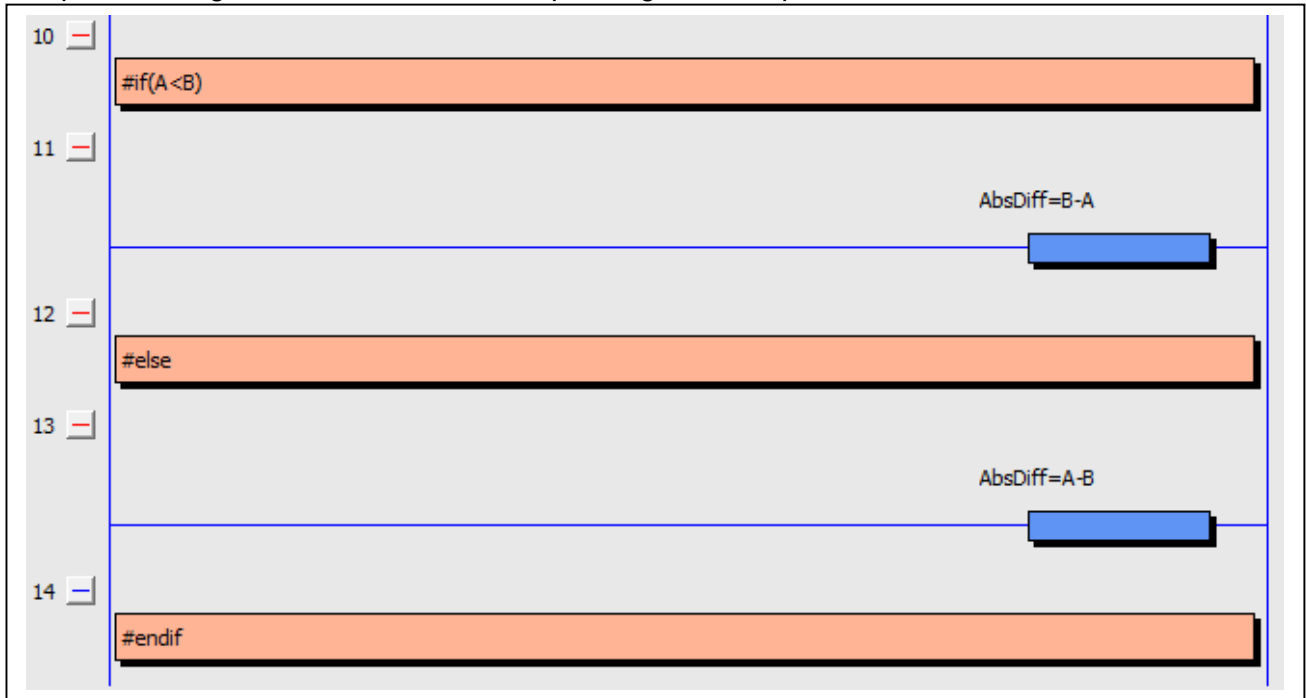

If the inputs Input1 and Input2 are both in the local Pluto, the LED:s on the Pluto front panel are flashing when Error is set. If the inputs are located in another Pluto, or if they are expressions in the calling program no code is generated.

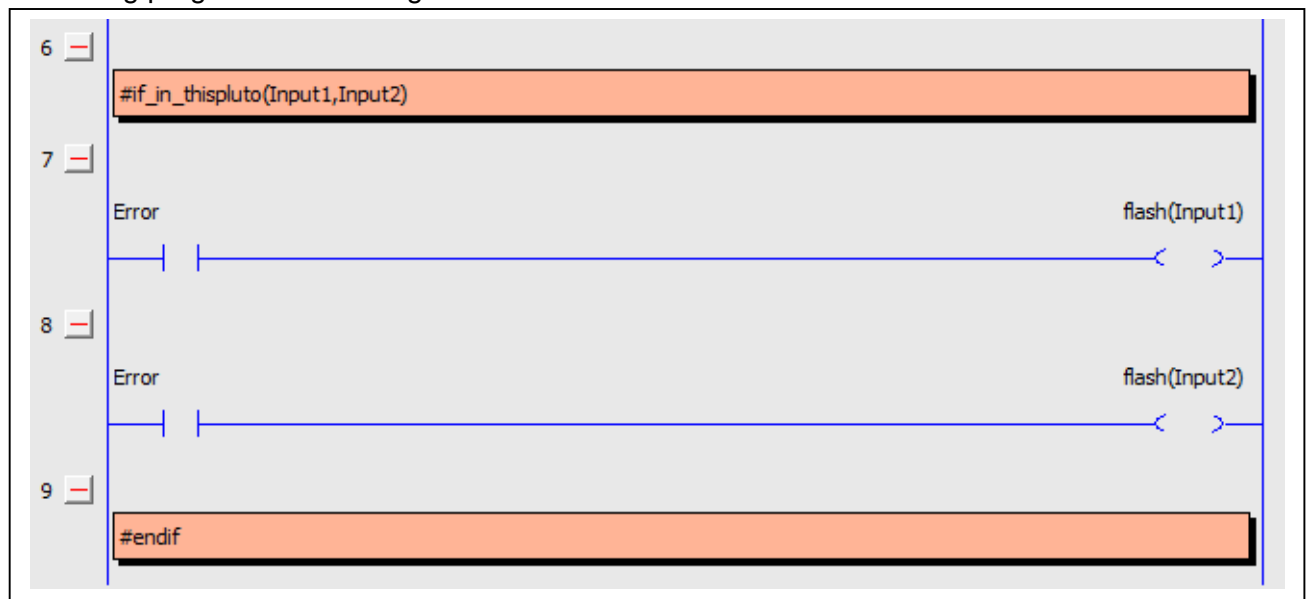

To name the outputs “flash(Input1)” and “flash(Input2)” just type the name in the Symbolic Variable Name field.

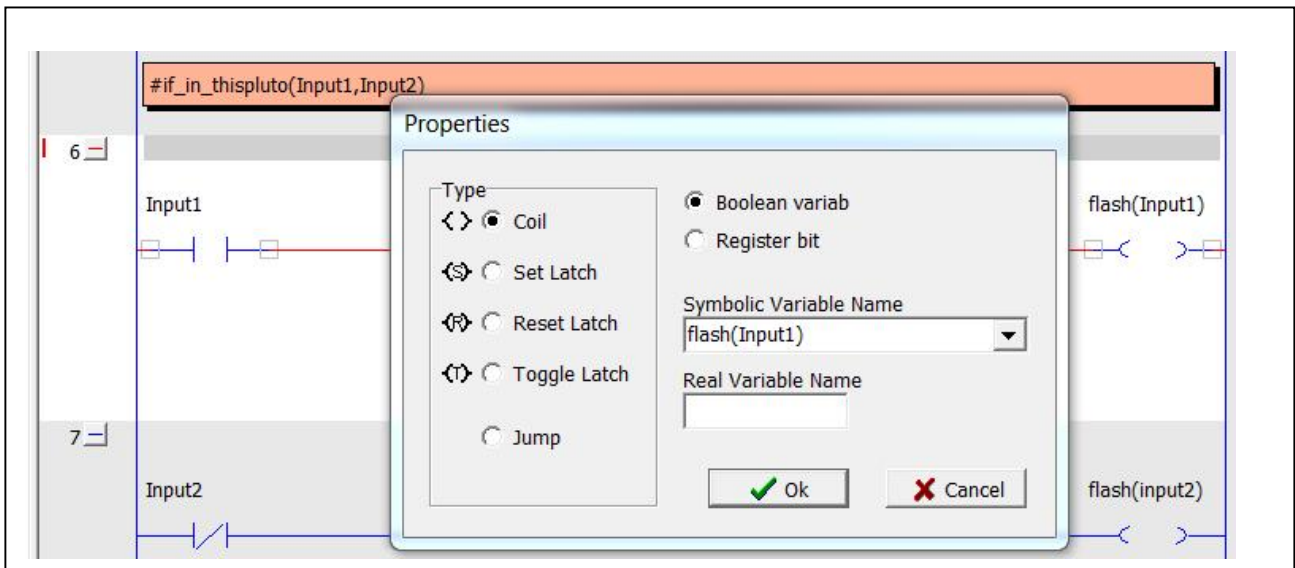

### 18.3 Other new functions

- Possibility to write function block description in several languages.
- The descriptions can contain pictures.
- Possibility to password protect libraries.
- Possibility to specify an output as NonSafe.

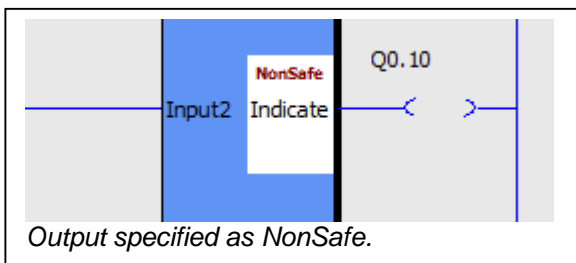



# Part 2

## Programming language

**NOTE:** *Instructions and functions written in Italics are for Pluto with “instruction set 3” only. (See 3.6.1 Instruction set 2 / Instruction set 3 in Part 1 of this manual.)*

### 1 Bit-instructions

#### 1.1 Addressing of bit-operands

In PLUTO programming language I/O and memories are addressed as [*I/O-type*][*unit no.*].[*I/O no.*].

At most 32 PLUTO-units, numbered 0 – 31, can be interconnected via the Bus.

The table below shows the principle addressing for Pluto. (Mainly Pluto A20 family)

I/O type:	I/O designation Pluto 0	I/O designation Pluto 1	.....	I/O designation Pluto 31
Inputs	I0.0 I0.1 . . I0.17	I1.0 I1.1 . . I1.17	... .. ... .. ... .. ... .. ... ..	I31.0 I31.1 . . I31.17
Outputs	Q0.0 Q0.1 . . Q0.17	Q1.0 Q1.1 . . Q1.17	..... ... .. ... .. ... .. ... ..	Q31.0 Q31.1 . . Q31.17
Memories	M0.0 M0.1 . . M0.599	M1.0 M1.1 . . M1.599	..... ... .. ... .. ... .. ... ..	M31.0 M31.1 . . M31.599
Global memories	GM0.0 GM0.1 . . GM0.11	GM1.0 GM1.1 . . GM1.11	..... ... .. ... .. ... .. ... ..	GM31.0 GM31.1 . . GM31.11
<i>Register bits*</i>	<i>R0.0.0... R0.0.15</i> <i>R0.1.0... R0.1.15</i> . . <i>R0.149.0... R0.149.15</i>	<i>R1.0.0... R1.0.15</i> <i>R1.1.0... R1.1.15</i> . . <i>R1.149.0...R1.149.15</i>	..... ... .. ... .. ... .. ... ..	<i>R31.0.0... R31.0.15</i> <i>R31.1.0... R31.1.15</i> . . <i>R31.149.0... R31.149.15</i>

*\*Instruction set 3 only. Register bits can be addressed individually and they are referred as R<Pluto>.<reg>.<bit>.*

Example:

Q10.1                    Ū                    Addressing of output 1 on PLUTO no. 10

Following alternatives are also accepted: Q10.01 or Q10.0001 or Q10.1

The table below shows the principle addressing for Pluto AS-i slave inputs and outputs.  
(This is described further in Chapter 7 AS-i bus functions.)

I/O type:	I/O designation Pluto 0	I/O designation Pluto 1	.....	I/O designation Pluto 31
AS-i inputs (Safe)	ASi0.1 ASi0.2 . . ASi0.31	ASi1.1 ASi1.2 . . ASi1.31	... .. ... .. ... .. ... .. ... ..	ASi31.1 ASi31.2 . . ASi31.31
AS-i inputs Nonsafe standard slaves	ASi0.1.1... ASi0.1.4 ASi0.2.1... ASi0.2.4 . . ASi0.31.1... ASi0.31.4	ASi1.1.1... ASi1.1.4 ASi1.2.1... ASi1.2.4 . . ASi1.31.1... ASi1.31.4	... .. ... .. ... .. ... .. ... ..	ASi31.1.1... ASi31.1.4 ASi31.2.1... ASi31.2.4 . . ASi31.31.1... ASi31.31.4
AS-i inputs Nonsafe B-slaves	ASi0.1B.1... ASi0.1B.4 ASi0.2B.1... ASi0.2B.4 . . ASi0.31B.1... ASi0.31B.4	ASi1.1B.1... ASi1.1B.4 ASi1.2B.1... ASi1.2B.4 . . ASi1.31B.1... ASi1.31B.4	... .. ... .. ... .. ... .. ... ..	ASi31.1B.1... ASi31.1B.4 ASi31.2B.1... ASi31.2B.4 . . ASi31.31B.1... ASi31.31B.4
AS-i outputs Nonsafe standard slaves	ASq0.1.1... ASq0.1.4 ASq0.2.1... ASq0.2.4 . . ASq0.31.1... ASq0.31.4	ASq1.1.1... ASq1.1.4 ASq1.2.1... ASq1.2.4 . . ASq1.31.1... ASq1.31.4	... .. ... .. ... .. ... .. ... ..	ASq31.1.1... ASq31.1.4 ASq31.2.1... ASq31.2.4 . . ASq31.31.1... ASq31.31.4
AS-i outputs Nonsafe B-slaves	ASq0.1B.1... ASq0.1B.4 ASq0.2B.1... ASq0.2B.4 . . ASq0.31B.1... ASq0.31B.4	ASq1.1B.1... ASq1.1B.4 ASq1.2B.1... ASq1.2B.4 . . ASq1.31B.1... ASq1.31B.4	... .. ... .. ... .. ... .. ... ..	ASq31.1B.1... ASq31.1B.4 ASq31.2B.1... ASq31.2B.4 . . ASq31.31B.1... ASq31.31B.4

## 1.2 Register bits (Instruction set 3 only)

With instruction set 3 it is possible to perform operations on individual register bits. To set a bit in a register select “New Network” and “Set”.

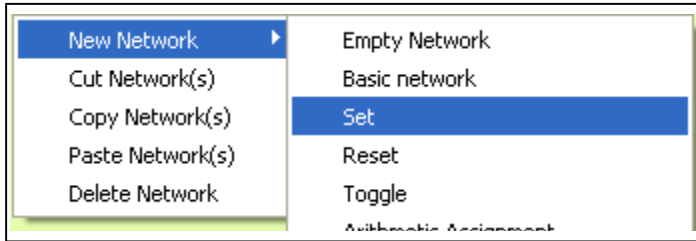

Select “Register bit”, choose register and bit number and click Ok.

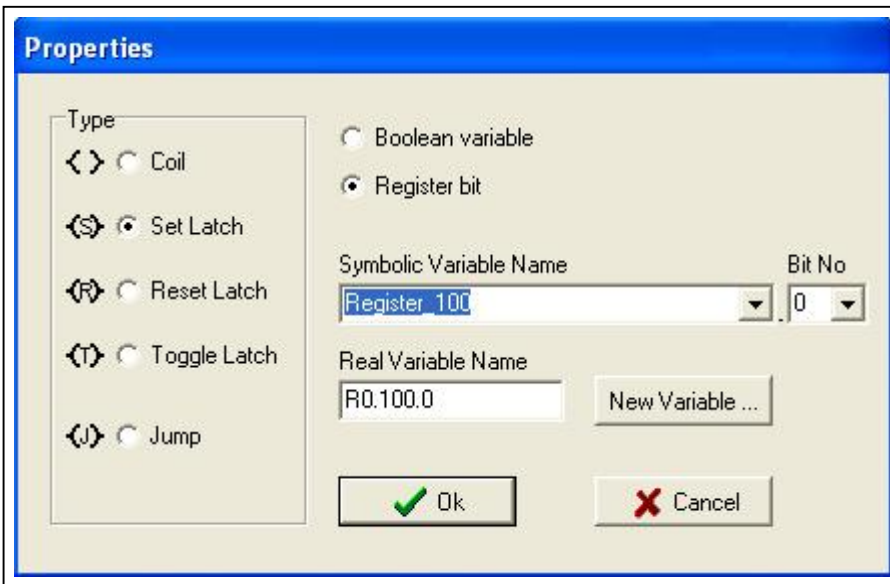

Example:

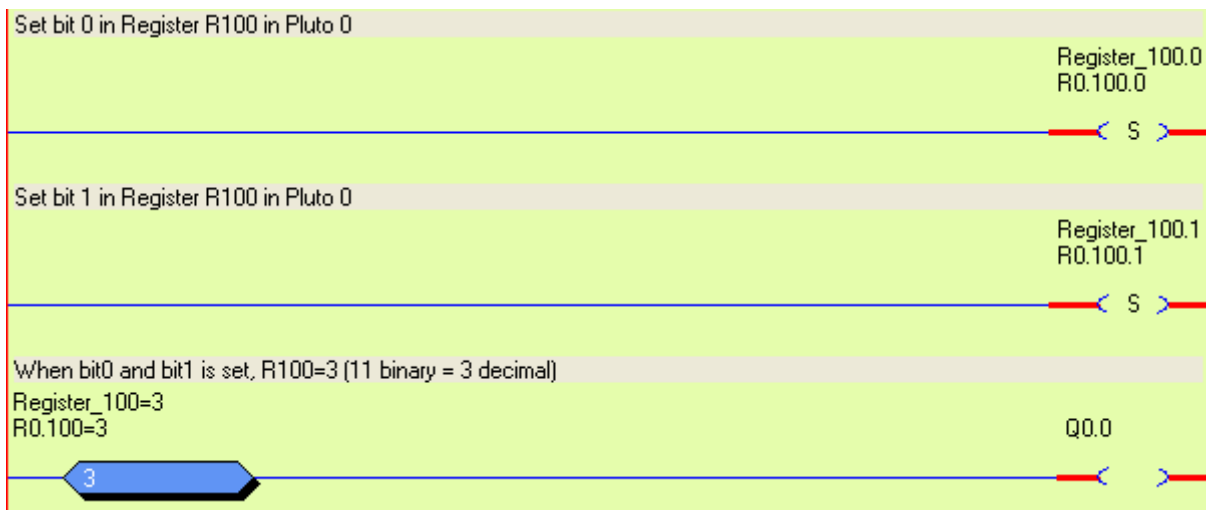

In this example bit0 and bit1 in register R100 in Pluto 0 is set. The value in R100 will be 3 which corresponds to the binary value 11 (the two least significant bits set).

### 1.3 Boolean instructions

PLUTO programming language follows the rules for ladder programming of IEC 1131-3 when programming with Pluto Manager.

By programming in text form using an text editor the programming language follows the Boolean laws and utilises AND, OR, NOT and EXECUTION -commands.

Program syntax in text form:

Instruction:	Program syntax:
AND	*
OR	+
NOT	/
EXECUTION	=

Example:

In ladder form:

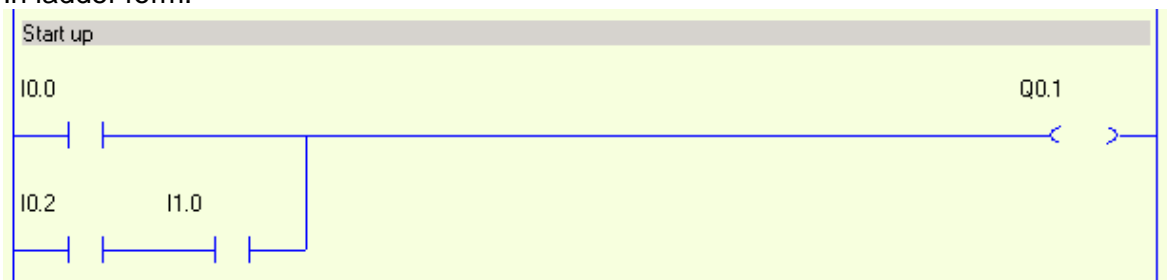

Equivalent text form:

$Q0.1 = I0.0 + I0.2 * I1.0$  ; Start up  
; (semicolon) defines start of program comments.

Explanation: Output Q0.0 is on when input I0.0 or both of I0.2 and I1.0 is on ('1').

Example with negation:

In ladder form:

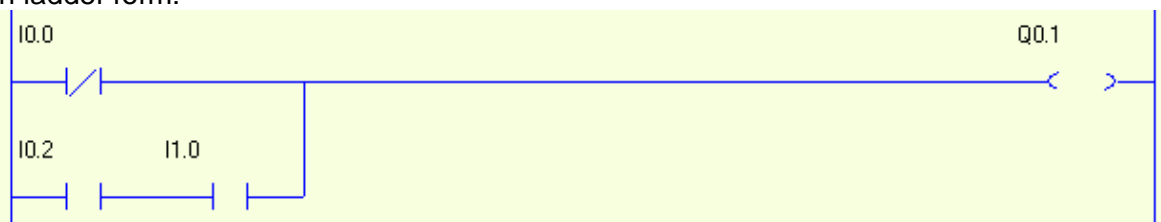

Equivalent text form:

$Q0.1 = /I0.0 + I0.2 * I1.0$

According to the boolean laws AND-instructions (\*) are executed before OR-instructions (+). By using brackets the instruction order can be changed.

Examples:

$$Q0.1 = I0.0 + I0.2 * I1.0 * I0.1$$

Equivalent ladder:

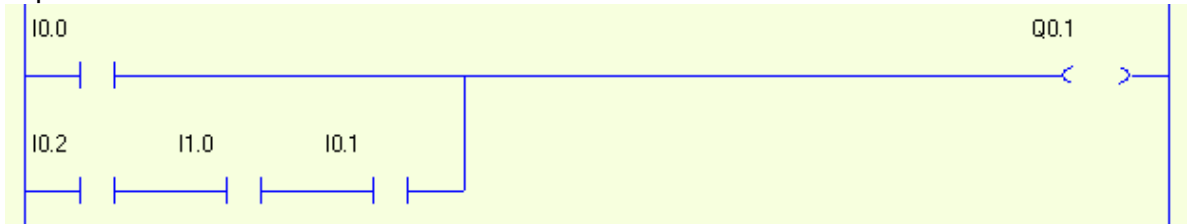

Example with use of brackets

$$Q0.1 = (I0.0 + I0.2 * I1.0) * I0.1$$

Equivalent with:

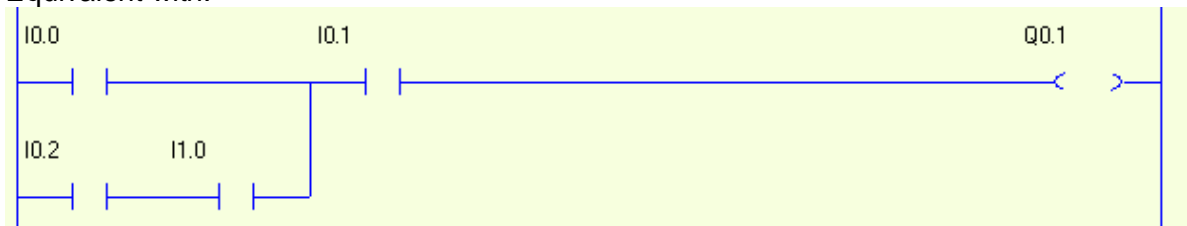

**NOTE:** In text form the use of spaces have no influence.

## 1.4 Edge detection

Edge detection can be used on single operands. The EDGE-function enables detection of both positive and negative edges. Relevant program syntax follows in the table below:

Positive edge:

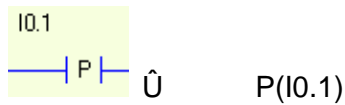

Negative edge:



**Function:** When an edge is detected a logical “1” is held during a complete program scan cycle.

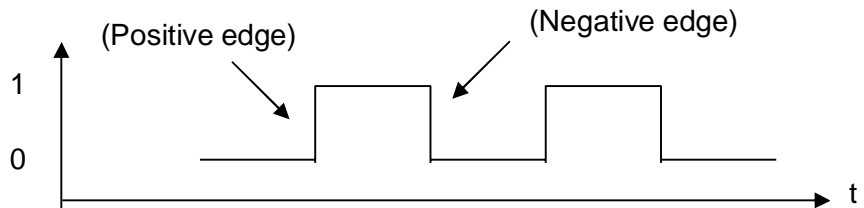

Example:

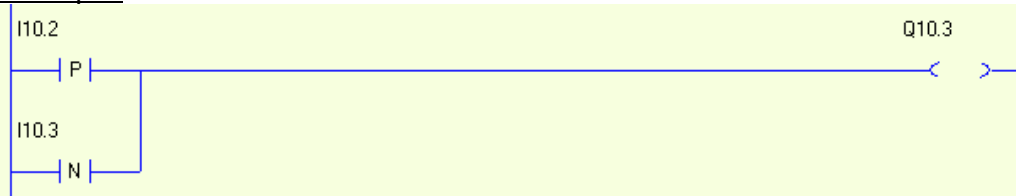

Equivalent text form:

$Q10.3 = P(I10.2) * P(/I10.3)$   $\hat{U}$  Output 3 on PLUTO no. 10 is set HIGH when positive edge is detected on input 2 on PLUTO no. 10

### 1.4.1 Inverted edge detection (Instruction set 3 only)

This function is the inversion of the normal edge function so that the result is normally “1”, and when an edge is detected logic “0” is held during one PLC cycle.

Not Positive edge:



Not Negative edge:



Example:

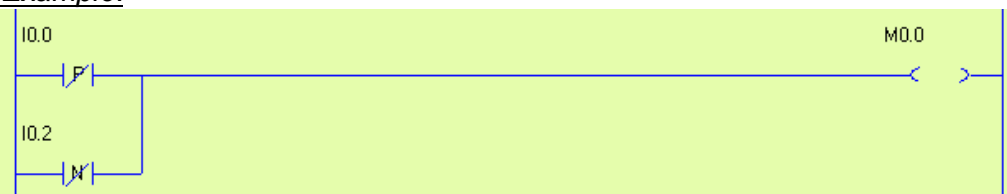

M0.0 is normally high (“1”). By a positive edge on I0.0 or negative edge on I0.2, M0.0 is “0” during one PLC cycle.

## 1.5 Latch function

By use of the Latch function an output or a memory-cell is given a self-hold/memory function.

Latch function:	Program syntax:
SET/Latch on	S(Q0.1)
RESET/Latch off	R(Q0.1)

When an output/memory-cell is set HIGH by the SET-instruction, the output/memory-cell will remain HIGH although the previous condition-statement no longer is TRUE. The output/memory-cell can be set LOW by use of the RESET-instruction.

Example:

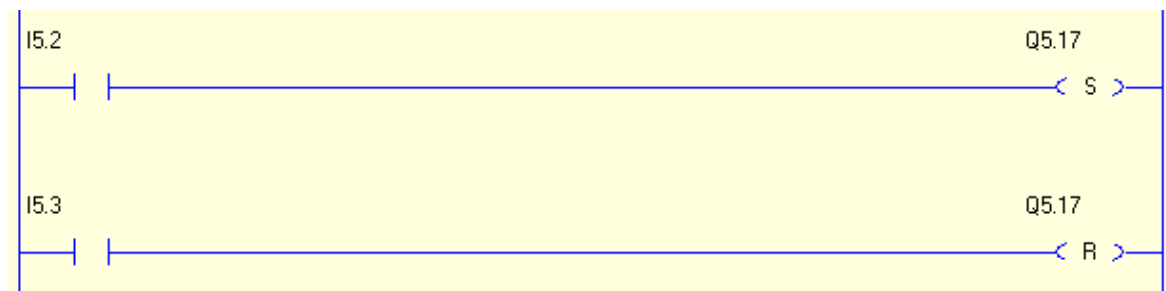

Equivalent text form:

S(Q5.17) = I5.2

R(Q5.17) = I5.3

**Function:** Output 17 on PLUTO no. 5 is set HIGH when input 2 on PLUTO no. 5 is set HIGH. The output remains HIGH until it is RESET by setting input 3 on PLUTO no. 5 HIGH.

## 1.6 Toggle function

The Toggle function toggles the state of an operand (Q, M or GM).

Toggle function:	Program syntax:
Toggle state	T(Q0.1)

Example:

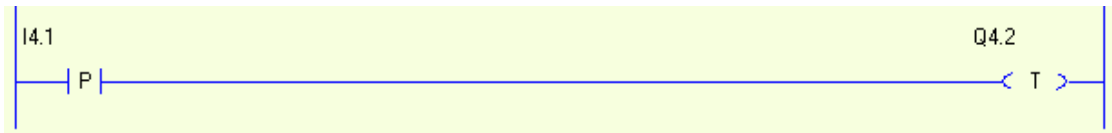

Equivalent text form:

$T(Q4.2) = P(I4.1)$

**Function:** Toggle of output 2 on PLUTO no. 4 changes state from 0 -> 1 or 1 -> 0 on positive edge of input 1 on PLUTO no. 4.

**NOTE:** In this example edge instruction is used to avoid that Q4.2 toggles more than once. Otherwise the output will toggle ON/OFF every PLC cycle.



## 1.7 Timers

PLUTO has 50 timers that all can be used simultaneously in an active sequence step (see sequences). The timers have a resolution of 10 ms and can be defined in the time-interval 0.01 – 655.35 s.

Timer:	Value:	Program syntax:	Old Program syntax:
TON	0.01- 655.35 s.	<b>TON</b> (nnSnn)	<b>T</b> (nnSnn)
TPS	0.01- 655.35 s.	<b>TPS</b> (nnSnn)	<b>IT</b> (nnSnn)
TOF*	0.01- 655.35 s.	<b>TOF</b> (nnSnn)	-

\*Instruction set 3 only

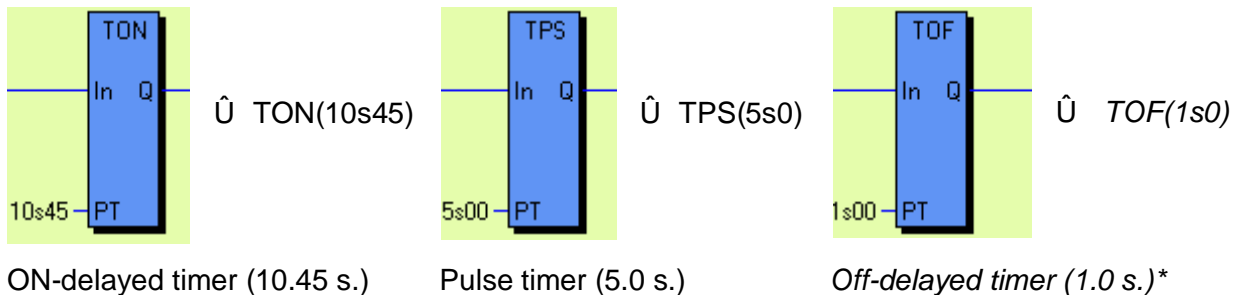

The “s” -symbol corresponds to decimal sign

**Function:** There are three types of timers: ON-delayed, pulse timers and *Off-delayed timer*. (*Off-delayed timer is only defined with instruction set 3 selected.*)

ON-delayed timers (TON) start when the boolean instructions on the left side of the timer instruction is TRUE. When the specified time is elapsed, and as long as the input stays high, the timer is TRUE (“1”).

Pulse timers (TPS) are activated in the same way but they are TRUE (“1”) from start and go FALSE (“0”) when the time has elapsed, or when the input goes low.

*Off-delayed timers (TOF) are TRUE (“1”) when the boolean instructions on the left side of the timer instruction is TRUE. When the input goes FALSE (“0”) the timer starts to count down, and when the specified time is elapsed the timer goes FALSE (“0”).*

Exemple:

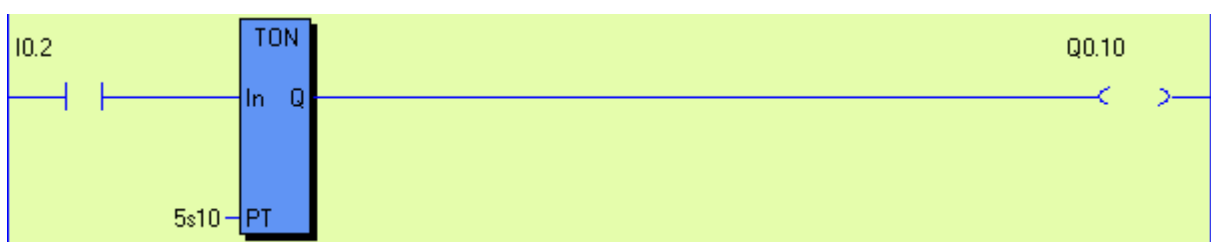

Equivalent text form:       $Q0.10 = I0.2 * TON(5s10)$

**Function:** When input I0.2 is set HIGH the timer with time-delay of 5.10s is activated. Output Q0.10 is set HIGH when the time is elapsed.

Example:

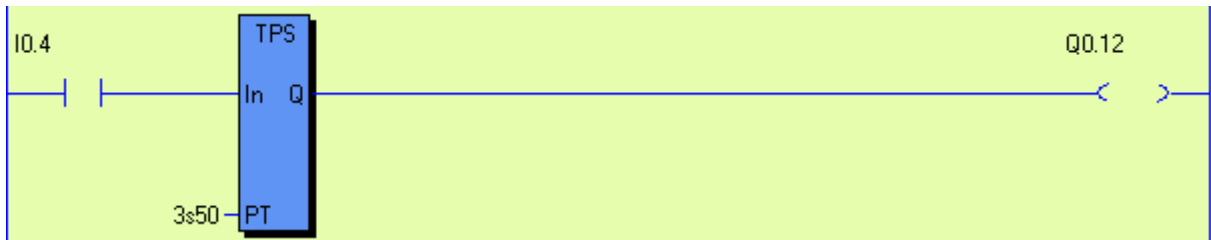

Equivalent text form:  $Q0.12 = I0.4 * TPS(3s5)$

**Function:** When input I0.4 is set HIGH the timer output and then output Q0.12 is immediately set.

After a delay of 3.5 s the timer switches output Q0.12 off.

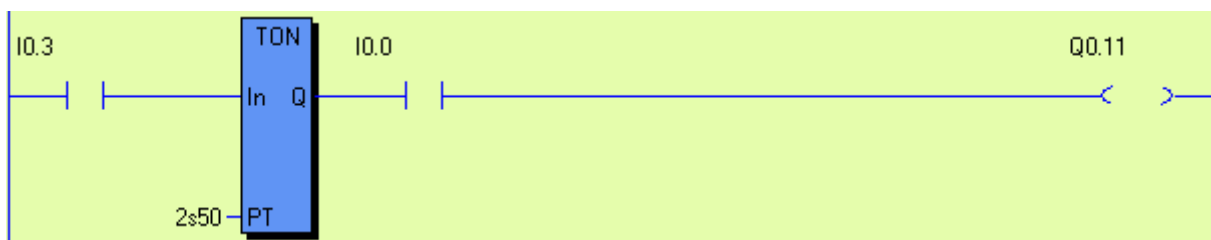

Equivalent text form:  $Q0.11 = I0.3 * TON(2s5) * I0.0$

**Function:** When input I0.3 is set HIGH the timer is activated.

After a delay of 2.5 s and if input I0.0 is HIGH, output Q0.11 switches on.

Note that the expression after to the right of the timer (I0.0) has no influence on the timer.

Example:

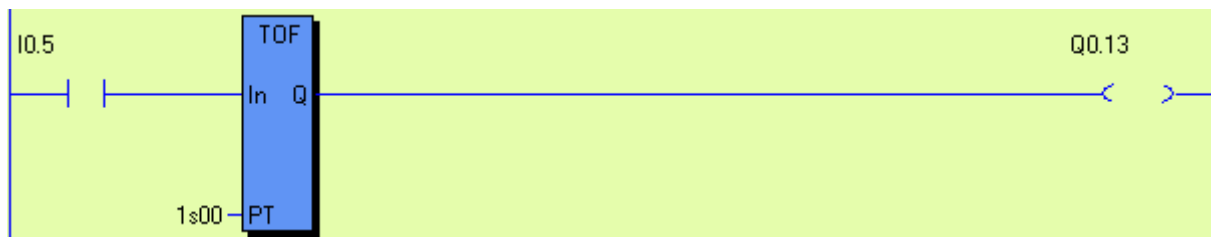

Equivalent text form:  $Q0.13 = I0.5 * TOF(1s00)$

**Function:** When input I0.5 is set HIGH the output Q0.13 is immediately set. When input I0.5 goes LOW the timer with time-delay of 1.00s is activated. Output Q0.13 is set LOW when the time is elapsed.

## 2 Memories

### 2.1 Local memories (M)

PLUTO has 600 memories free to use in the application program. These memories are local which means that they can only be used in the own Pluto unit. Example: memory M0.10 can only be set and read in the application program in Pluto unit no: 0.

The memories are addressed as shown below:

Pluto family:	Program syntax:
All models except Pluto AS-i	M_.0 – M_.599
Pluto AS-i	M_.0 – M_.149
<i>Pluto AS-i instruction set 3</i>	<i>M_.0 – M_.599</i>

Example:

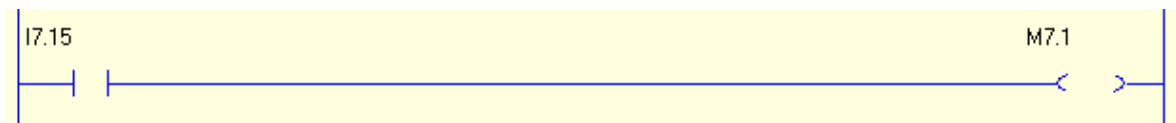

Equivalent text form:  $M7.1 = I7.15$

**Function:** Memory M7.1 is HIGH (1) when input I7.15 is HIGH.

**NOTE:** Although work memory-cells are local within one PLUTO PLC, identity of the PLUTO-unit must be set as shown above.

### 2.2 Global memories (GM)

Global memories can be used in the same way as local memories but with the difference that they are transmitted on the bus and can be read by other Pluto units and used in their application programs as input condition.

One example for use of the global memories is to make it possible to have a memory which is the summary of a complex program function. Instead of making the same complex program function in many Pluto:s it can be programmed in just one unit and the result can be stored in a global memory which can be read by all Pluto:s on the bus.

The global memories are addressed as shown below:

Pluto type:	Global memory:	Program syntax:
All models except B42 AS-i	0-11	GM_.0 – GM_.11
B42 AS-i	0-27	GM_.0 – GM_.27

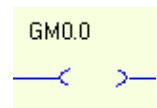

## 2.3 System memories (SM)

A set of system memories with different functions are available in PLUTO.

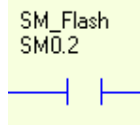

Syntax: SM[unit].[no]

I/O-address:	Symbolic name:	Function:	Type:
SM_.0	SM_StepNew	On at first scan in new sequence step.	R
SM_.1	SM_Ditto	Result of last logic operation.	R
SM_.2	SM_Flash	Flash: 0.4 / 0.6 sek. (on/off)	R
SM_.3	SM_1Hz	Pulse 1 Hz	R
SM_.4	SM_10Hz	Pulse 10 Hz	R
SM_.5	SM_FastFlash	Flash: 0.17 / 0,33 sek (on/off)	R
SM_.6	SM_DoubleFlash	Double flash: 0,11 / 0,2 /0,11 / 0,67 sec	R
SM_.9	SM_SysInIt	On at first scan after power on	R
SM_.11	SM_Overflow	Overflow in arithmetic	R
SM_.12	SM_DivByZero	Divide by zero	R
SM_.15**	SM_PlutoB	This is Pluto B processor	R
SM_.39	SM_Button	Button in front panel	R
SM_.84*	SM_PlutoB	This is Pluto B processor	R
SM_.100	SM_Pluto0_Present	Pluto #0 is present	R
:	:	:	:
SM_.131	SM_Pluto31_Present	Pluto #31 is present	R

\*A20 Family only.

\*\*B46, D45, AS-i and B42 AS-i only.

(Type: R = Read, W = Write)

Example:

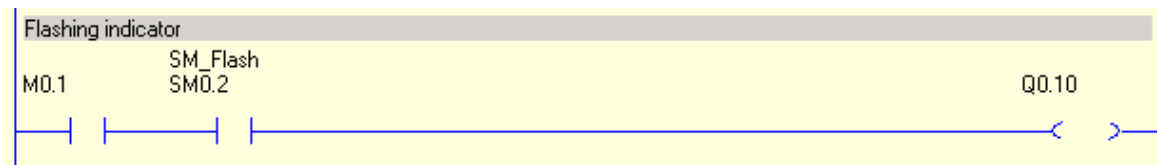

Equivalent text form:  $Q0.10 = M0.1 * SM0.2$  ; Flashing indicator

**Function:** System memory SM0.2 is flashing with an on/off rate of 0.4/0.6 seconds. If M0.1 is set, output Q0.10 flashes with the same rate as SM0.2.

### 3 Sequences

PLUTO has 9 sequence registers with 254 steps each available for use. The sequences operate in parallel and independent of each other.

In a sequence only the code in one step is executed. The transition from one step to another is conditional via jump-instructions. The result of the previous step is reset when the next step is entered. By start up of the system, sequence step 0 is automatically executed which means that a sequence must contain step 0.

#### 3.1 Addressing

A sequence step starts with an instruction as below declaring sequence number and step number.

Sequence/Step:	Program syntax:
1-9/0-254	$Sn.1_{00} - Sn.9_{254}$ ( $n=Pluto$ unit no.)

The program syntax in text form is interpreted as follows:

- The first letter concerns sequence register (S).
- The first number sets the identity of the PLUTO-unit where sequence register is to be addressed.
- The second number (placed after dot-symbol) sets sequence register to be addressed.
- The third number (placed after underscore) sets sequence step to be addressed.

Example:

S0.1\_22            Ū            Start of step 22 in sequence 1 on PLUTO no: 0.

Sequence programming in Pluto Manager:

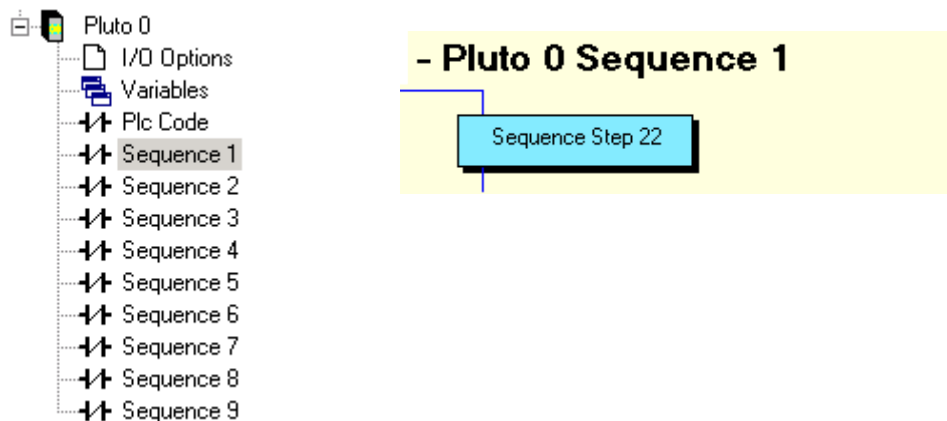

### 3.2 Jump

The jump instructions are used in sequences in order to jump from one step to another. Jump between sequences steps within a sequence can be performed either absolute or relative to the current active step.

Jump function:	Syntax in text form:	Ladder symbol:
Absolute: to step 1	J(01)	01 —< J >—
Relative: one step forward	J(+1)	+1 —< J >—
Relative: one step backward	J(-1)	-1 —< J >—

The jump can be either condition or unconditional.

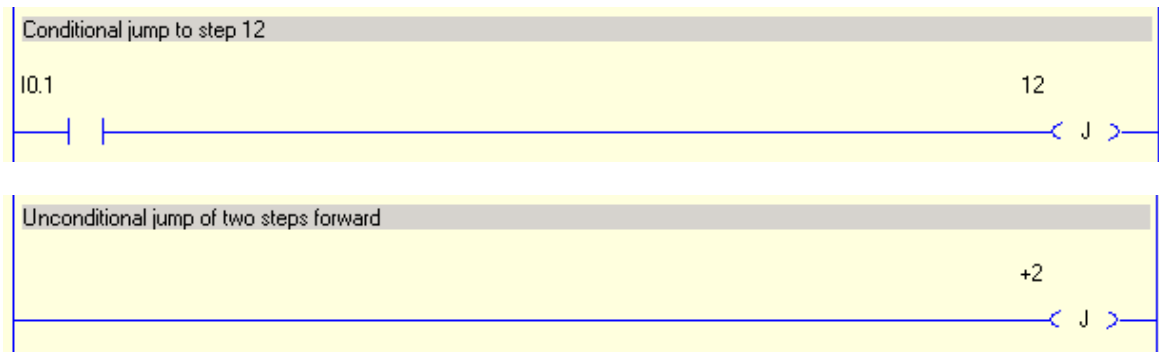

#### Example of a sequence in text form:

S0.1_00	Ū	Pluto 0, sequence 1, step 0:
Q0.1 = I0.2		Q0.1 is operated by I0.2
J(+1) = Q0.10*M0.7		Jump to the next step (step 1) when output Q0.10 and M0.7 is HIGH.
S0.1_01	Ū	Pluto 0, sequence 1, step 1:
S(Q0.2) = I0.3		Output Q0.2 is set HIGH by I0.3
J(10) = M0.10		Jump to step 10 when M0.10 is HIGH.
S0.1_10	Ū	Pluto 0, sequence 1, step 10:
R(Q0.2) = I0.4		Output Q0.2 is set LOW by I0.3
J(0) = GM0.0		Jump to step 0 when GM0.0 is HIGH.

## The equivalence in ladder

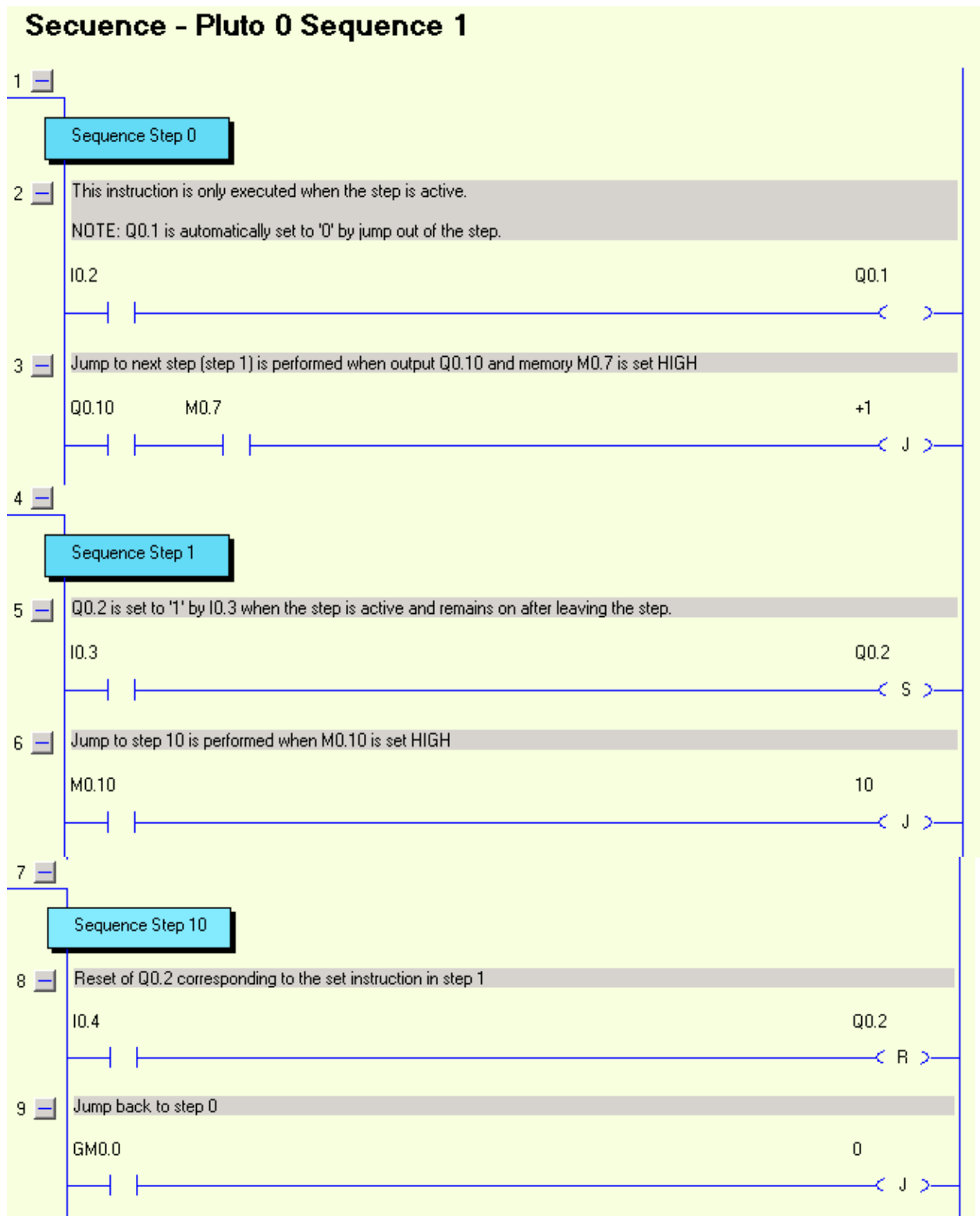

## 4 Numeric operations

### 4.1 Registers

#### 4.1.1 Addressing

PLUTO has 150 16-bit registers where i.e. calculation results can be stored. The registers have the following number range: -32 768 ... +32 767

Register are addressed as shown below:

Register:	Syntax:
0-149	R0.0 – R0.149

With instruction set 3 a new variable type “DR, Double Register” is introduced. A double register consists of the corresponding R register (low word) and the following register (high word). E.g. DR1.4 = R1.5 (high word) and R1.4 (low word). A double register with odd number is not allowed. A double register can handle 32 bit values which corresponds to the following number range: -2147483648 ... +2147483647

Double Register:	Syntax:
0-148*	DR0.0 – DR0.148

\*Only even numbers allowed

#### 4.1.1.1 Half Double Registers

When a double register is used, the two (single) registers which the double register consists of cannot be addressed directly. This is to avoid register/double register conflicts by mistake. If for example DR0.4 is used in a program the registers R0.4 and R0.5 cannot be addressed directly but instead by “DR0.4.Lo” (=R0.4) and “DR0.4.Hi” (=R0.5). When the .Lo and .Hi syntax is used the compiler is informed that the programmer really intends to access half of a double register.

Double Registers		R0.1	
Variable	Symbolic Name	R0.2	
DR0.0 (R0.0 : R0.1)		R0.3	
DR0.2 (R0.2 : R0.3)		R0.4	Example.Lo
DR0.4 (R0.4 : R0.5)	Example	R0.5	Example.Hi

The double register DR0.4 “Example” consists of R0.4 and R0.5. These halves of “Example” shall be addressed as “Example.Lo” and “Example.Hi”.



## 4.1.2 Operations

### Assignment of register (with Instruction set 2)

Operation:	Syntax for Registers:
Increment by 1	(R0.100++)
Decrement by 1	(R0.100--)
Add constant	(R0.100 += 77)
Subtract constant	(R0.100 -= 77)
Assign with absolute value = 1	(R0.100 = 1)
Addition with other register (R0.100 = R0.100 + R0.102)	(R0.100 += R0.102)
Subtract with other register (R0.100 = R0.100 - R0.102)	(R0.100 -= R0.102)
Assign with other reg. value	(R0.100 = R0.102)

### Assignment of register (with instruction set 3)

Operation:	Syntax for Registers:	Syntax for Double Registers:
Increment by 1	(R0.100++)	(DR0.100++)
Decrement by 1	(R0.100--)	(DR0.100--)
Add constant	(R0.100 += 77)	(DR0.100 += 77)
Subtract constant	(R0.100 -= 77)	(DR0.100 -= 77)
Assign with absolute value = 1	(R0.100 = 1)	(DR0.100 = 1)
Assign with other reg. value	(R0.100 = R0.102)	(DR0.100 = DR0.102)
Multiply with constant	(R0.100 *= 2)	(DR0.100 *= 2)
Divide by constant	(R0.100 /= 2)	(DR0.100 /= 2) (OS ≥ 3.6)
<b>Operation:</b>		
Addition with other register (R0.100 = R0.100 + R0.102)	(R0.100 += R0.102) or (R0.100=R0.100+R0.102)	(DR0.100 += DR0.102) or (DR0.100=DR0.100+DR0.102)
Addition with other register (and store the result in a third register) (R0.100 = R0.102 + R0.104)	(R0.100=R0.102+R0.104)	(DR0.100=DR0.102+DR0.104)
<b>Operation:</b>		
Subtract with other register (R0.100 = R0.100 – R0.102)	(R0.100 -= R0.102) or (R0.100=R0.100-R0.102)	(DR0.100 -= DR0.102) or (DR0.100=DR0.100-DR0.102)
Subtract with other register (and store the result in a third register) (R0.100 = R0.102 – R0.104)	(R0.100=R0.102-R0.104)	(DR0.100=DR0.102-DR0.104)
<b>Operation:</b>		
Multiply with other register (R0.100 = R0.100 * R0.102)	(R0.100 *= R0.102) or (R0.100=R0.100*R0.102)	(DR0.100 *= DR0.102) or (DR0.100=DR0.100*DR0.102)
Multiply with other register (and store the result in a third register) (R0.100 = R0.102 * R0.104)	(R0.100=R0.102*R0.104)	(DR0.100=DR0.102*DR0.104)
<b>Operation:</b>		
Divide by other register (R0.100 = R0.100 / R0.102)	(R0.100 /= R0.102) or (R0.100=R0.100/R0.102)	(DR0.100 /= DR0.102) or (DR0.100=DR0.100/DR0.102) (OS ≥ 3.6)
Divide by other register (and store the result in a third register) (R0.100 = R0.102 / R0.104)	(R0.100=R0.102/R0.104)	(DR0.100=DR0.102/DR0.104) (OS ≥ 3.6)
<b>NOTE:</b> It is possible to “mix” R and DR in assignments		Ex: (DR0.100 *= R0.102)

At division with zero SM\_DivByZero (SM\_.12) is set, and the result is set to zero.

If an overflow occurs SM\_Overflow (SM\_.11) is set, and the result is set to either 32767 or -32768 depending on the sign of the overflow (for DR: 2147483647 or -2147483647).

SR\_Remain (SR\_.2) contains the remainder after division.

Example:

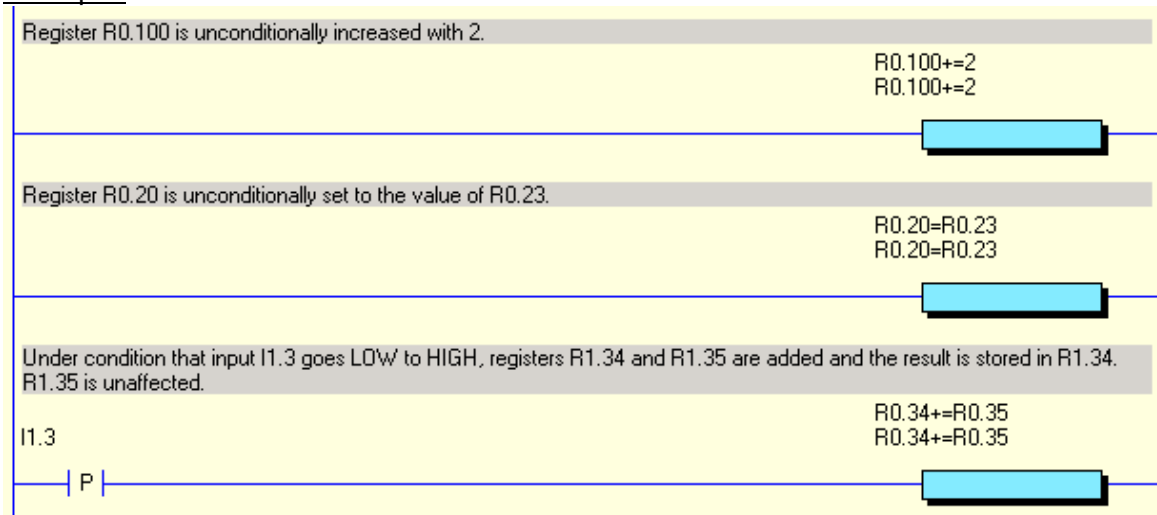

Equivalence in text form:

( R0 . 100 += 2 )  
( R0 . 20 = R0 . 23 )  
( R1 . 34 += R1 . 35 ) = P ( I1 . 3 )

**Function:** At increment of register the increment stops when the register value reaches the limits (32 767 or -32 768)

## Comparison of register

Comparison:	Syntax for Registers:	Syntax for DoubleRegisters:
Equal to (constant)	(R0.100=1)	(DR0.100=1)
Greater than	(R0.100>1)	(DR0.100>1)
Less than	(R0.100<1)	(DR0.100<1)
Greater than or Equal to	(R0.100>=1)	(DR0.100>=1)
Less than or Equal to	(R0.100<=1)	(DR0.100<=1)
Equal (two registers)	(R0.100=R0.101)	(DR0.100=DR0.102)
Greater than	(R0.100>R0.101)	(DR0.100>DR0.102)
Less than	(R0.100< R0.101)	(DR0.100< DR0.102)
Greater than or Equal to	(R0.100>= R0.101)	(DR0.100>= DR0.102)
Less than or Equal to	(R0.100<= R0.101)	(DR0.100<= DR0.102)

### Example:

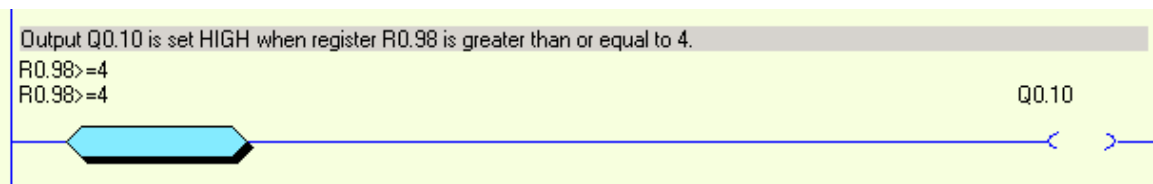

In text form:  $Q0.10 = (R0.98 \geq 4)$

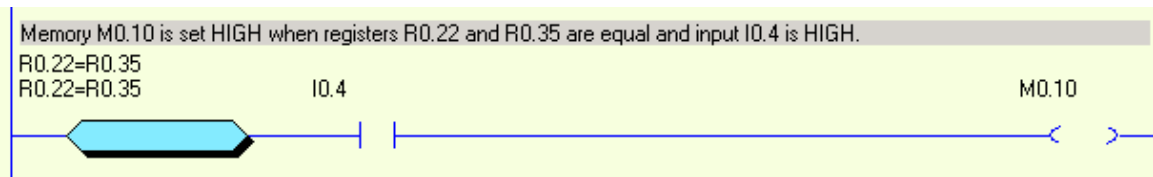

In text form:  $M0.10 = (R0.22 = R0.35) * I0.4$

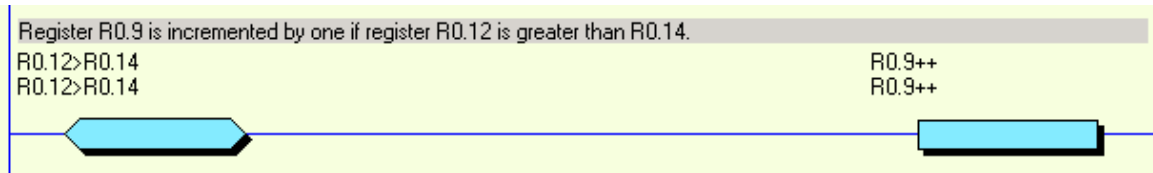

In text form:  $(R0.9++) = (R0.12 > R0.14)$

### 4.1.3 System registers

PLUTO has a set of system registers with different functions.

System registers

Syntax: SR[*unit*].[*no*]

I/O-address:	Symbolic name:	Function:	Type:
For all Pluto models:			
SR_.2	SR_Remain	Remain part after division	R
SR_.8*	SR_ExecFreeTime	PLC cycle time left to be used (ms)	R
SR_.9	SR_ExecTime	PLC execution time in ms	R
SR_.10	SR_PlutoDisplay	Pluto display figure. For user error: 200+no	W
SR_.11	SR_ErrorCode	Error code	R
SR_.12	SR_ErrorLog1	Last error code	R
SR_.13	SR_ErrorLog2	2:nd last error code	R
SR_.14	SR_ErrorLog3	3:rd last error code	R
SR_.40	SR_SupplVolt	Supply voltage (x10 Volt)	R

A20, B20; D20, S20, B22:			
SR_.41	SR_I5_Volt	Voltage analogue input I5 (x10 volt)	R
SR_.42	SR_Q16_Current	Current (mA) output no.Q16 (only Pluto A20)	R
SR_.43	SR_Q17_Current	Current (mA) output no.Q17 (only Pluto A20)	R

B46, S46, D45:			
SR_.41	SR_I5_Volt	Voltage at analogue input I5 (x10 volt)	R
SR_.45	SR_I6_Volt	Voltage at analogue input I6 (x10 volt)	R
SR_.46	SR_I7_Volt	Voltage at analogue input I7 (x10 volt)	R

Pluto AS-i			
SR_.15**	SR_ASi_Slave_Missing	First AS-i slave missing. B slave encoded as no+32	R
SR_.16**	SR_ASi_Slave_Chanf	First AS-i slave channel fault. B slave encoded as no+32	R
SR_.41	SR_IQ11_Volt	Voltage analogue input IQ11 (x10 volt)	R
SR_.44	SR_IQ10_Volt	Voltage at analogue input IQ10 (x10 volt)	R
SR_.45	SR_IQ12_Volt	Voltage at analogue input IQ12 (x10 volt)	R
SR_.46	SR_IQ13_Volt	Voltage at analogue input IQ13 (x10 volt)	R

B42 AS-i			
SR_.15	SR_ASi_Slave_Missing	First AS-i slave missing. B slave encoded as no+32	R
SR_.16	SR_ASi_Slave_Chanf	First AS-i slave channel fault. B slave encoded as no+32	R
SR_.41	SR_I1_Volt	Voltage at analogue input I1 (x10 volt)	R
SR_.45	SR_I2_Volt	Voltage at analogue input I2 (x10 volt)	R
SR_.46	SR_I3_Volt	Voltage at analogue input I3 (x10 volt)	R

\*OS version 3.0 or later

\*\*OS version 2.10.4 or later

Example:

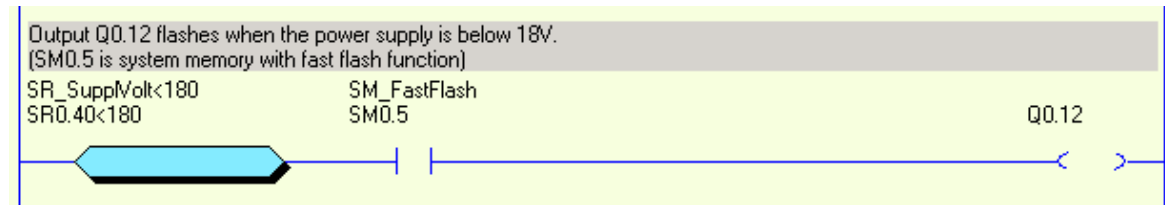

In text form:  $Q0.12 = (SR0.40 < 180) * SM0.5$

## 4.2 Use of analogue values

The analogue values are available by reading the system registers SR40...SR46 (depending on Pluto model, see table below). There are some requirements for the use of these functions.

Analogue inputs:

As illustrated by the table below, some inputs can also be used to measure the voltage at the terminal. In a system register (SR\_) the value can be read in tenths of volts, (240 = 24.0 volt). By use in safety applications a 0-value may not be used as safe condition unless it is used in a dynamically monitored way (the program must monitor that the input value changes). This requirement is because the value in the system register (SR\_) will be set to 0 if an internal fault in the system occurs.

Current monitoring of Q16 and Q17 (only Pluto A20):

The output current from Q16 and Q17 is available in SR42 and SR43, and the value represents mA. The function is intended for monitoring the current in a muting lamp, but other usage is not excluded. As the hardware for measuring the current is not fully redundant the values must be used in a dynamic way. For example if a current to a muting lamp shall be monitored the program must be written so that the change of current by switching the input on and off is observed.

Analogue inputs according to the table below:

	B16, B20, S20, D20, B22, O2:	A20:	B46, S46:	D45:	Pluto AS-i:	B42 AS-i:
SR_40	Supply voltage (x10 V)	Supply voltage (x10 V)	Supply voltage (x10 V)	Supply voltage (x10 V)	Supply voltage (x10 V)	Supply voltage (x10 V)
SR_41	Voltage input I5 (x10 V) (Not Pluto O2)	Voltage input I5 (x10 V)	Voltage input I5 (x10 V)	Voltage input I10 (x10 V)	Voltage input I11 (x10 V)	Voltage input I1 (x10 V)
SR_42	-	Current output Q16	-	-	-	-
SR_43	-	Current output Q17	-	-	-	-
SR_44	-	-	-	-	Voltage input I10 (x10 V)	-
SR_45	-	-	Voltage input I6 (x10 V)	Voltage input I11 (x10 V)	Voltage input I12 (x10 V)	Voltage input I2 (x10 V)
SR_46	-	-	Voltage input I7 (x10 V)	Voltage input I12 (x10 V)	Voltage input I13 (x10 V)	Voltage input I3 (x10 V)

Example:

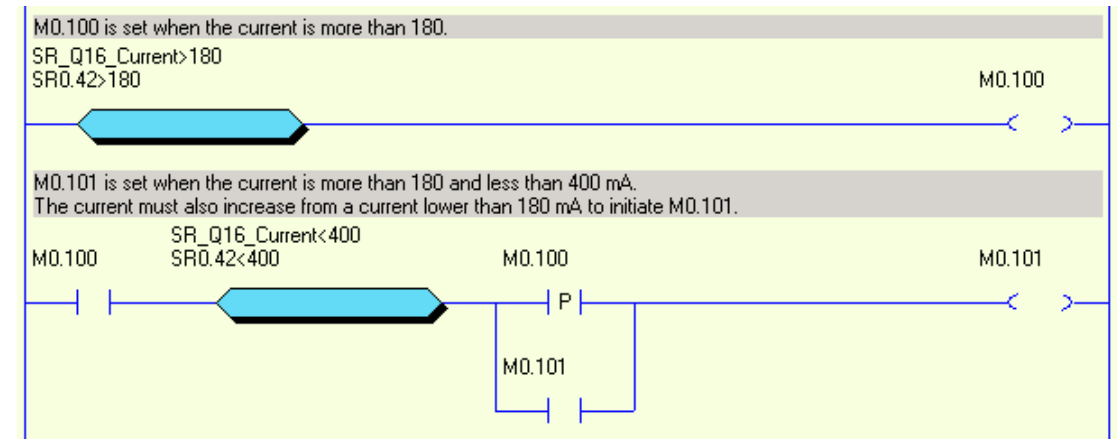

In text form:

$$M0.100 = (SR0.42 > 180)$$
$$M0.101 = M0.100 * (SR0.42 < 400) * (P(M0.100) + M0.101)$$



## 5 Program declaration in text form

In the beginning of the program file different declarations are made. These declarations describe the hardware environment for the Pluto unit.

For more information about the function of the different hardware options see the 'Operating instructions, Hardware'

### 5.1 Identity, station number and Pluto family

Each unit must have a station number 0-31.

It is also possible to connect an external identifier circuit containing a unique 12 figure hexadecimal number. Then it is also necessary to declare the Pluto family.

These two settings are declared as:

! id\_pluto:[*stn.number*]=[*identifier number*] for Pluto A20 family.

! id\_pluto\_Double:[*stn.number*]=[*identifier number*] for Pluto double family.

! id\_pluto\_ASi:[*stn.number*]=[*identifier number*] for Pluto AS-i

! id\_pluto\_B42\_ASi:[*stn.number*]=[*identifier number*] for Pluto B42 AS-i

If identifier is not connected the system will accept this if the identifier number is declared as 000000000000 (12 zero).

Example:

! id_pluto:00=ffff00007FA3	Û	The Pluto-unit is given station number 0 and an identifier with number ffff00007FA3 must be connected to the unit.
! id_pluto:23=000000000000	Û	The Pluto-unit is given station number 23 and the unit shall run without identifier.

### 5.2 Declaration of program code

Since it is possible to have program code for several units stored in one unit it must be declared to which Pluto unit a code part belongs to.

Syntax:

! pgm\_pluto:[*station no.*]

### 5.3 Declaration of I/O

All inputs and the non failsafe outputs (A20: Q10...17, B46 and B42 AS-i: Q10...27, Pluto AS-i: Q10...13) must be declared since they can be used in different ways. The tables below show the options.

#### Inputs

Syntax: ! I[no],[pulse type],[switch 1],[switch 2]

Example: ! I0.5,c\_pulse,non\_inv,no\_filt

Inputs:	Pulse types: (Dynamic sign.)	Switch 1: (optional)	Switch 2: (optional)
I_.0 - I_.17	a_pulse b_pulse c_pulse	non_inv	no_filt
I_.0 - I_.17	static*)		no_filt

\*) I\_.10-I\_.17,**static** does not fulfil cat. 4 according to EN954-1, as stand-alone input

#### Dynamic outputs

Syntax: ! Q[no],[pulse type]

Example: ! Q0.10,a\_pulse

Outputs:	Pulse types:
Q_.10 – Q_.17	a_pulse, b_pulse, c_pulse

#### Non failsafe-outputs Syntax: ! Q[no],static

Example: ! Q0.10,static

Outputs:	Pulse types:
Q_.10 – Q_.17	static

#### Special function, Illuminated push button

Syntax: ! IQ[no],[pulse type]

Example: ! IQ0.12,a\_pulse

In/outputs:	Pulse types:
Q_.10 – Q_.17	a_pulse, b_pulse, c_pulse

#### Example:

! i0.1,a\_pulse ; Input is supplied with dynamic A signal via inverter.

! i0.2,a\_pulse,non\_inv ; Input is supplied with dynamic A signal.

! i0.3,static ; Input is supplied with +24V.

! q0.10,a\_pulse ; Output generates dynamic A signal for supply of inputs.

! q0.11,static ; Input is supplied with dynamic A signal.

## 5.4 Symbolic names

The variables can also be named with a symbolic name which can make a program easier to understand. In Pluto Manager it is declared on a separate page, see Pluto Manager manual.

By programming in text form it is declared. Where in the code the declaration is made depends on whether it is a global or local variable. Global variables I\_., Q\_.0...4 and GM\_.0..11 are declared before the program code for the first Pluto since the variable can be used in all Pluto:s. Local variables are named in the beginning of the program code for the corresponding Pluto, after the I/O declarations. See example.

### Example:

```
! I0.0=MuteSensor1           ; Symbolic names global variables
! Q0.1=MuteSensor2
! GM0.1=MuteSensor2

! Q0.14=IndReset            ; Symbolic names local variables
! M0.0=MutingActive
! R0.0=Counter1
```

## 6 Program example in text form

This program example is the program for the installation example showed in “Operating instruction, Hardware”.

\$name Example, manual

```
! id_pluto:00=000034AD4AE1

! pgm_pluto:00

! q0.10,a_pulse           ; Dynamic output A

! i0.00,static            ; Muting sensor 1
! i0.01,a_pulse,non_inv   ; Muting sensor 2
! i0.02,a_pulse,non_inv   ; Test Contactors
! i0.12,a_pulse           ; Emergency stop PB
! i0.13,a_pulse           ; JSL Lightbeam
! iq0.14,a_pulse          ; Reset with indicator

.*****
,

s0.0_0                    ; Main sequence start

q0.2 = i0.12 * (i0.13 + m0.0) * ( (p(i0.14) * i0.02) + q0.2)
q0.3 = q0.2
                                ; All safety outputs active when Emergency stop(I0.12)
                                ; and JSL(I.13) or muting(M0.0) are active.
                                ; Reset(I0.14) and Test(I0.02) are also needed in the
                                ; start condition.

q0.14 = /q0.2                ; Reset indication active when outputs not active

.*****
,

s0.1_0                    ; Muting Sequence
j(+1)=/i0.00*/i0.01*(SR0.43<100) ; Start condition: both sensors not active

s0.1_1
q0.17 = i0.00 * i0.01 * i0.13
j(+1) = q0.17 * (SR0.43<100) ; Muting start when both sensors and JSL active
s0.1_2
m0.0                      ; M0.0, Memory muting active
q0.17                    ; Indicator muting active
j(0) = /i0.00 + /i0.01   ; Muting stopped by either sensor not active
```

## 7 Appendix A, Compatibility for Pluto

Some of the features described in this manual do not apply to earlier versions of Pluto. Below is an overview of which hardware version and OS version that supports the functionality in question. (Pluto models not in the table do not support the functionality.)

Functionality	Pluto type	Hardware version	OS version
Instruction set 3	A20 v2	All	All
	B20 v2	All	All
	S20 v2	All	All
	B22	All	All
	D20	All	All
	B46 v2	All	≥3.0
	S46 v2	All	≥3.0
	D45	All	All
	AS-i v2	All	≥3.0
	B42 AS-i	All	All
O2	All	All	
Remanent variables	A20 v2	All	All
	B20 v2	All	All
	S20 v2	All	All
	B22	All	All
	D20	All	All
	B46 v2	HW ≥ 2.11	≥3.0
	S46 v2	HW ≥ 2.11	≥3.0
	D45	All	All
	AS-i v2	HW ≥ 3.7	≥3.0
B42 AS-i	All	All	
"Export" variables	All Pluto with instruction set 3	See instruction set 3	≥3.2
Disabling of test pulses Q2, Q3	A20 v2	All	All
	B20 v2	All	All
	S20 v2	All	All
	B22	All	All
	D20	All	All
Read IDFIX number from Pluto	All	All	≥3.4
StatusBus	All Pluto with instruction set 3	All	≥3.6

## Contact information

### Australia

ABB Australia Pty Limited  
Low Voltage Products  
Tel: +61 (0)1300 660 299  
Fax: +61 (0)1300 853 138  
Mob: +61 (0)401 714 392  
E-mail: [kenneth.robertson@au.abb.com](mailto:kenneth.robertson@au.abb.com)  
Web: [www.abbaustralia.com.au](http://www.abbaustralia.com.au)

### Austria

ABB AB, Jokab Safety  
Tel: +43 (0)1 601 09-6204  
Fax: +43 (0)1 601 09-8600  
E-mail: [aleksander.gauza@at.abb.com](mailto:aleksander.gauza@at.abb.com)  
Web: [www.abb.at](http://www.abb.at)

### Belgium

ABB N.V.  
Tel: +32 27186884  
Fax: +32 27186831  
E-mail: [tech.lp@be.abb.com](mailto:tech.lp@be.abb.com)

### Brazil

ABB Ltda  
Produtos de Baixa Tensão  
ABB Atende: 0800 014 9111  
Fax: +55 11 3688-9977  
Web: [www.abb.com.br](http://www.abb.com.br)

### Canada

ABB Inc.  
Tel: +1 514 420 3100 Ext 3269  
Fax: +1 514 420 3137  
Mobile: +1 514 247 4025  
E-mail: [alan.m.brown@ca.abb.com](mailto:alan.m.brown@ca.abb.com)  
Web: [www.abb.com](http://www.abb.com)

### China

ABB (China) Limited  
Tel: 86-21-23287948  
Telefax: 86-21-23288558  
Mobile: 86-186 2182 1159  
E-mail: [harry-yarong.zhang@cn.abb.com](mailto:harry-yarong.zhang@cn.abb.com)

### Czech Republic

ABB AB, Jokab Safety  
Tel: +420 543 145 482  
Fax: +420 543 243 489  
E-mail: [premysl.broz@cz.abb.com](mailto:premysl.broz@cz.abb.com)  
Web: [www.abb.cz](http://www.abb.cz)

### Denmark

JOKAB SAFETY DK A/S  
Tel: +45 44 34 14 54  
Fax: +45 44 99 14 54  
E-mail: [info@jokabsafety.dk](mailto:info@jokabsafety.dk)  
Web: [www.jokabsafety.dk](http://www.jokabsafety.dk)

### ABB A/S

Tel: +45 4450 4450  
Fax: +45 4359 5920  
E-mail: [ordre.komp@dk.abb.com](mailto:ordre.komp@dk.abb.com)  
Web: [www.abb.dk](http://www.abb.dk)

### Finland

ABB Oy  
Web: [www.abb.fi](http://www.abb.fi)

### France

ABB France  
Division Produits Basse Tension  
Tel: 0825 38 63 55  
Fax: 0825 87 09 26  
Web: [www.abb.com](http://www.abb.com)

### Germany

ABB STOTZ-KONTAKT GmbH  
Tel: +49 (0) 7424-95865-0  
Fax: +49 (0) 7424-95865-99  
E-mail: [buero.spaichingen@de.abb.com](mailto:buero.spaichingen@de.abb.com)  
Web: [www.abb.de](http://www.abb.de)

### Greece

ABB SA  
Tel: +30 210.28.91.900  
Fax: +30 210.28.91.999  
E-mail: [dimitris.voulgaris@gr.abb.com](mailto:dimitris.voulgaris@gr.abb.com)  
[nikos.makrakos@gr.abb.com](mailto:nikos.makrakos@gr.abb.com)  
Web: [www.abb.com](http://www.abb.com)

### Ireland

ABB Ltd.  
Tel +353 1 4057 381  
Fax: +353 1 4057 312  
Mobile: +353 86 2532891  
E-mail: [derek.kelly@ie.abb.com](mailto:derek.kelly@ie.abb.com)

### Israel

ABB Technologies Ltd.  
Tel: +972 4 851-9204  
Mobile: +972 52 485-6284  
E-mail: [contact@il.abb.com](mailto:contact@il.abb.com)  
Web: [www.abb.co.il](http://www.abb.co.il)

### Italy

ABB S.p.A.  
Tel. +39 02 2414.1  
Fax +39 02 2414.2330  
Web: [www.abb.it](http://www.abb.it)

### Korea

ABB KOREA  
Low-voltage Product  
Tel: +82 2 528 3177  
Fax: +82 2 528 2350  
Web: [www.jokabsafety.co.kr](http://www.jokabsafety.co.kr)

### Malaysia

ABB Malaysia  
Tel: +60356284888 4282  
E-mail: [chang-sheng.saw@my.abb.com](mailto:chang-sheng.saw@my.abb.com)

### Netherlands

ABB b.v.  
Tel: +31 (0) 10 - 4078 947  
Fax: +31 (0) 10 - 4078 090  
E-mail: [info.lowvoltageproducts@nl.abb.com](mailto:info.lowvoltageproducts@nl.abb.com)  
Web: [www.abb.nl](http://www.abb.nl)

### Norway

ABB AS  
Tel: +47 03500  
Fax: +47 32858021  
Mobile: +47 40918930  
E-mail: [Lars-Erik.Arvesen@no.abb.com](mailto:Lars-Erik.Arvesen@no.abb.com)  
Web: [www.abb.no](http://www.abb.no)

### Poland

ABB Sp. z.o.o  
Tel: +48 728 401 403  
Fax: 22 220 22 23  
E-mail: [adam.rasinski@pl.abb.com](mailto:adam.rasinski@pl.abb.com)  
[safety@pl.abb.com](mailto:safety@pl.abb.com)  
Web: [www.abb.pl](http://www.abb.pl)

### Portugal

Asea Brown Boveri S.A.  
Low Voltage Products - Baixa Tensão  
Tel: +35 214 256 000  
Fax: +35 214 256 390  
Web: [www.abb.es](http://www.abb.es)

### Slovenia

ABB d.o.o.  
Tel: +386 1 2445 455  
Fax: +386 1 2445 490  
E-mail: [aljosa.dobersek@si.abb.com](mailto:aljosa.dobersek@si.abb.com)

### Spain

Asea Brown Boveri S.A.  
Tel: +34 93 4842121  
Fax: +34 93 484 21 90  
Web: [www.abb.es](http://www.abb.es)

### South Africa

ABB  
Tel: +27 10 202 5906  
Fax: +27 11 579 8203  
Mobile: +27 82 500 7990  
E-mail: [Hendrik.Spies@za.abb.com](mailto:Hendrik.Spies@za.abb.com)

### Sweden

ABB AB, Jokab Safety  
Varlabergsvägen 11  
SE-434 39 Kungsbacka  
Tel: +46 21 32 50 00  
Fax: +40 67 15 601  
Mail: [support.jokabsafety@se.abb.com](mailto:support.jokabsafety@se.abb.com)  
Web: [www.abb.com/jokabsafety](http://www.abb.com/jokabsafety)

### Switzerland

ABB Schweiz AG  
Industrie- und Gebäudeautomation  
Tel: +41 58 586 00 00  
Fax: +41 58 586 06 01  
E-mail: [industrieautomation@ch.abb.com](mailto:industrieautomation@ch.abb.com)  
Web: [www.abb.ch](http://www.abb.ch)

### Turkey

ABB Elektrik Sanayi A.Ş.  
Tel: 0216 528 22 00  
Fax: 0216 365 29 44

### United Kingdom

ABB Ltd/JOKAB SAFETY UK  
Tel: +44 (0) 2476 368500  
Fax: +44 (0) 2476 368401  
E-mail: [orders.lvp@gb.abb.com](mailto:orders.lvp@gb.abb.com)  
Web: [www.jokabsafety.com](http://www.jokabsafety.com)

### USA/Mexico

ABB Jokab Safety North America  
Tel: +1 519 735 1055  
Fax: +1 519 7351299  
E-mail: [jokabnaorderentry@us.abb.com](mailto:jokabnaorderentry@us.abb.com)  
Web: [www.jokabsafetyna.com](http://www.jokabsafetyna.com)