



SRX3

High performance ultrasonic fork sensors for transparent label detection

- Dynamic or static teach models
- Slot size 3mm
- High resolution up to 2 mm label gap
- M8 connector with PNP or NPN output
- M12 connector with PNP/NPN output and external teach-in
- Rugged and sturdy aluminium housing



SENSORS

APPLICATIONS

- Detection of transparent, opaque, or metallic ink labels
- Double sheet detection
- Adhesive surface detection



SRX3		
Slot width		3 mm
Slot depth		68 mm
Switching frequency		500 hz
Emission type		Ultrasonic 300 Khz
Setting		300 mm
Power supply	Vdc	12...30 Vdc
Output	PNP	•
	NPN	•
Connection	Connector	M12 5-pin
	Connector	M8 4-pin
Approximate dimensions (mm)		90 x 55 x 22
Housing material		Aluminium
Mechanical protection		IP54

TECHNICAL DATA	
SPECIFICATION	
Minimum pulse time	1ms
Detectable size	> 2mm
Max. tape speed	60m/min
Tape size	> 16mm
Ultrasonic frequency	300 Khz
ELECTRICAL DATA	
Power supply	12...30 Vdc
Current consumption	< 55mA
Ripple	10%
Output current	250 mA max.
Output saturation voltage	< 1,5V @ 100mA
Rising time	0,8 us max
Falling time	1,6 us max
Power On delay	325 ms
Response time	1ms
Switching frequency	500 hz
Output	PNP / NPN
MECHANICAL DATA	
Connection	M12 5 pin
Operating temperature	0 °C ... +50 °C
Storage temperature	-25 °C ... +75 °C
Humidity	35...85% rH non condensing
Vibration	0.5 mm amplitude, 10 ... 55 Hz frequency, for every axis (EN60068-2-6)
Shock resistance	11 ms (30 G) 6 shock for every axis (EN60068-2-27)
Housing material	Aluminium
Protection class	IP54
Weight	300g

DIMENSIONS

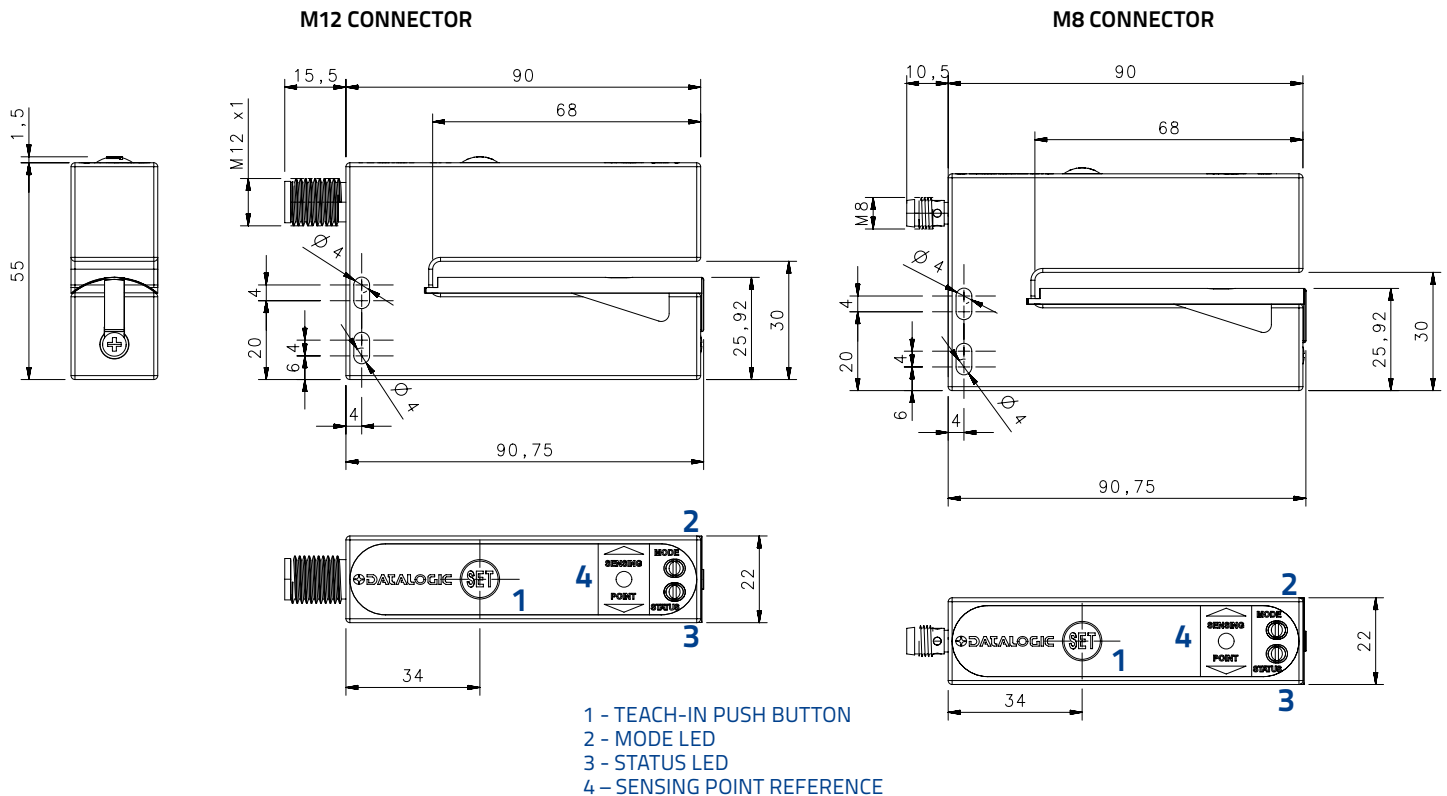

INDICATORS AND SETTINGS

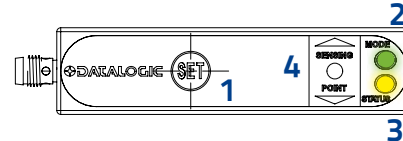
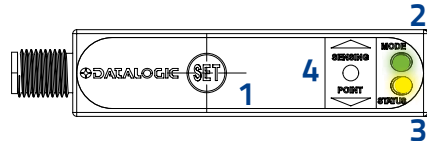

- 1 - TEACH-IN PUSH BUTTON
- 2 - MODE LED
- 3 - STATUS LED (OUTPUT LED)
- 4 - SENSING POINT REFERENCE

CONNECTIONS

M12 CONNECTOR – 5 PIN

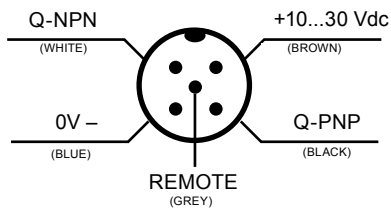

BROWN	1	+10...30 Vdc
WHITE	2	Q-NPN
BLACK	4	Q-PNP
BLUE	3	0 V
GREY	5	TEACH-IN

M8 CONNECTOR – 8 PIN

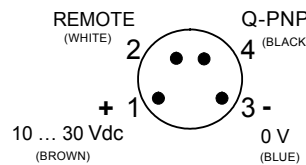

BROWN	1	+10...30 Vdc
WHITE	2	REMOTE
BLACK	4	Q-PNP
BLUE	3	0 V

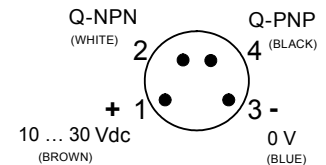

BROWN	1	+10...30 Vdc
WHITE	2	Q-NPN
BLACK	4	Q-PNP
BLUE	3	0 V

MODEL SELECTION AND ORDER INFORMATION

ADJUSTMENT	OUTPUT	CONNECTION	MODEL	ORDER No.
Dynamic Teach-in	PNP/NPN+EXT	M12 5 pin	SRX3-5-US-M12-PNH	953171000
Static Teach-in	PNP/NPN+EXT	M12 5 pin	SRX3-5-US-3-M12-PNH	953171010
Dynamic Teach-in	PNP+EXT	M8 4 pin	SRX3-6-US-M8-PH	953171020
Static Teach-in	PNP+EXT	M8 4 pin	SRX3-6-US-3-M8-PH	953171030
Dynamic Teach-in	PNP/NPN	M8 4 pin	SRX3-6-US-M8-PN	953171040
Static Teach-in	PNP/NPN	M8 4 pin	SRX3-6-US-3-M8-PN	953171050

CABLES

TYPE	No. Of POLES	SHEAT	LENGTH	DESCRIPTION	ORDER No.
Female M12 Connector (Axial)	5-poles	Grey, P.V.C.	3 m	CS-A1-03-G-03	95ACC2110
			5 m	CS-A1-03-G-05	95ACC2120
			10 m	CS-A1-03-G-10	95ACC2140
		Black, P.V.C. UL	3	CS-A1-03-U-03	95ASE1170
			5	CS-A1-03-U-05	95ASE1180
			10	CS-A1-03-U-10	95ASE1190
M8 Connector (Axial)	4-poles	Grey, P.V.C.	3 m	CS-B-1-02-G-03	95A251420
			5 m	CS-B-1-02-G-05	95A251430
			7 m	CS-B-1-02-G-07	95A251440
			10 m	CS-B-1-02-G-10	95A251480
		P.U.R.	2 m	CS-B-1-02-R-02	95A251500
			5 m	CS-B-1-02-R-05	95A251520
M8 Connector (radial 90°)	4-poles	Grey, P.V.C.	3 m	CS-B2-02-G-03	95A251450
			5 m	CS-B2-02-G-05	95A251480
			7 m	CS-B2-02-G-07	95A251470
		P.U.R.	5 m	CS-B2-02-R-05	95ACC2110